

QMB139 (GY6)

4-Stroke OHV Engine & Transmission

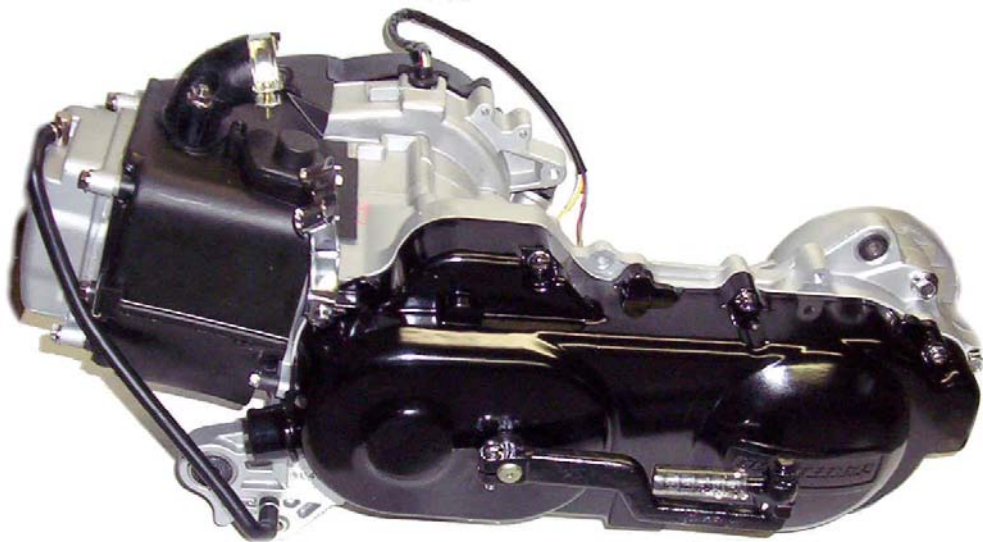

Service and Maintenance Manual

Contents

General Information

Technical Tips	1
Torque Settings	8
Lubrication Requirements	9
Trouble Shooting	12

Scheduled Maintenance

Fuel Filter & Throttle	17
Air Filter & Spark Plug	18
Valve Adjustment	19
Ignition Timing	20
Gear Oil	21

Lubricating System

Engine Requirements	23
Oil Change	24
Oil Pump Removal	25
Oil Pump Assembly	27

Fuel System

General Information	30
Troubleshooting	31
Carburettor	32

Cylinder Head & Valves

Overview	43
Cylinder Head Disassembly	46
Valve Removal / Inspection	50
Cylinder Head Assembly	55

Cylinder & Piston

General Information	59
Cylinder Removal	61
Piston Removal & Inspection	62
Reassembly	64

Drive Pulley & Clutch

General Information	67
Drive Belt Cover Removal	69
Drive Belt Replacement	72
Drive Pulley Removal	73
Roller Weights	74
Clutch Assembly	76

Transmission

General Information	81
Transmission Disassembly	83
Bearing Replacement	84
Transmission Assembly	85

Crankcase & Crankshaft

General Information	87
Crankcase Disassembly	89
Crankshaft Removal & Inspection	91
Crankcase Assembly	92

Charging System

Circuit Diagram	94
Overview	95
Charging System	99
Voltage Rectifier	100
Magneto	101

Ignition

Circuit Diagram	106
General Information	107
CDI (Capacitor Discharge Ignition)	109
Ignition Coil	110
Magneto Pickup Coil	111

Starter System

Circuit Diagram	112
Starter Motor Removal & Inspection	114

1. General Information

Technical Tips

- Replace all gaskets, o-rings, circlips and cotter pins when performing maintenance on the scooter. Nuts and bolts on all engine covers should be tightened in a diagonal pattern to uniformly distribute clamp force.

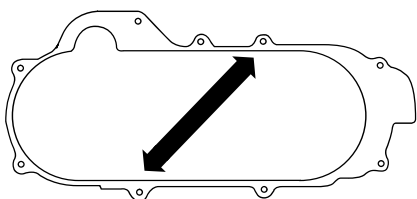
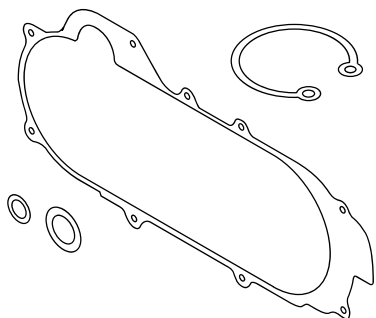

- Use lubricants recommended in this manual at all times to assure peak performance from the scooter.



- Use only genuine replacement parts when performing repairs to the scooter.

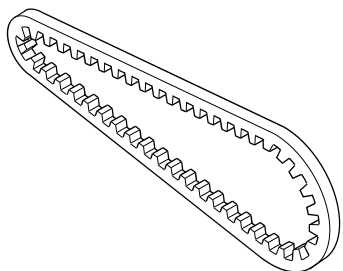

- Special service tools may be required to perform maintenance and repairs on this scooter. Always use the proper tools to prevent damage to the scooter.

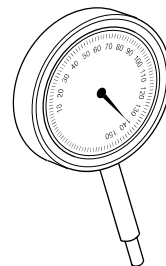

- Clean and lubricate all engine parts during the disassembly and reassembly process to prevent damage to the engine.

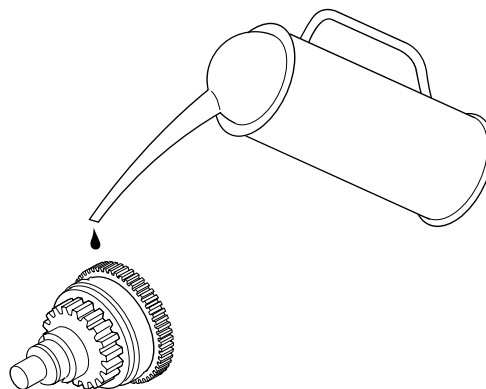

1. General Information

Technical Tips (continued)

•When performing maintenance on the scooter, make sure that all moving parts and controls move freely and return to their proper position.

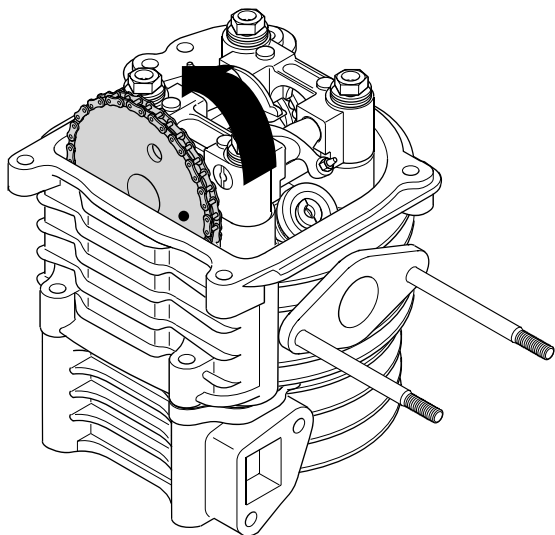

•When disconnecting the battery, always disconnect the negative terminal first.

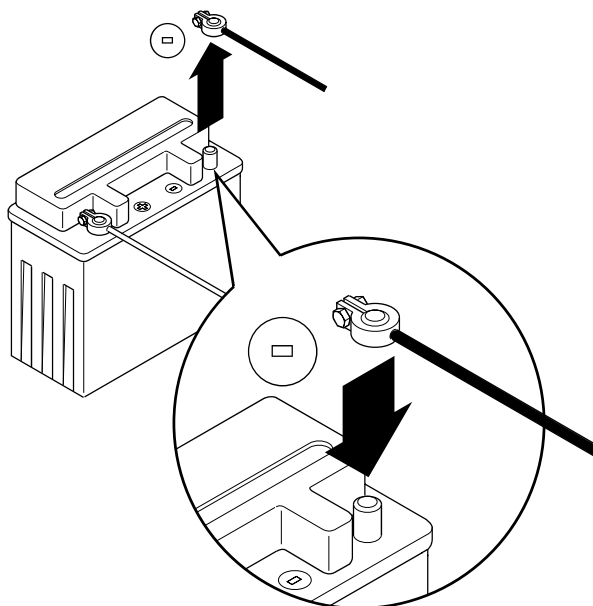

•When connecting the battery, always connect the positive terminal first.

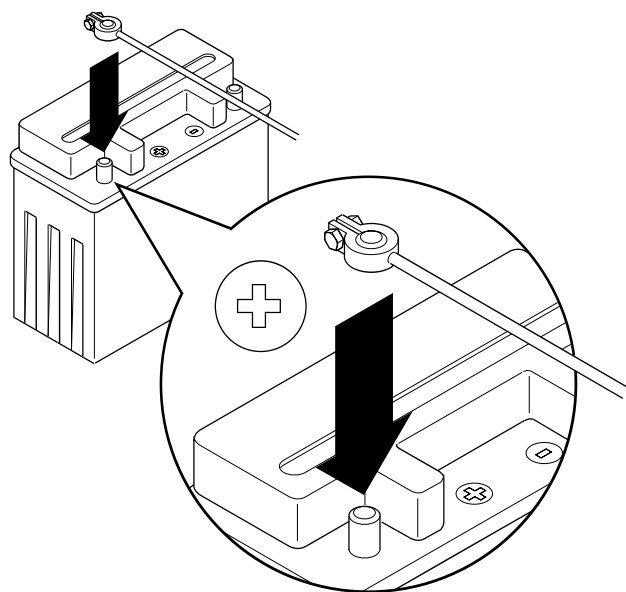

•Make sure that tools and service equipment do not come in contact with both battery terminals.

•Cover both battery terminals with a light coat of grease to prevent corrosion.

1. General Information

Technical Tips (continued)

- When replacing fuses, always use an exact replacement. Do not use fuses of a higher amp rating!

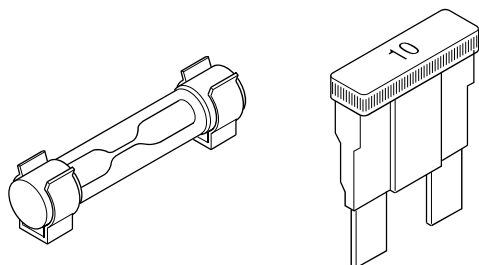

- When assembling wire connectors, press firmly to assure the lock tab fully engages.

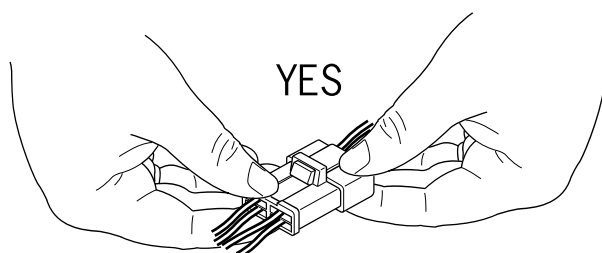

- Replace all rubber caps on wire connectors after performing maintenance.

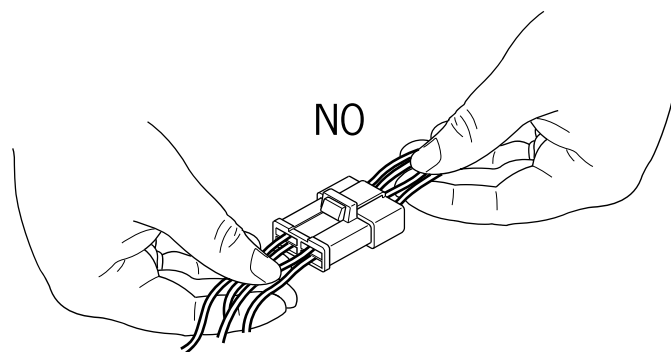
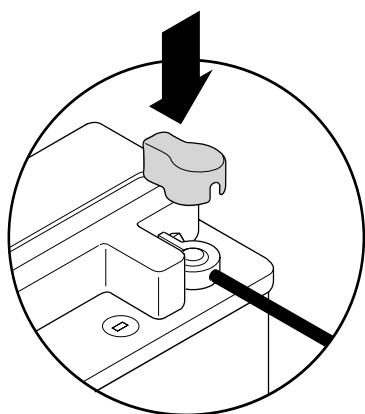

- When disconnecting wire connectors, press firmly on the locking tab and pull the body of the connectors. Never pull on the wires

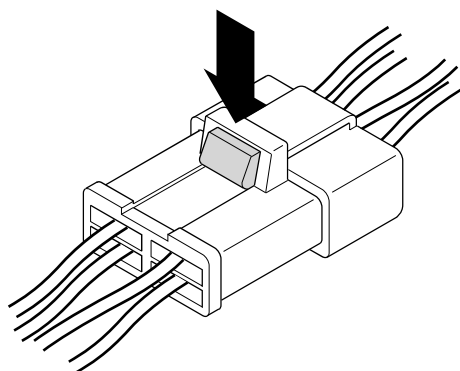

- Make sure that all wire terminals are properly in place before attempting to assemble any wire connector.

1. General Information

Technical Tips (continued)

- Make sure that all wiring connectors are fully seated and lock tabs engaged.

- Check if almuce of connector is covered and fixation is tight.

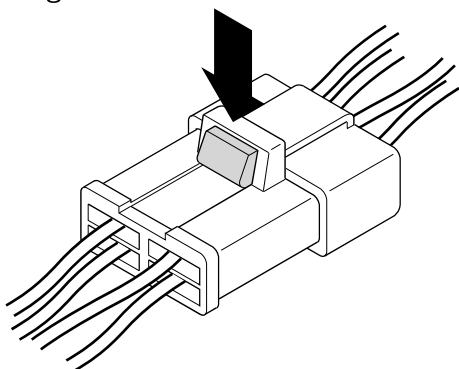

- Make sure that all protective covers are properly in place over the wiring connectors.

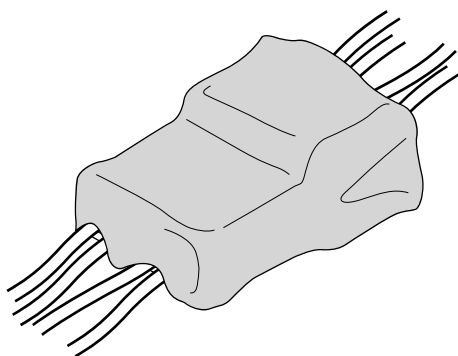

- Never reuse damaged wire terminals or connectors.

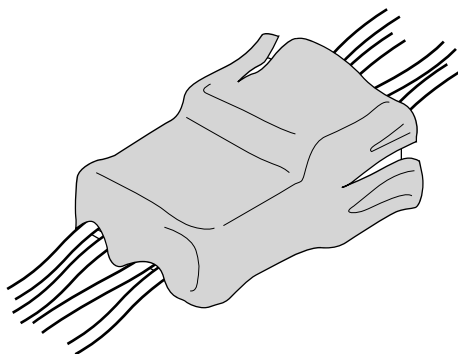

- Never reuse damaged wire terminals or connectors.

- Replace all rubber covers on wire connectors to prevent water from getting into the connector.

- Strip of main wire must be fixed on assigned position.

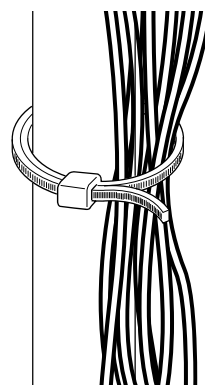

- Insulator of aluminum strip must be affixed to wires.

- Make sure that all wiring harness retainers are properly placed.

- Do not over tighten wiring ties to prevent pinching of wires.

- Do not allow wiring harness to hang in loose loops.

1. General Information

Technical Tips (continued)

•Make sure that all wire clips are properly attached.

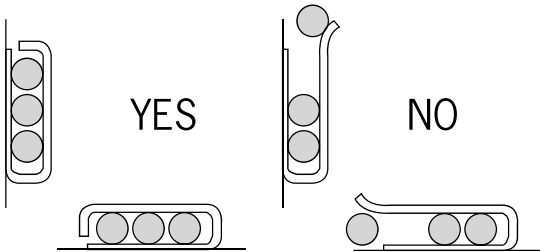

•Make sure that the wiring harness and all wires do not contact moving or rotating parts of the scooter.

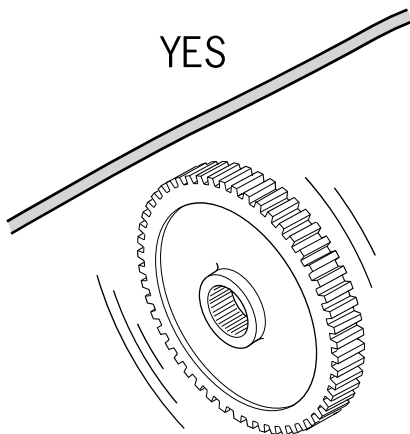
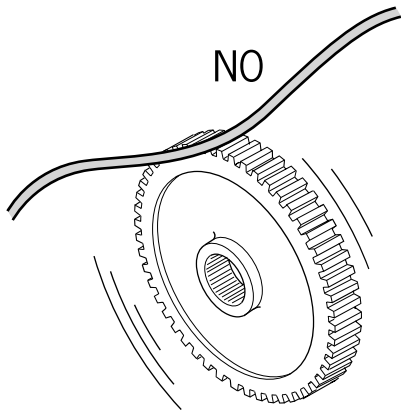

•Make sure that the wiring harness and all wires do not contact hot components or surface parts of the scooter.

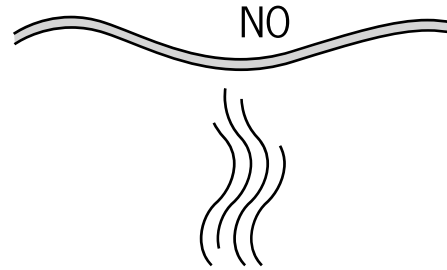

•Make sure that the wiring harness and all wires do not contact sharp edges or parts of the scooter. Use tape to prevent damage to wires on sharp edges.

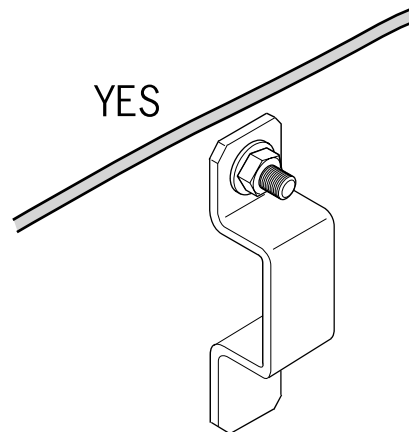
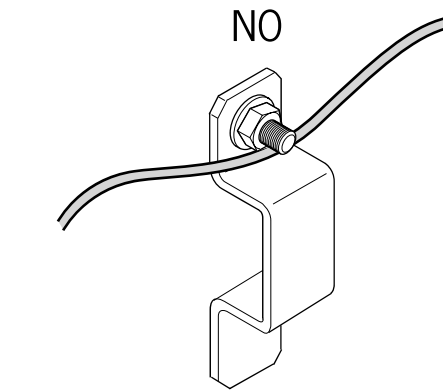

1. General Information

Technical Tips (continued)

- Do not pull wires too tightly.
- Use tape to protect against sharp edges.
- Make sure that all rubber grommets are in place to protect the wiring harness.
- Do not reuse broken or frayed wires.
- Repair or replace wires as necessary.

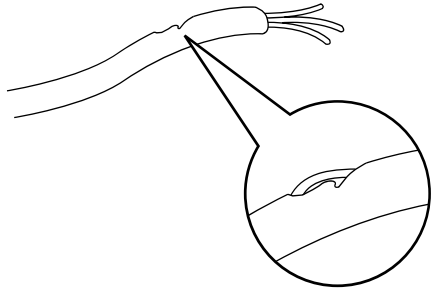

1. General Information

Technical Tips (continued)

Definitions of diagrams

The following icons are used to highlight important operations in the service of the scooter.



Lubricating oil required.



Grease required.

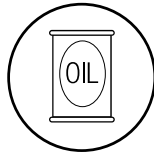

Engine oil required.



Special tools required.

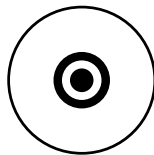

Special attention required.

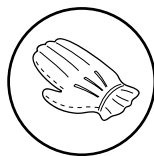

Dangerous and important,
special care required.

1. General Information

Torque Settings

Standard Torque Settings

General Torque Requirements for Standard Fasteners

Fastener Type	Torque	Fastener Type	Torque
5mm Cap Screw	.5 kg/cm	5mm Socket Head Screw	.4 kg/cm
6mm Cap Screw	1 kg/cm	6mm Socket Head Screw	.9 kg/cm
8mm Cap Screw	2.2 kg/cm	8mm Flange Head Screw	1.2 kg/cm
10mm Cap Screw	3.5 kg/cm	10mm Flange Head Screw	2.7 kg/cm
12mm Cap Screw	5.5 kg/cm	12mm Flange Head Screw	4.0 kg/cm

Special Torque Settings

Torque Requirements for Engine Fasteners

Fastener Type	Number Used	Dia. (mm)	Torque kg m (in. lbs)	Comments
Cylinder Bolt A	2	8	.9	
Cylinder Bolt B	2	8	.9	
Oil Filter Screen Cap	1	30	1.5	
Exhaust Pipe Flange Bolt	2	6	.9	
Flange Screw Belt Pulley	4	8	2.0	Lubricate with Engine Oil
Valve Adjusters	2	5	.9	Lubricate with Engine Oil
Cam Chain Adjuster	1	6	1.0	
Guide Plate Screw / Oil Fill Screw	1	8	1.3	
Clutch Cover Screw	1	12	5.5	
Clutch Driven Unit Mounting Screw	1	12	5.5	
Starter Motor Mounting Screw	2	6	1.0	
Oil Pump Mounting Screw	3	6	1.2	
Clutch Driver Mounting Screw	1	12	5.5	
ACG coil Mounting Screw	3	6	1.0	
Cam Chain Adjuster Screw	1	6	.5	
Spark Plug	1	10	1.2	

Torque Requirements for Frame Fasteners

Fastener Type	Number Used	Dia. (mm)	Torque kg m (in. lbs)	Comments
Cylinder Bolt A	1	25.4	8-12	
Cylinder Bolt B	1	10	4-5	
Oil Filter Screen Cap	1	14	8-10	
Exhaust Pipe Flange Bolt	1	10	3-4	
Flange Screw Belt Pulley	1	8	2-3	Use Soft Set Lock-Tite
Valve Adjusters	1	5	.5	

1. General Information

Lubrication Requirements: Engine

Item Location	Recommended Lubricant
valve guide valve stem moving part	SAE 5W 30 Engine Oil
cam shaft lug surface	API-SG Grade Engine Oil
valve rocking arm friction surface	oil
camshaft drive chain	grease
cylinder fixed screw bolts and nuts	oil
around piston and piston ring groove	oil
around piston pin	oil
cylinder surface	oil
connecting rod, piston pin bore	oil
connecting rod big end	oil
crankshaft R, L side oil seal	oil
starter reduction rear engaging (mating) part	
countershaft gear engaging part	oil
final gear engaging part	oil
each bearing rotational part	grease
o-ring surface	oil
oil seal lip	oil
starter idle gear	oil
friction spring moving part, shaft moving part	grease
shaft moving groove part	oil
starter drive axle	grease
AC-generator connector	adhesive

1. General Information

TYPICAL INSTALLATION

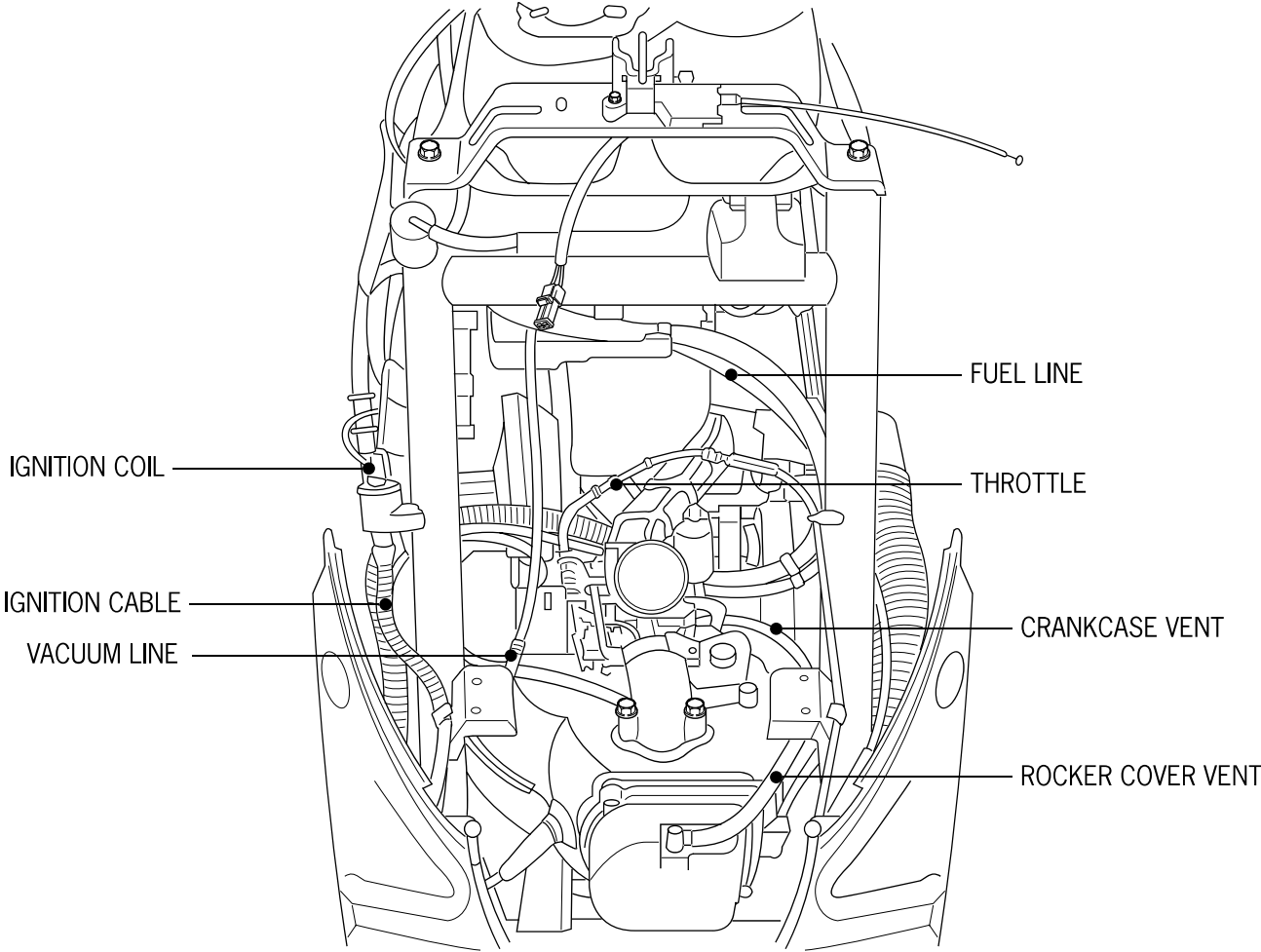

1. General Information

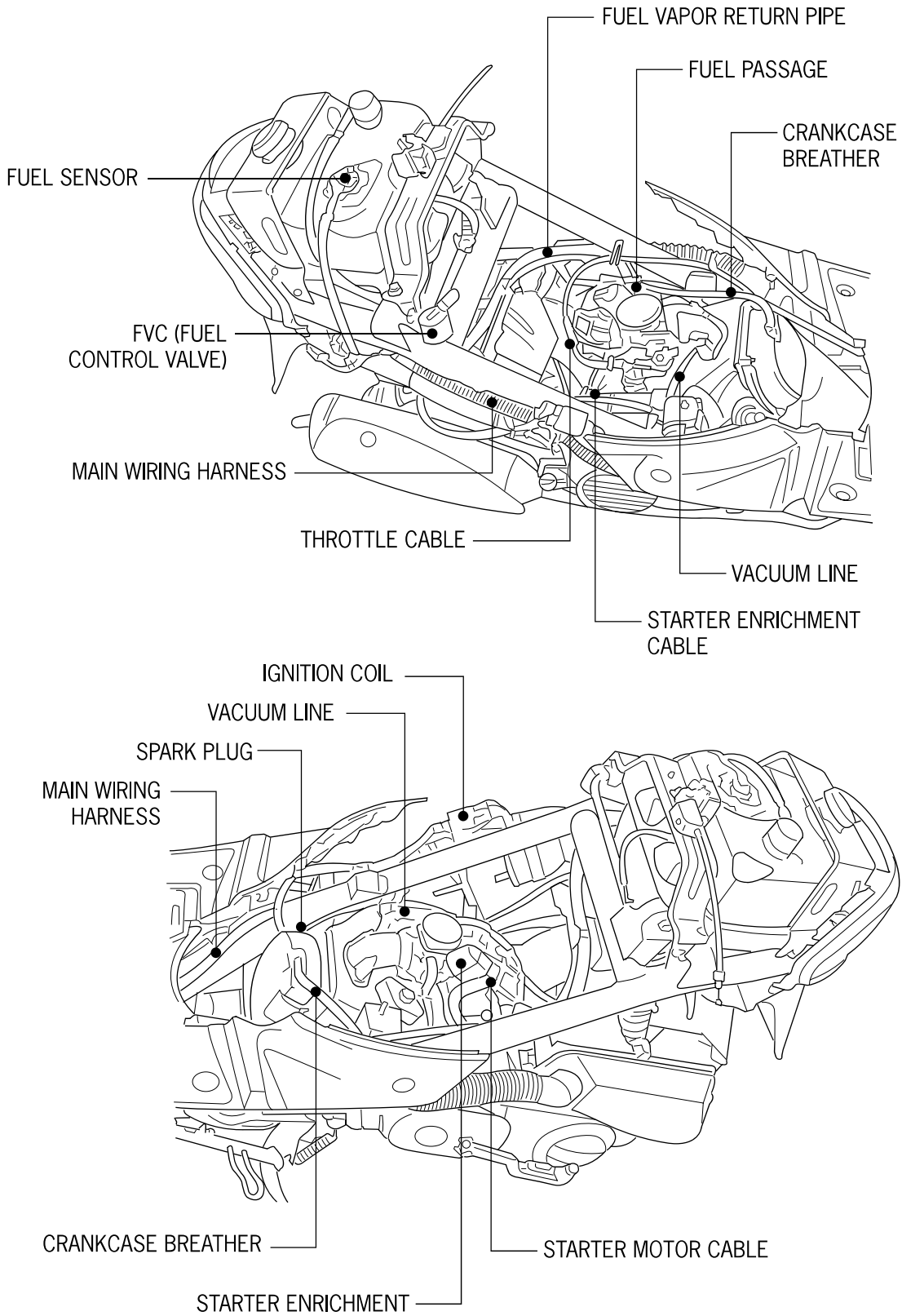

1. General Information

Trouble Shooting Guide Starter Failure or Hard Starting

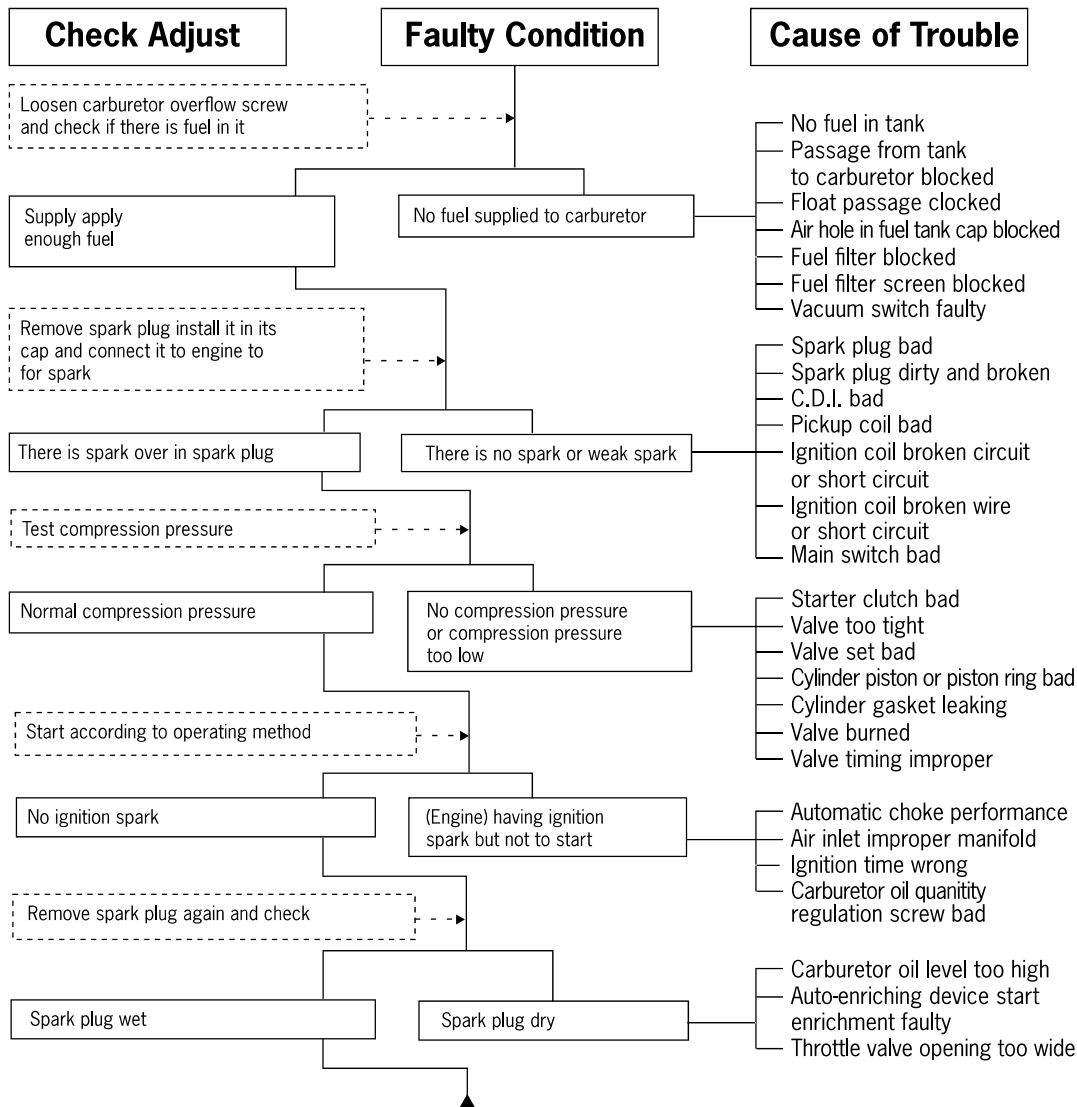

1. General Information

Trouble Shooting Guide (under speed, no power)

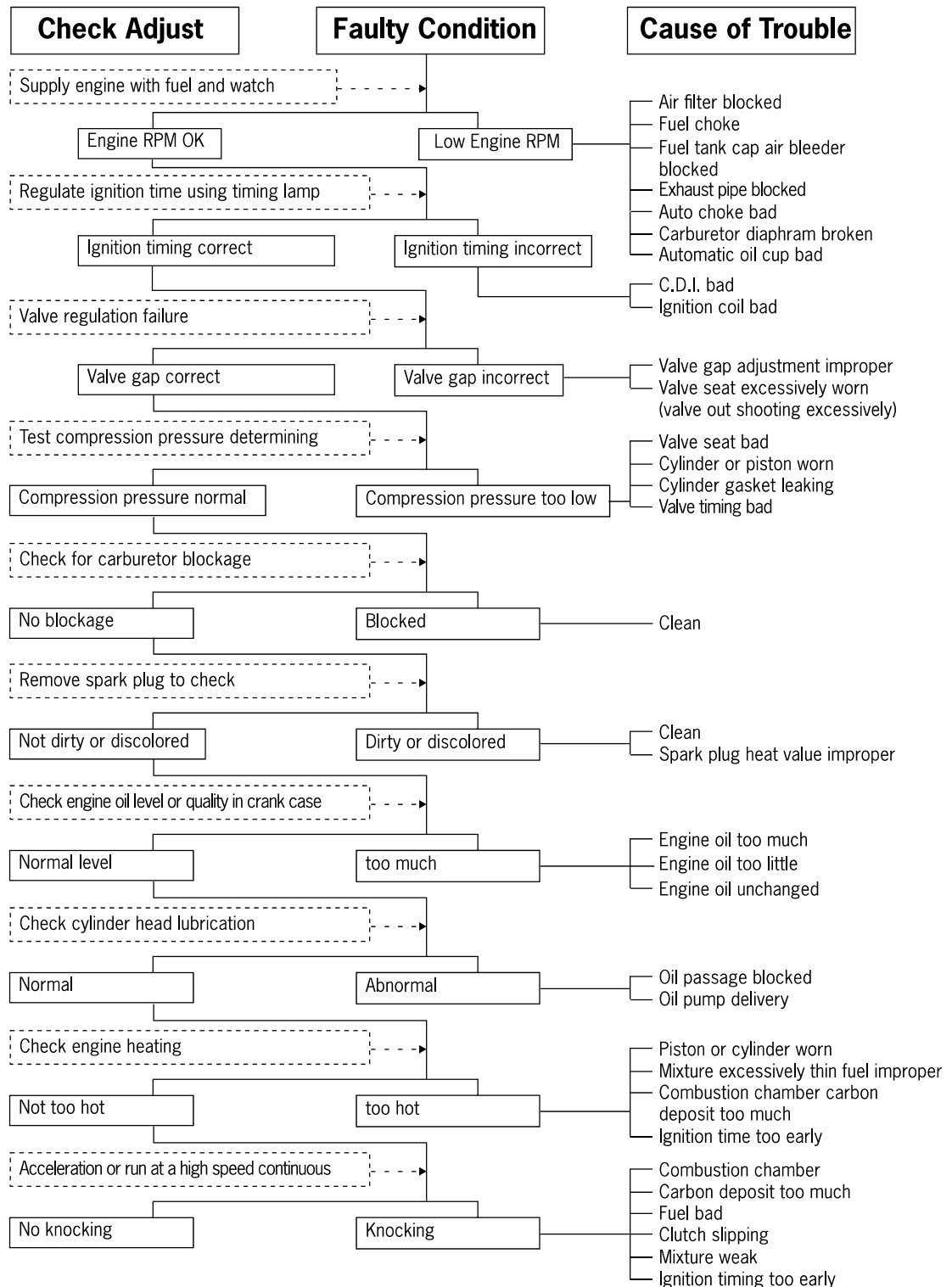

1. General Information

Trouble Shooting Guide (under speed, no power)

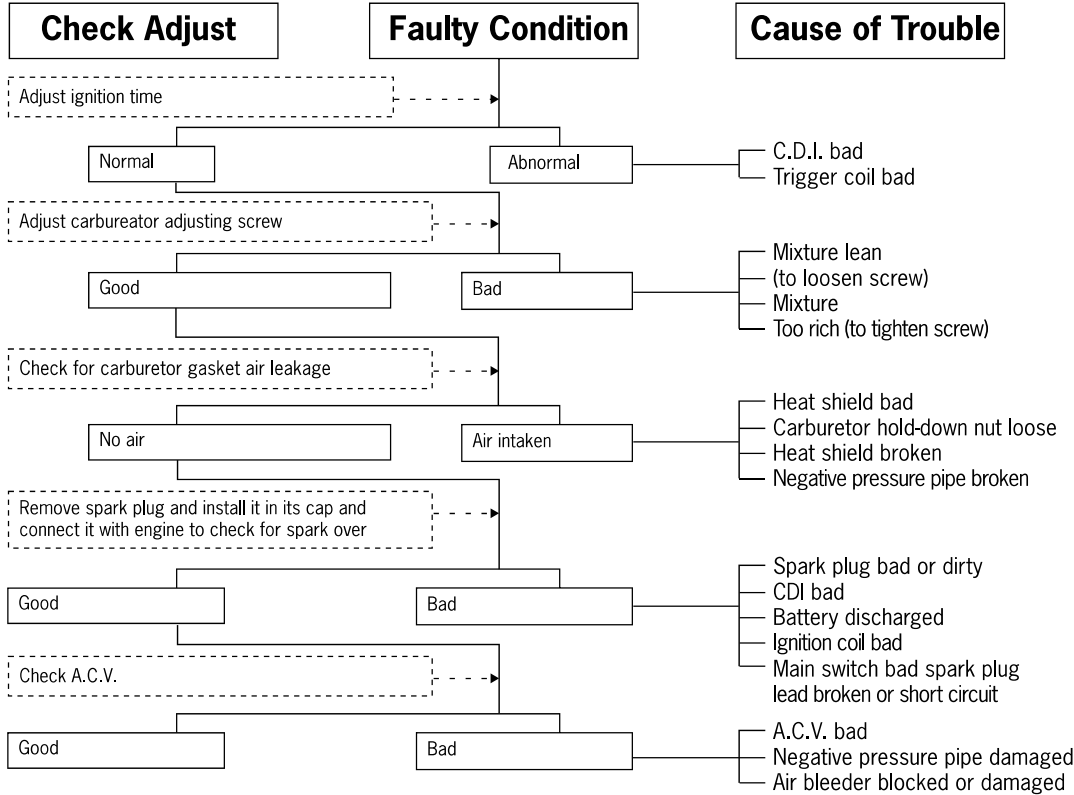

1. General Information

Trouble Shooting Guide (high speed)

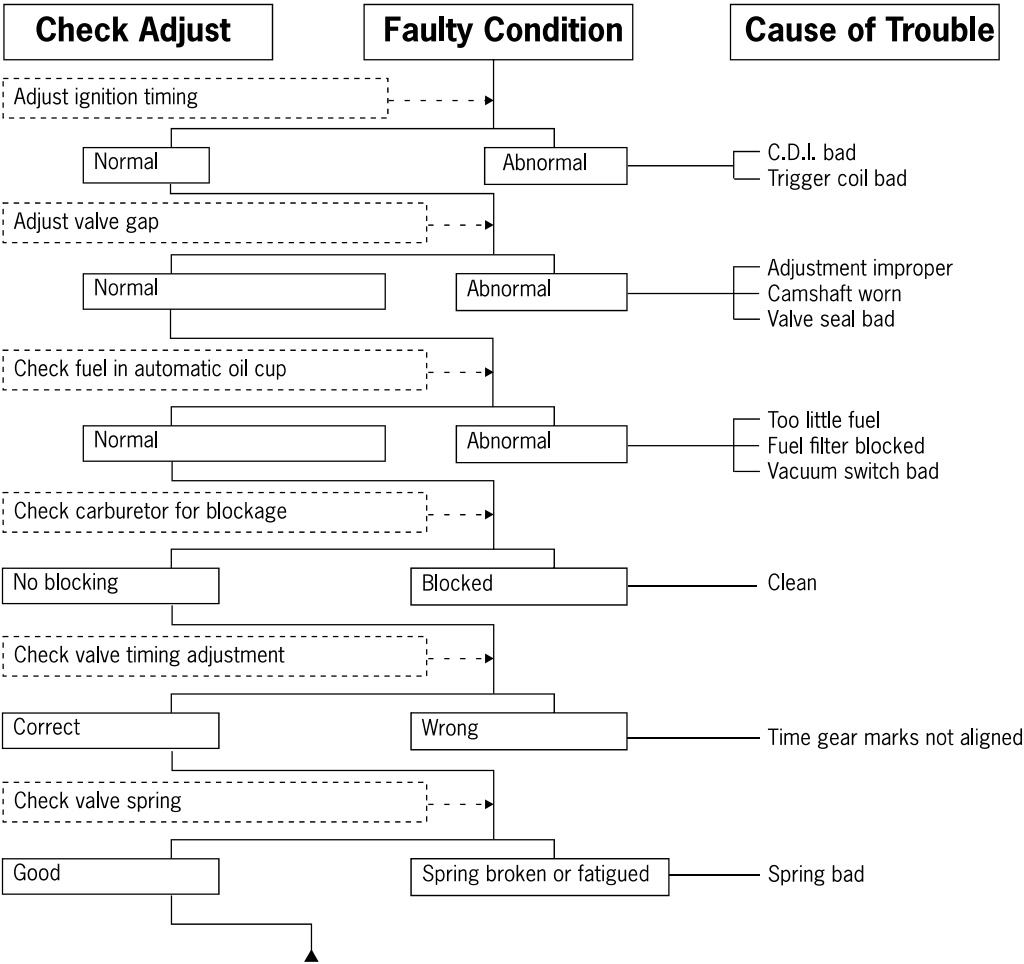

1. General Information

Trouble Shooting Guide (no spark)

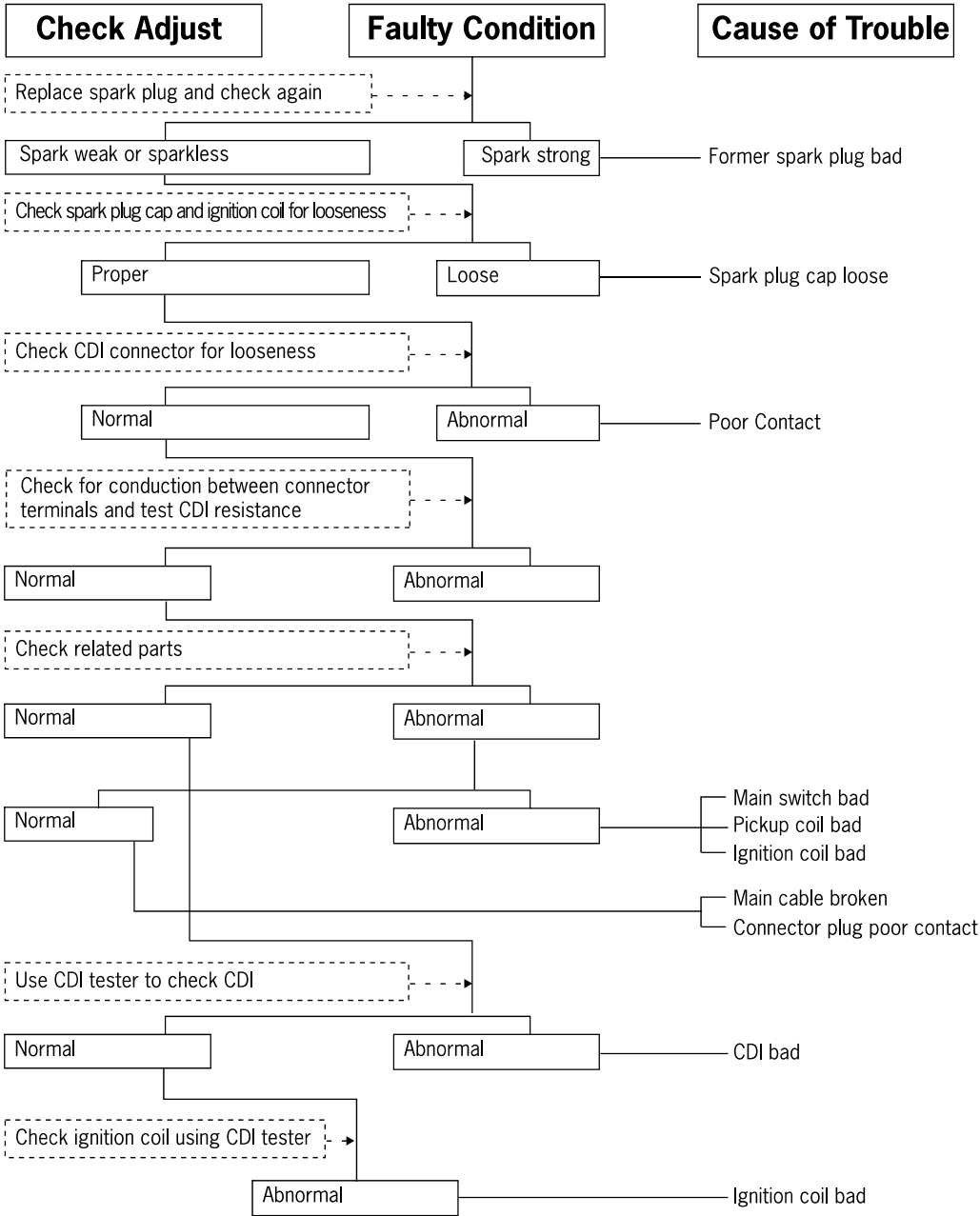

2. Scheduled Maintenance

Fuel Filter

1. Remove luggage box (2-2)
2. Check fuel line for ageing or damage.
3. Replace with a new one in case damaged or leaking.

Throttle Lever Operation

1. Check throttle for proper operation.
 2. Check throttle grip free play.
Free play: 2-6mm (.078 in.-.236 in.).
 3. Adjust free play using the adjusting nut in the throttle cable and the adjuster at the carburetor.
- Major adjustment should be made at carburetor.
 - Adjust it by loosening the jam nut and rotating adjusting nut.
 - Fine adjustment should be made at the throttle grip.
 - Remove outer cover, loosen jam nut and rotate adjusting nut to adjust it.

2. Scheduled Maintenance

Air Filter

Filter Replacement

1. Remove air filter cap, fix screw and remove the air filter cap.
2. Check filter for dirt or damage. Replace as necessary.

Do not attempt to clean the filter element.

Replacing Frequency

1. More frequent replacement is required if vehicle is driven on dusty roads or in the rain.
2. Make sure the air filter cover is securely in place.

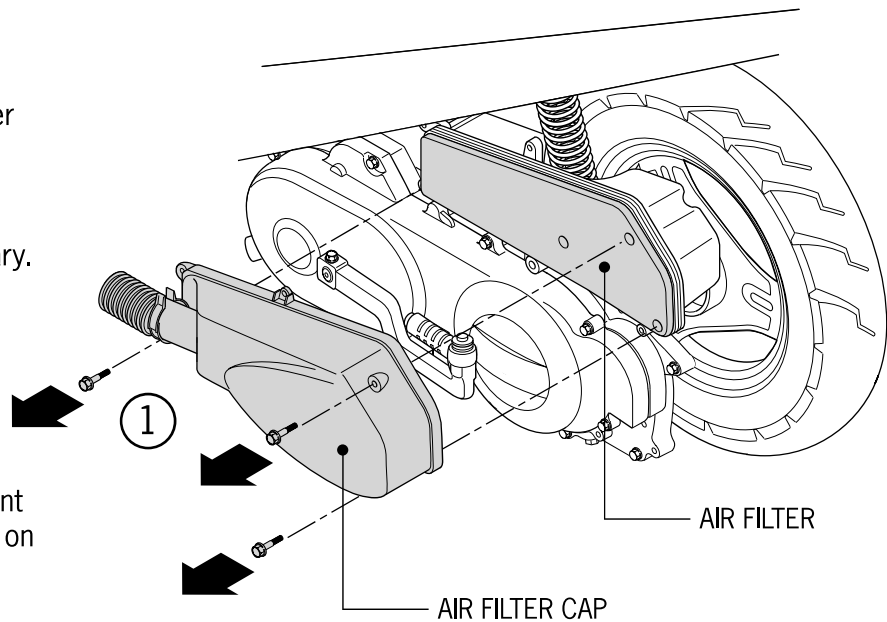

Spark Plug

1. Remove spark plug.
2. Check spark plug for burning, dirt or deposit.
3. Clean it with a spark-plug cleaner or steel brush in case of dirt or carbon deposits.

Specified spark plug:
NGK: C7HSA Champion
Check spark plug gap
Gap: 0.6-.07mm (.022-.024 in.)

4. Check plug for dirt, carbon build-up or cracking of insulator.

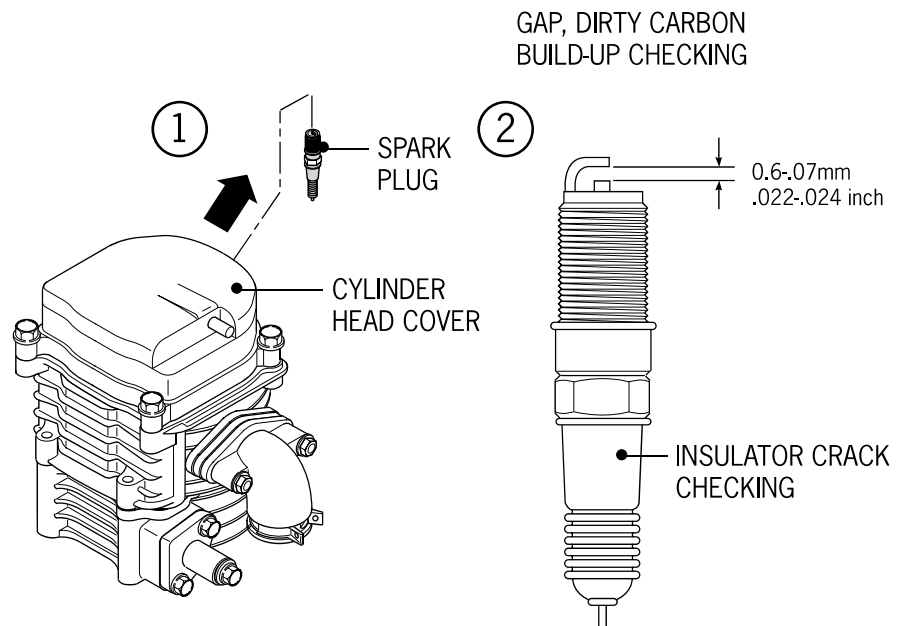

2. Scheduled Maintenance

Valve Adjustment

- Always check and adjust with engine temperature lower than 35°C (95°F)

1. Remove cylinder head cover.
2. Rotate cooling fan to camshaft. Locate mark at center top, aligning magneto fly wheel mark with that on crankcase. Magneto "T" mark and box crankshaft mark.

Valve gap checking and adjustment valve gap:

IN: 0.05mm (.00197 in.)
EX: 0.05mm (.00197 in.)

3. To adjust the valve gap, loosen am nut and rotate adjusting nut.

Valve Adjustment Wrench

- Be sure to check valve gap again, after locking jam nut.

Carburetor Idle Speed

- Idle adjustment should be made with the engine warmed up.

1. Remove cover.
2. After the engine warms up, connect it to an engine revolution counter.
3. Adjust idle screw until specified revolution is obtained.

Minimum idling speed: 1900+190rpm

4. Readjust the screw if the idle speed is not steady or fuel cannot be properly applied.

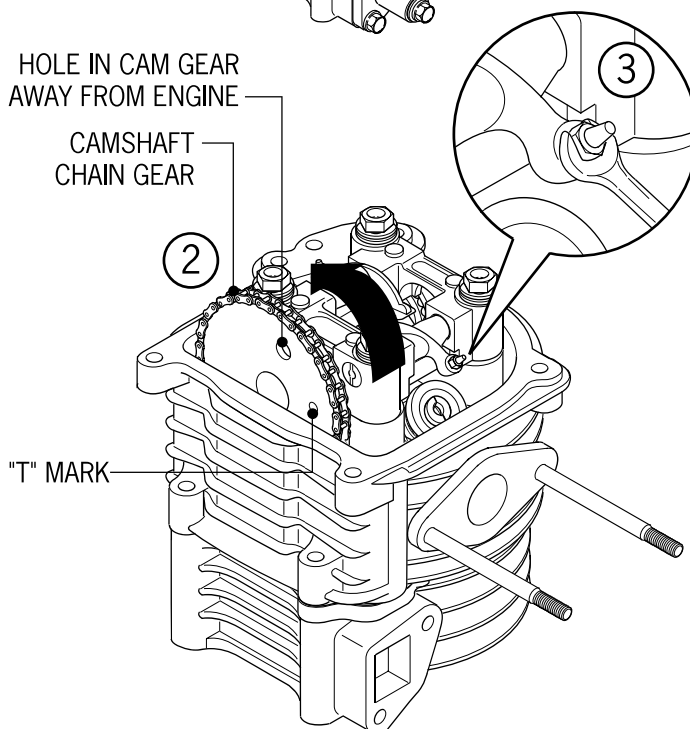
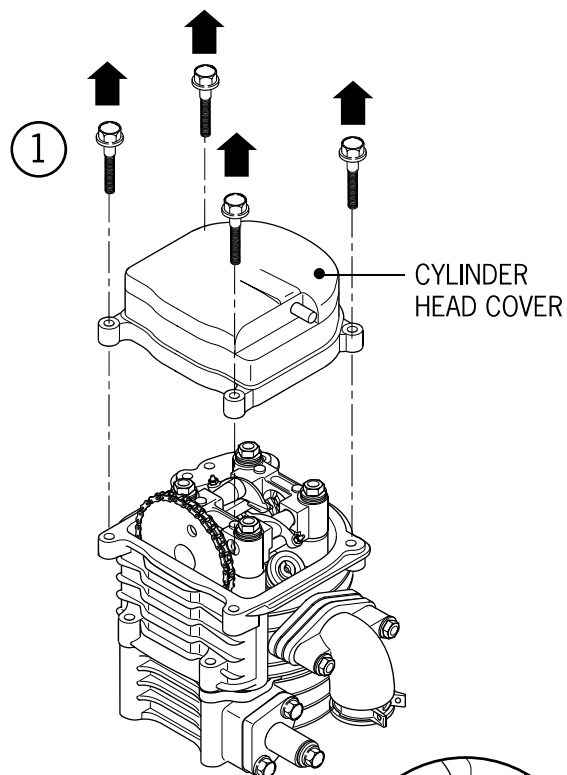

2. Scheduled Maintenance

Ignition Time

- Equipped with CDI, there is no need for ignition setting.
- Check ignition system if ignition time is incorrect.

1. Dismount right body cover.
2. Remove ignition timing inspection.
3. Check ignition timing using the timing light. Crankcase mark must be aligned with mark "F" on flywheel while engine is at idle speed. The timing should advance as the RPM is increased.

The timing mark should align with the crankcase mark at 3000 RPM.

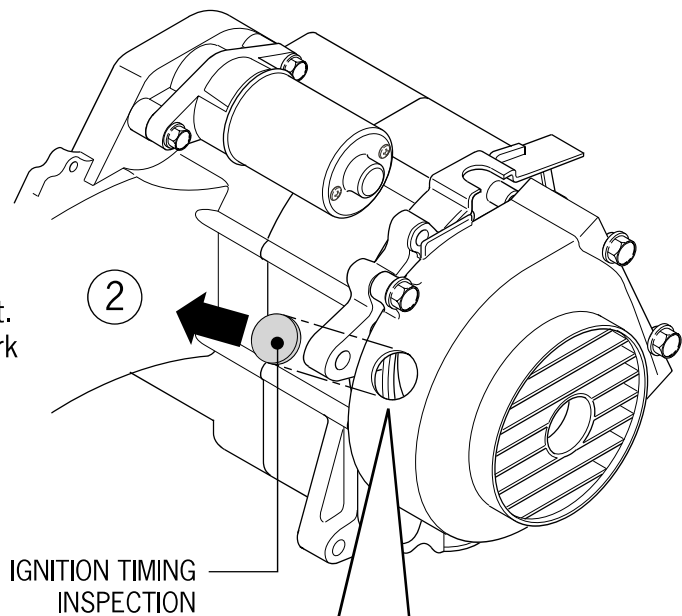

Cylinder Pressure

1. Measure cylinder pressure with the engine warmed up.
2. Dismount middle luggage box and middle cover (2-2).

Remove spark plug.

1. Install cylinder pressure gauge.
2. With throttle valve fully open, start starter motor to measure cylinder pressure. (213psi)
3. Compression pressure: 15kg/cm²-600rpm.
4. If the pressure is excessively low, check for the following:

- Valve leakage
- Valve gap too tight
- Cylinder head gasket damaged
- Piston ring worn
- Piston or cylinder worn

5. Check combustion chamber and piston top for excessive deposit if compression pressure is too high.

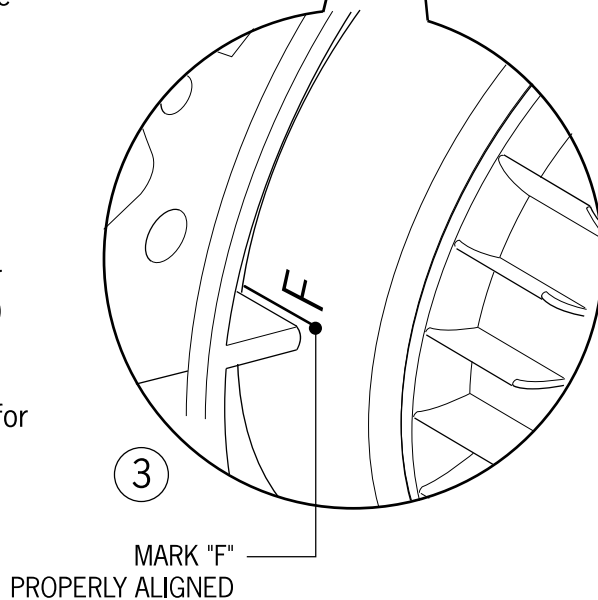

2. Scheduled Maintenance

Final check of gear engine oil reduction



Checking oil volume, build up main foot rest so that build up body becomes vertical on plain ground.

1. Dismount gear oil adjusting bolt after stopping engine.
2. The oil level should be just under the regulation screw bolt hole. Add gear oil when oil level is too low.

- Gear oil recommended: SAE 90W

3. Build up gear oil regulator screw bolt.
4. Confirm whether or not the packing washer is broken.

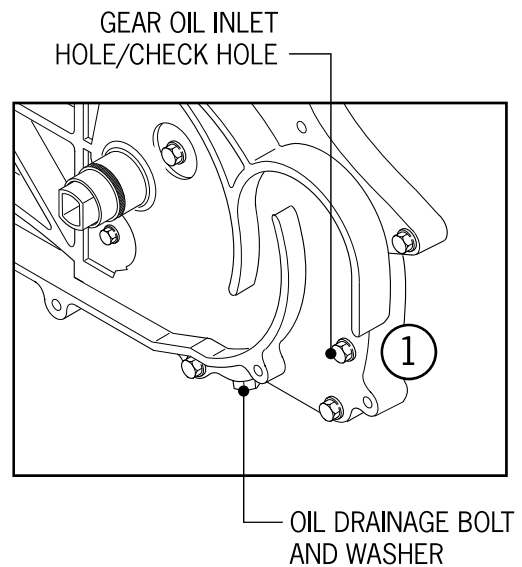

Changing Gear Oil

1. Remove gear oil adjusting bolt and drain oil.
2. Confirm whether or not packing washer is broken.
3. Add recommended gear oil.

- Gear oil capacity: 0.12l-40ES
- Bolt torque: 0.9kg-m 780 lbs.

4. Check if there is any leakage after work is performed.

Transmission Belt

1. Detach the left crankcase cover (9-2).
2. Check whether there is wear and tear of transmission belt.
3. Change with new one when necessary or during timely maintenance.

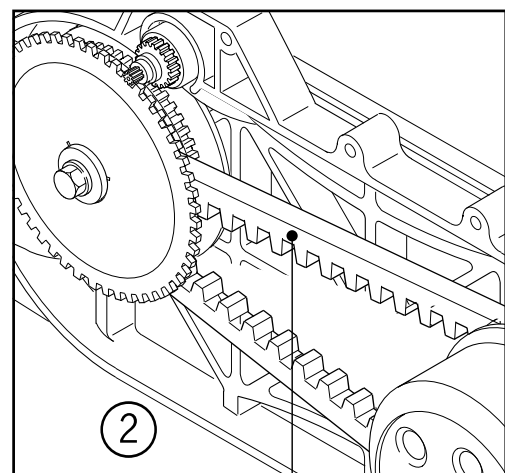

TRANSMISSION BELT

3. Lubricating System

Lubricating System

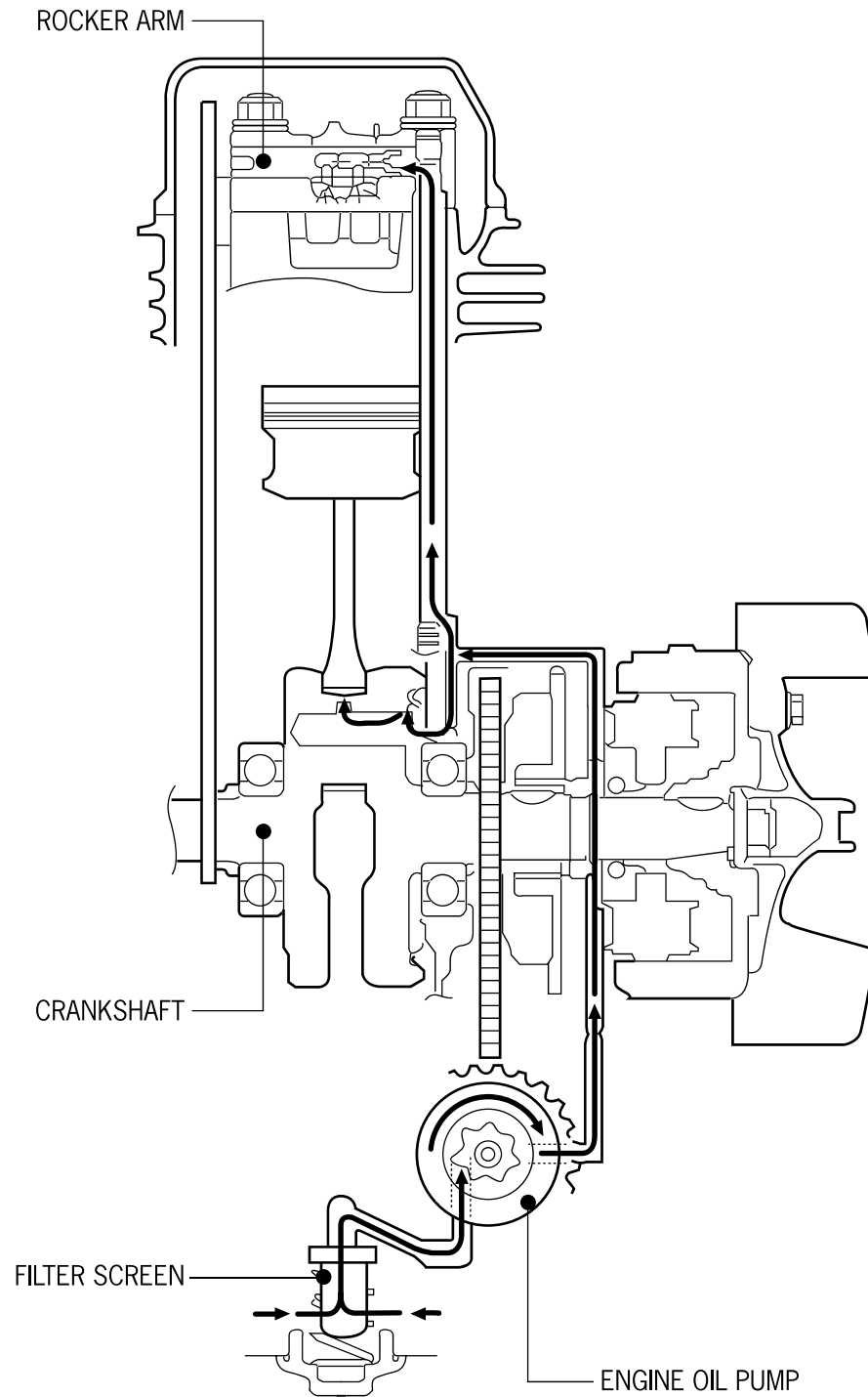

3. Lubricating System

Topic	Page	Topic	Page
Overall engine requirements	4-2	Engine Oil Pump Removal	4-4
Problem diagnosis	4-2	Oil Pump Disassembly	4-5
Engine oil/filter screen	4-3	Checking	4-5
Oil Volume	4-3	Assembling	4-6
Oil Changed	4-3	Installation	4-6

Overall Engine Requirements

Special Attention

Use proper motor oil SAE 10W 30.

Use only clean, fresh oil.

Do not rebuild oil pump. Replace with a new pump when needed.

Check for leakage after replacing pump.

Basic Material

Item		Nunmul value	Replace at
Engine oil pump	Gap between inner rotator and external rotor	—	0.12mm .005in
	Gap between external rotor and pump body	—	0.12mm .005in
	Gap between and surface of rotor and pump body	0.05-0.10mm .001-.004in	0.2mm .008in

Problem Diagnosis

Loss of engine oil

- Engine oil natural consumption.
- Engine oil leakage.
- Piston ring wear, bad assembly.
- Valve guide oil seal is worn.

No oil pressure

- Pump worn.
- Use of wrong oil.
- Oil level low.

Engine burning excessive oil

- Blocked oil passage.
- Use of wrong oil.
- Worn rings.
- Valves worn or damaged.

3. Lubricating System

Engine Oil/Filter Screen

Oil Volume

1. Check oil with scooter parked on level ground on center stand.

- Scooter must be on center stand when oil volume is checked.
- Run engine for two or three minutes and then turn it off. After two to three minutes, check the oil level.

2. Check the oil level when the oil dipstick is unscrewed and out.
3. Add oil to upper limit level on the dipstick.

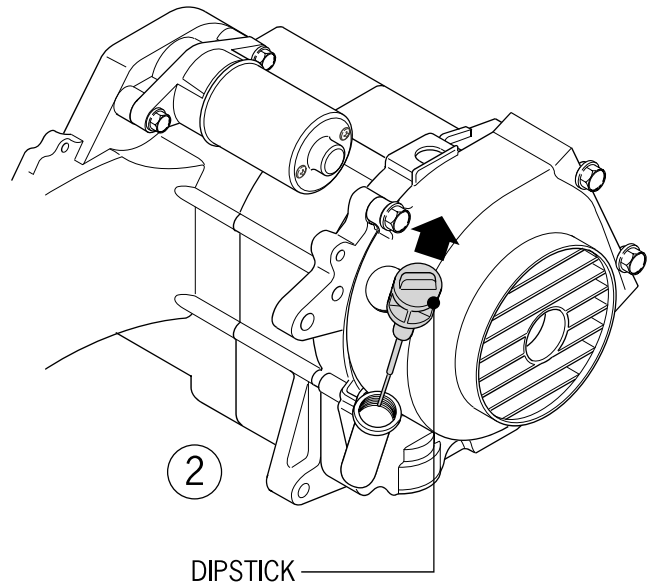

Oil Changed

- It is easier to drain oil when motor is warm.

1. Remove drain bolt to completely drain oil.
2. Disassemble the oil filter screen cover and take off the oil filter screen. Use high-pressure air to clean the filter screen. Wash with solvent and dry before reinstalling.

3. Check o-ring for damage. Replace if necessary.
4. Assemble engine oil filter screen and filter screen cover.

- Torsion value: 1.4kg-m
1300 ft lbs

5. Add assigned oil to determined volume.

- Engine oil capacity: 0.8L
- 320ES

6. Check for oil leaks.
7. Run engine for 1-2 minutes at idle speed.
8. Turn engine off and check oil level. Add oil if needed.

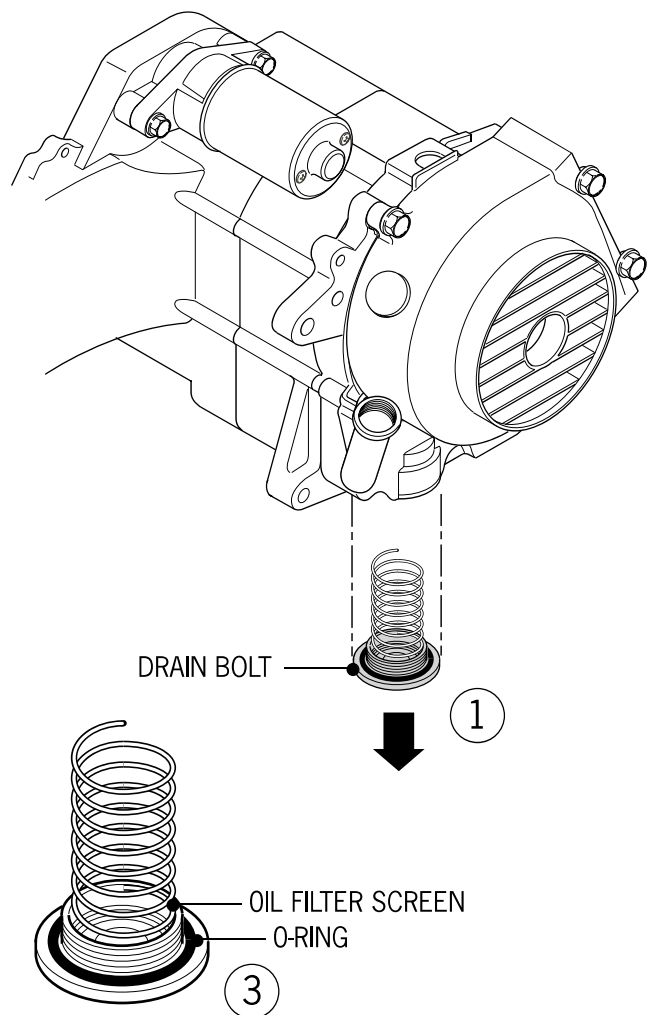

3. Lubricating System

Oil Pump Removal

1. Remove engine right outer cover fan magnetor.
2. Remove alternator rotor.
3. Remove stator pules coil.
4. Remove eight bolts of right crankshaft case cover and take off crankshaft case cover.
5. Remove washer and fixed pin.
6. Remove the fixed nut of the gear in the oil pump.
7. Take off the gear of the oil pump.
8. Remove fixed bolts of oil pump module body.
9. Take off oil pump.
10. Take off two o-rings.
11. Check o-rings for damage.
12. Replace if necessary.

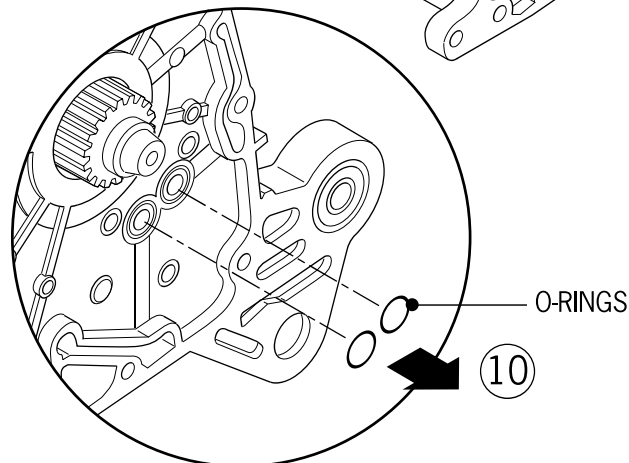
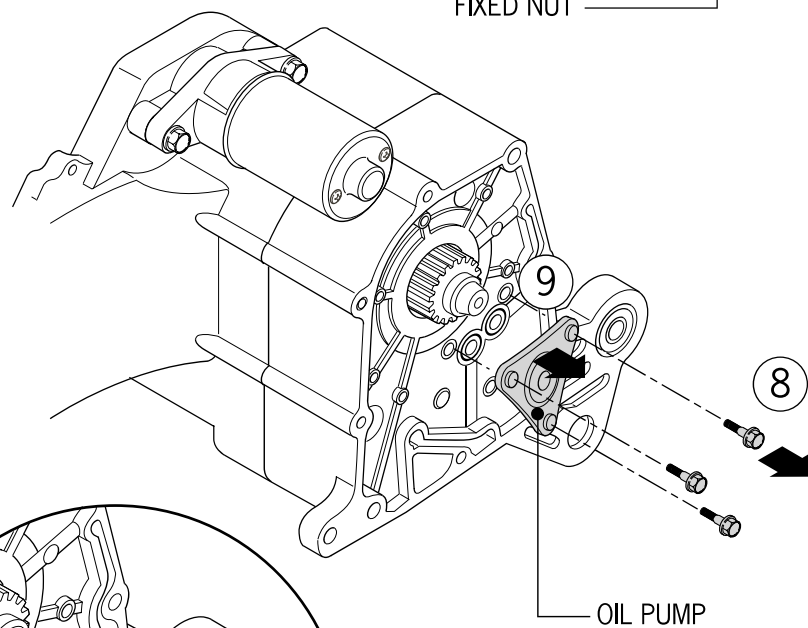
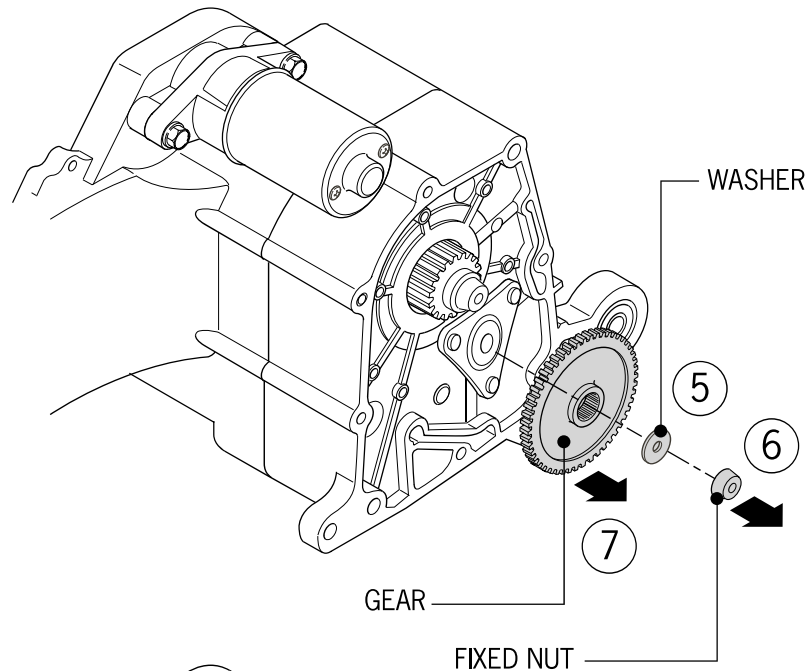

3. Lubricating System

Oil Pump Disassembly

1. Remove three fixed screws in oil pump body.
2. Disassemble oil pump.

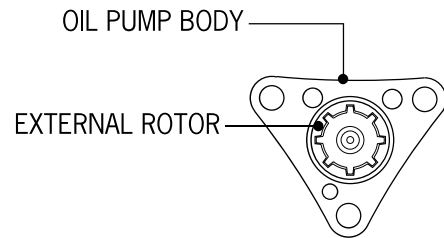
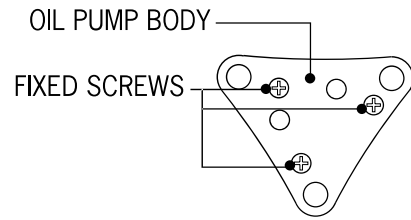

Checking

1. Check the gap between the oil pump module body and the external rotator.
 - Used limit: 0.12mm (.005 in.).
2. Check the gap between the surface of the rotator and the body.
 - Used limit: 0.2mm (.008 in.).

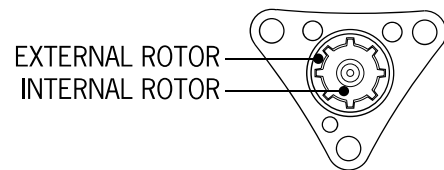

3. Lubricating System

Assembling

1. Assemble inner and outer rotors and oil pump shaft.



Be careful of alignment between pump bearing unfilled corner and inner rotor unfilled corner.

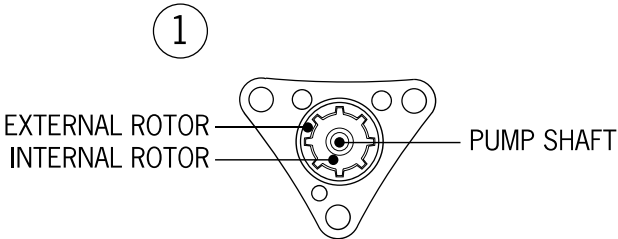

2. Assemble pump cover and tighten screws.

Installation

1. First put two o-rings at the oil pump seat.

2. Put oil pump in the crankshaft case.



First add oil to pump and then assemble.

3. Tighten the three fixed screws.

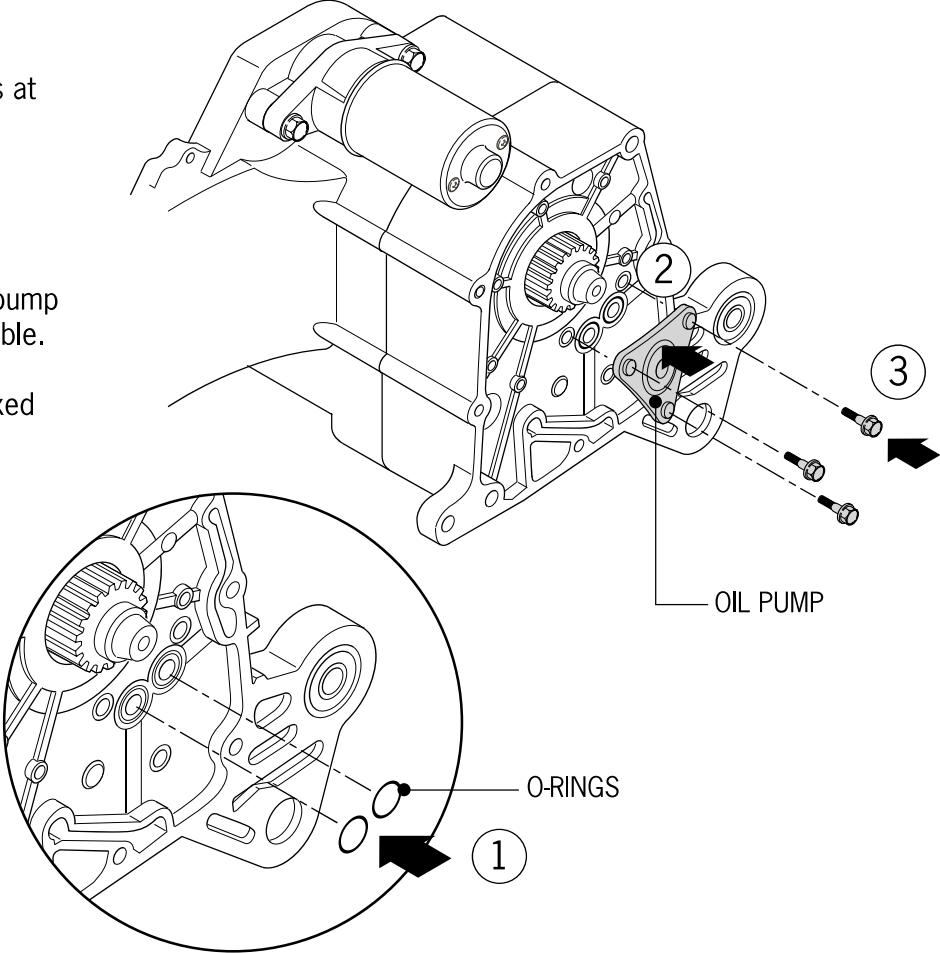

3. Lubricating System

4. Install gear of oil pump and then fix nut.

- Torsion value: 0.8-1.2kg-m
- 7-8ft lbs

5. Assemble right crankshaft case cover, 8 screws and tighten.

6. Assemble pulse coil, stator and rotor.

7. Install fan and cover.

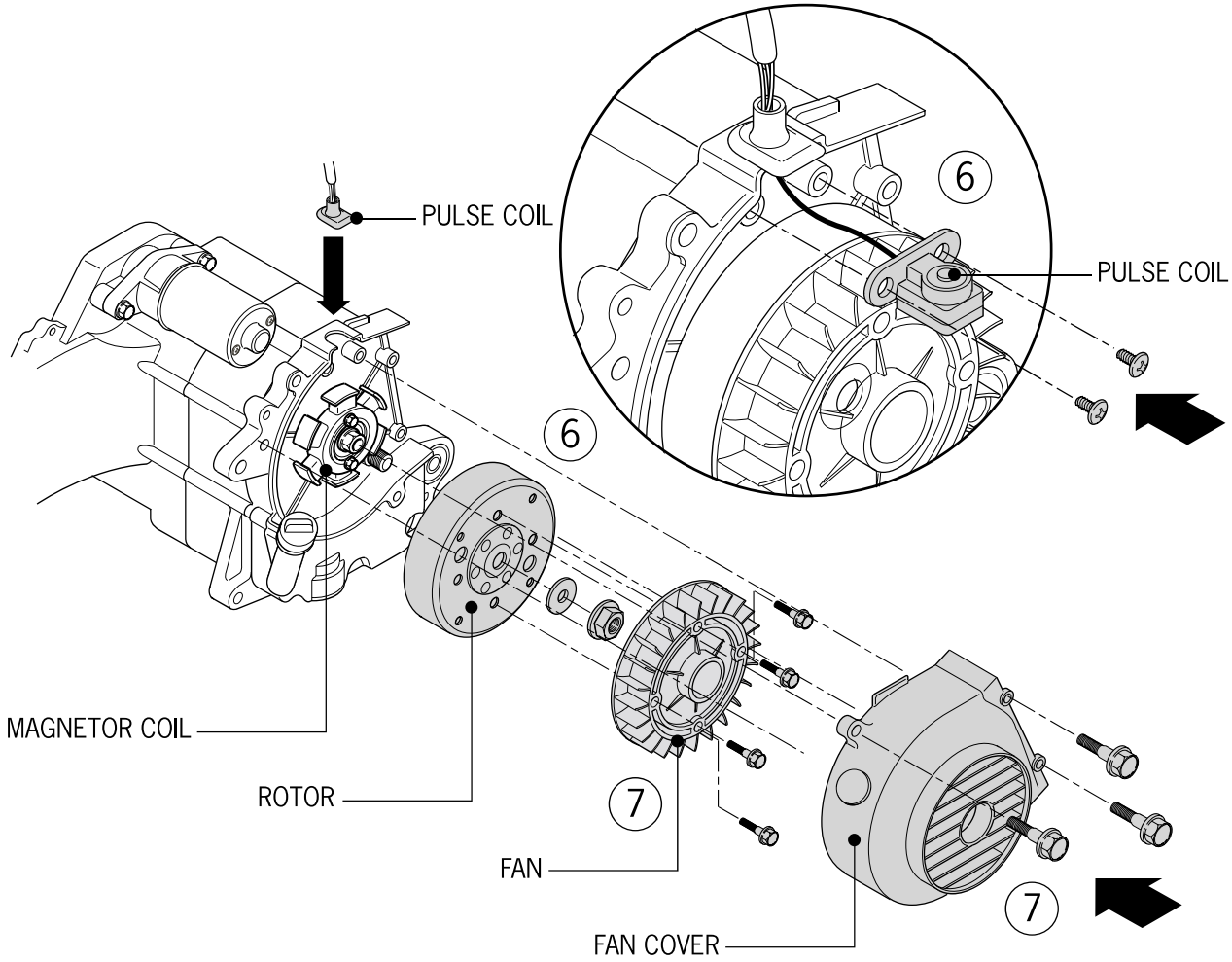
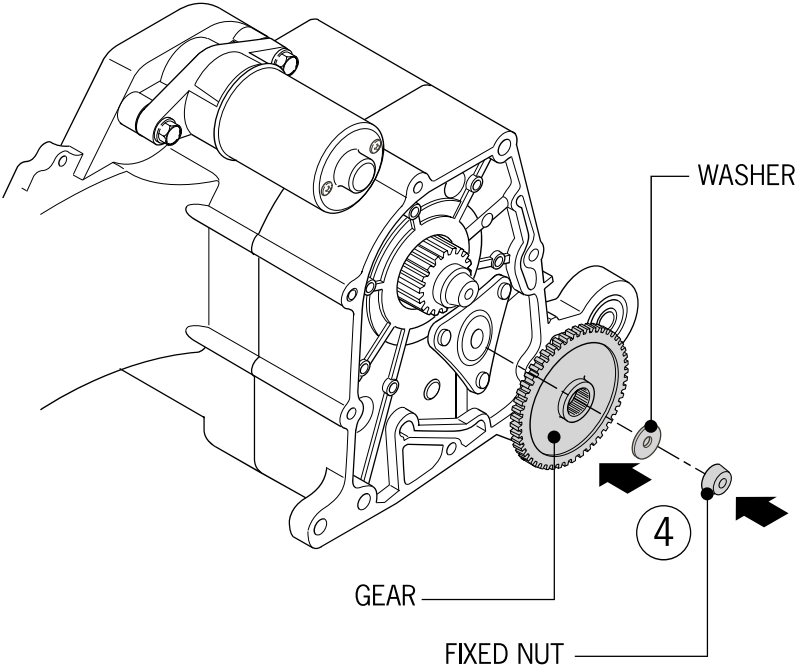

4. Fuel System

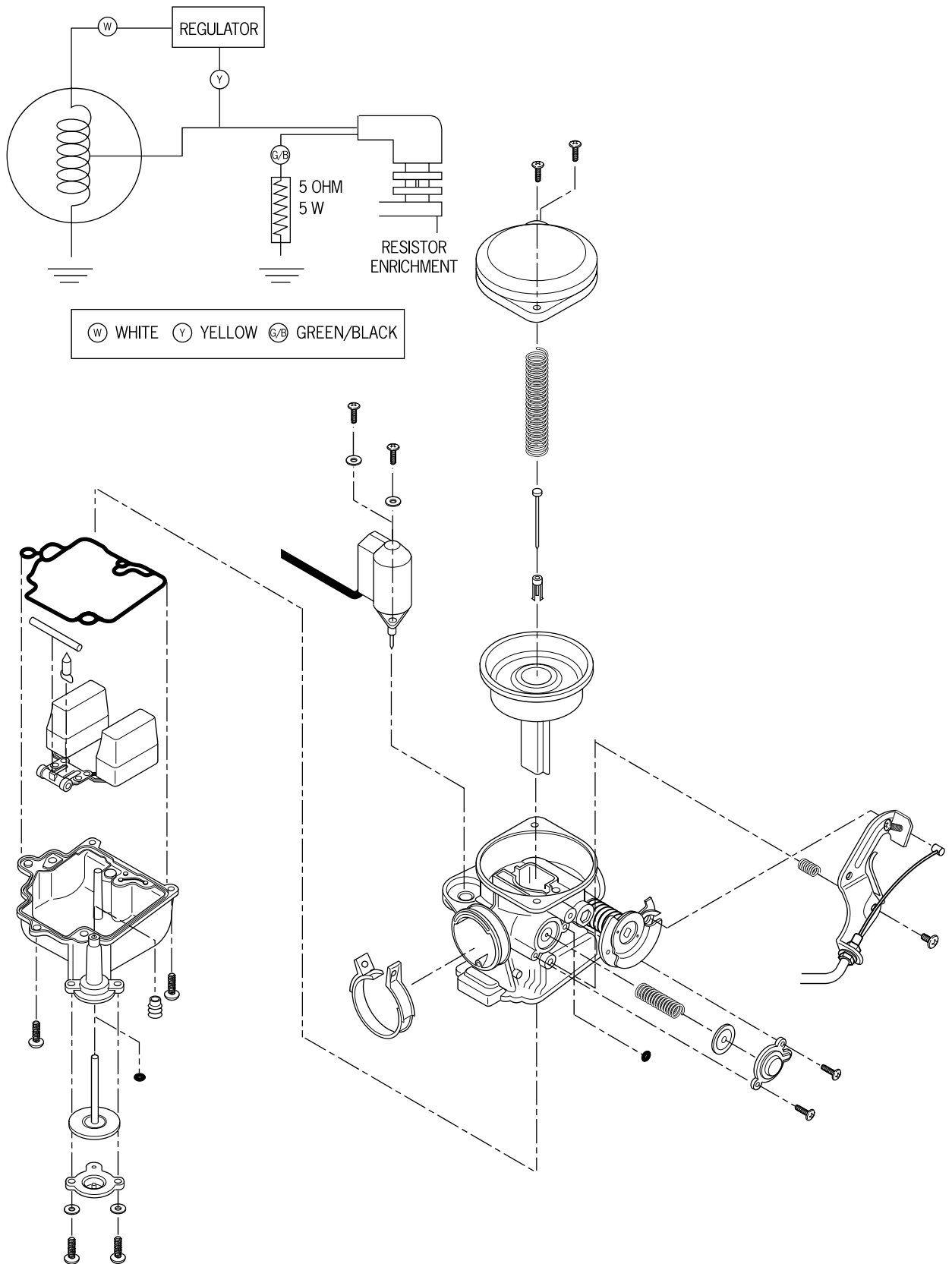

4. Fuel System

Topic	Page	Topic	Page
General information	5-2	Disassembly of Accelerator Pump	5-10
Troubleshooting	5-3	Checking Accelerator Pump	5-10
Disassembly of Carburetor	5-4	Assembly of carburetor	5-11
Checking Auto-choke	5-4	Disassembling Fuel tank	5-12
Air cutoff valve	5-6	Assembly of Fuel Tank	5-12
Assembling	5-6	Carburetor Adjustment	5-13
Vacuum Chamber-Break Down	5-7	Automatic Fuel Valve	5-14
Assembly of Vacuum Chamber	5-7	Fuel Meter Sending Unit	5-14
Float bowl and Disassembly	5-8	Air Filter Inspection	5-15
Checking Float Valve	5-9		

General Information



Warning!

Work on the fuel system in a well-ventilated area that is free of sparks or open flames. Do not breathe the vapors from the gasoline. Wear protective gloves to prevent skin irritation.

- Open the bowl drain and allow all gasoline in the carburetor to drain into an appropriate container prior to removing or servicing it.
- Remove control cables and wires carefully to prevent damage.

- Check all o-rings for damage. Replace as necessary.

- Remove carburetor from the scooter before attempting to service the fuel bowl or vacuum canister.

- When cleaning the carburetor, remove the vacuum diaphragm before using air or solvents for cleaning. This will prevent damage to the diaphragm.

- When storing the scooter for a period of time exceeding one month, use a quality fuel stabilizer to prevent deterioration of the fuel and damage to the carburetor.

Repairing material

Specification	Standard valve
Carburetor type	Constant velocity-CVK
Venturi Bore	17mm (.67 in.)
Fuel Level	mm
Main jet	
Idle jet	.27 mm (.12 in.)
Idle speed	1600 RPM
Throttle free play	5mm (.125 in.)
Mixture screw setting	3 turns out

4. Fuel System

Troubleshooting

Engine is hard to start

- No spark
- Low compression
- No fuel in carburetor
 - Blocked fuel line
 - Blocked fuel filter
 - Blocked vacuum line
 - Leaky vacuum line
 - Dirty float needle
 - Float set too high

Too much fuel to engine

- Blocked air filter
- Manifold air leak
- Bad auto choke
- Blocked air passage in carburetor

Air/fuel mixture too rich or too lean

- Bad auto choke
- Plugged idle jet
- Float needle stuck or dirty
- Float height too high or too low
- Blocked air passage in carburetor
- Dirty air filter
- Air leak at carburetor or manifold

Misfire under acceleration

- Poor spark
- Air mixture screw too lean
- Bad accelerator pump

Poor drivability

- Weak spark/bad ignition system
- Blocked fuel line
- Blocked fuel filter
- Bad fuel
- Water in fuel
- Air leak at carburetor or manifold
- Improper float level
- Bad auto choke
- Obstructed jet in carburetor
- Vacuum slide stuck
- Damaged vacuum diaphragm
- Dirt in carburetor

4. Fuel System

Disassembly of carburetor

1. Remove seat and helmet storage tub.
2. Remove right side body panel.
3. Disconnect cable connector for auto choke.
4. Loosen carburetor drain screw and drain fuel from float bowl.
5. Loosen clumps in intake tube and main fold.
6. Loosen throttle cable and remove from support and from throttle control plate.
7. Remove fuel line from carburetor.
8. Remove air inlet tube from carburetor and pull carburetor straight back out of intake manifold.
9. Remove auto choke from carburetor.

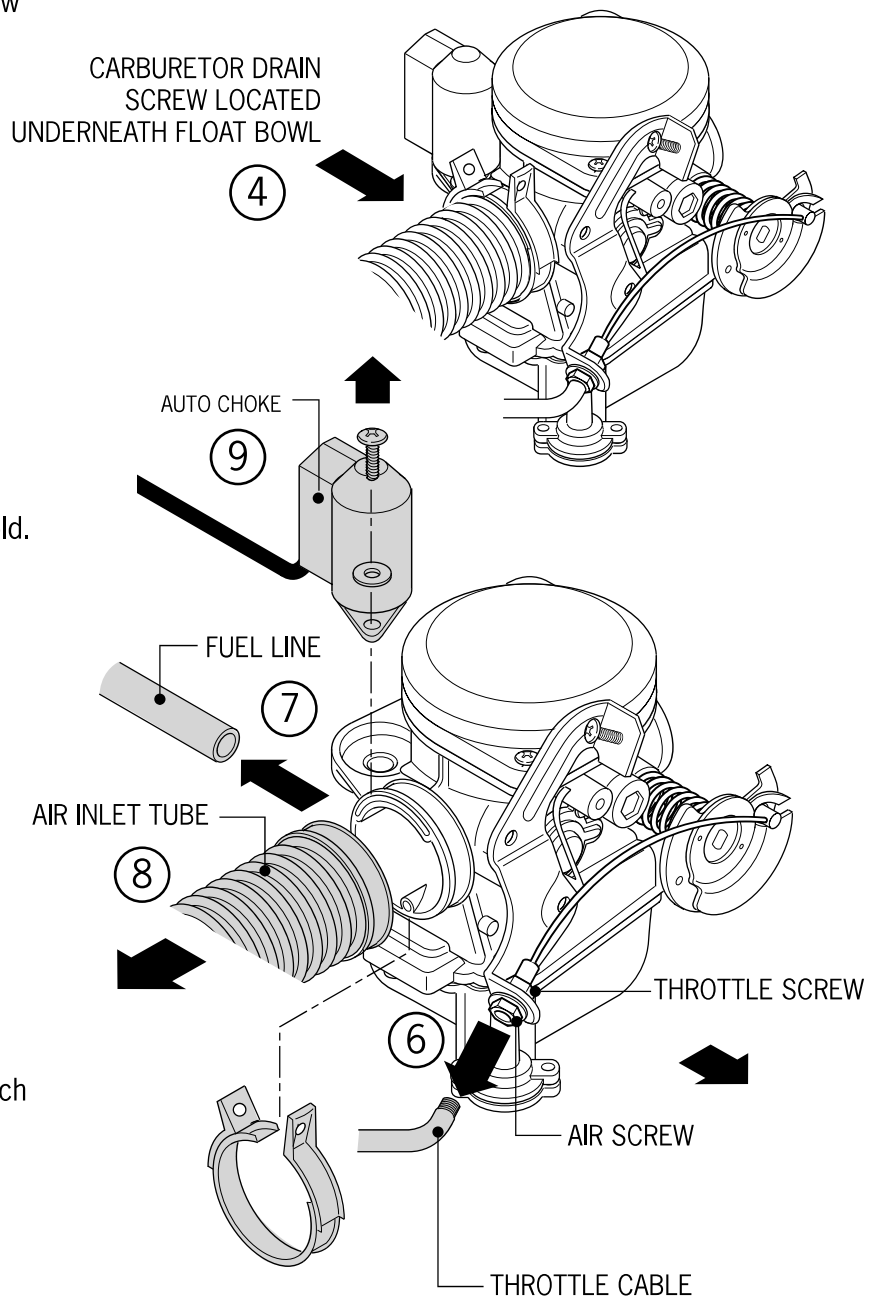
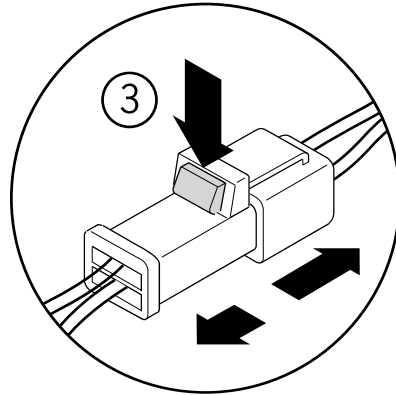

Checking Auto Choke

1. Check resistance volume.
2. Standard value below 5 when cold.
3. Connect auto choke to 12V battery.
4. Plunger should extend 3/8 inch in 5 minutes.

4. Fuel System

5. Check pin and seat for wear.

6. Replace if necessary.

7. Place auto choke in mounting location and press down firmly.

8. Put lock ring in position and fasten screw

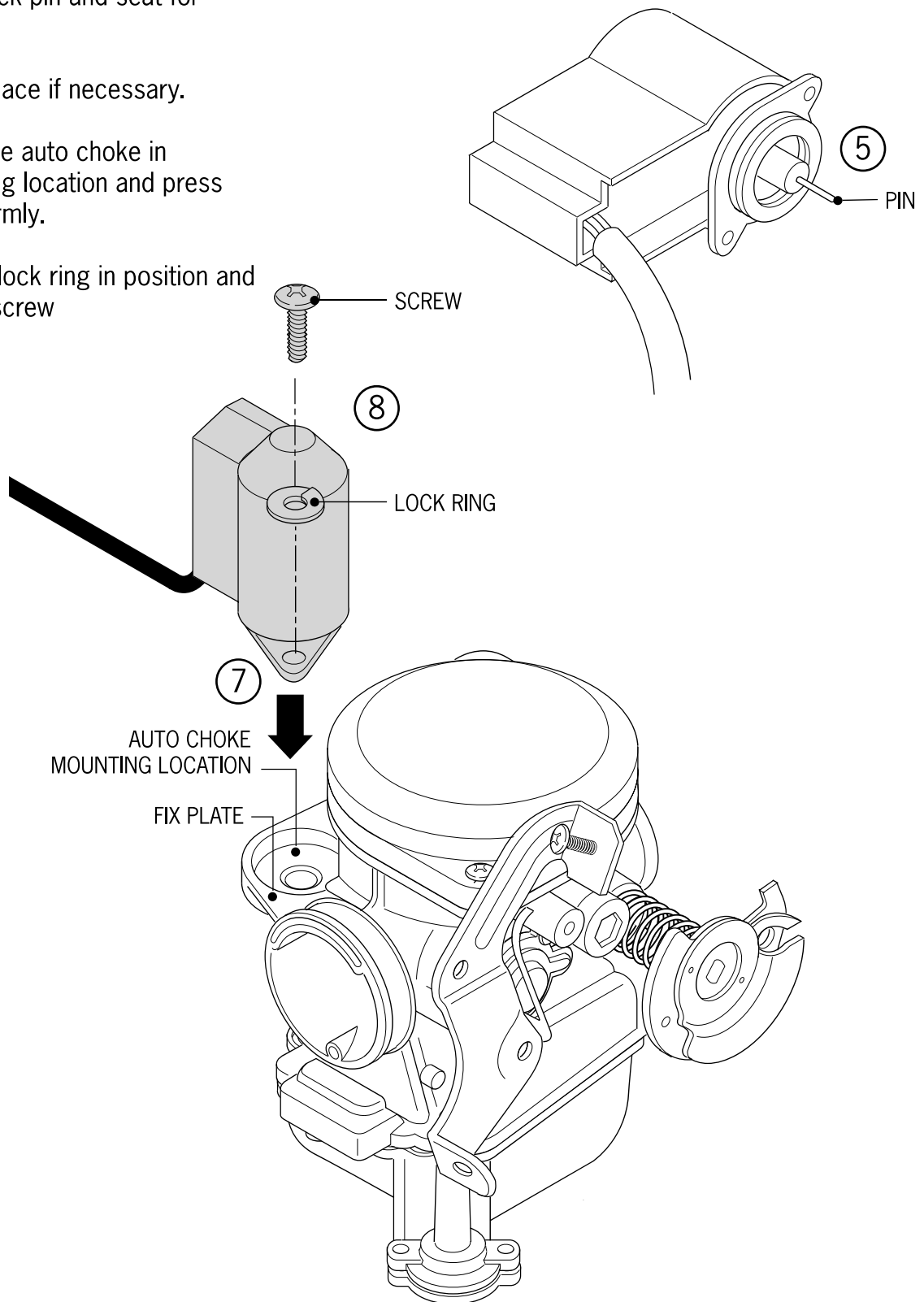

4. Fuel System

Air Cut Off Valve

1. Disassemble two screws in fuel guide fixed plate and remove fixed plate.
2. Disassemble two screws in air cut off valve.
3. Take off spring and vacuum plate.
4. Check for wear on plate, replace if necessary.
5. Clean the passage way to remove dirt or varnish.

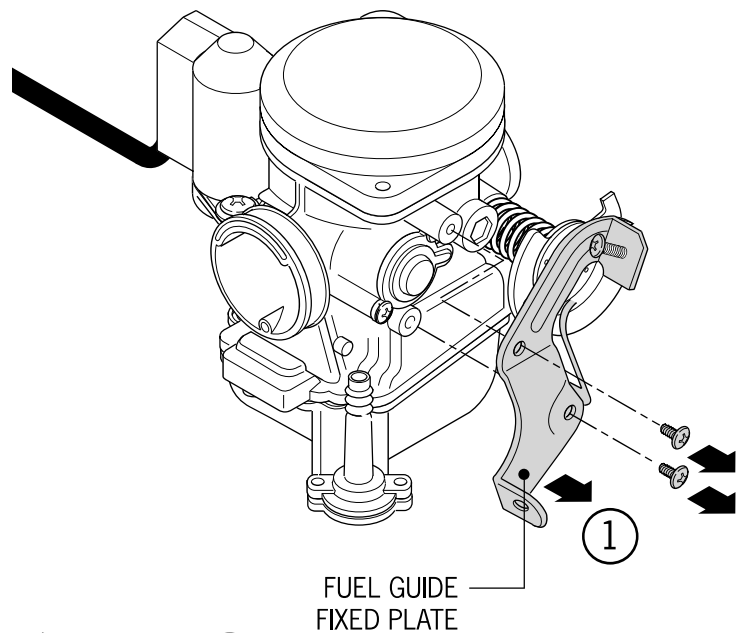

Assembling

1. Install plate to carburetor.
2. Install spring and cover of air cut-off valve.
3. Build up fuel guide line fixed plate and tighten two screws.

⦿ Be sure that furrow of vacuum plate is aligned with the carburetor groove.

⦿ Make sure that cover tightens into place.

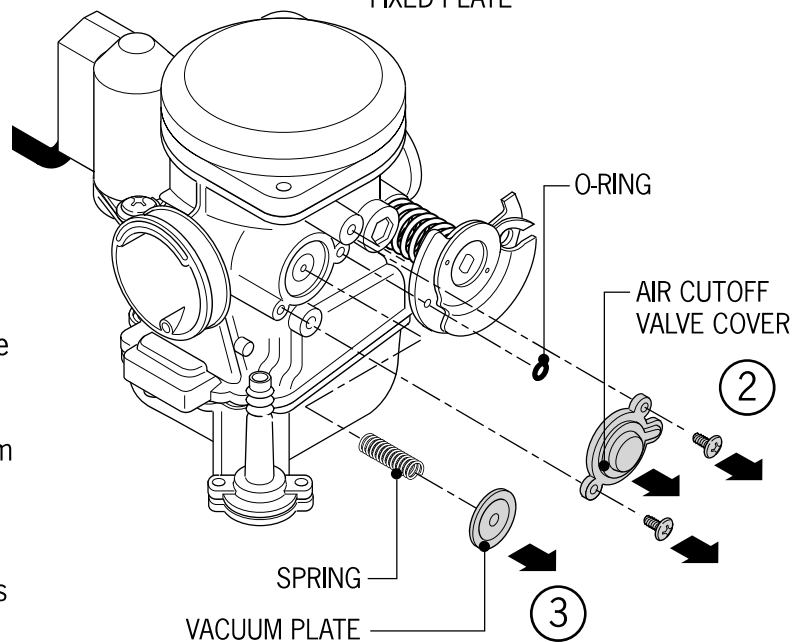

4. Fuel System

Vacuum Chamber-Break down

1. Remove two screws and take off cover.
2. Remove spring, diaphragm piston.
3. Remove fuel pin and slide.

⦿ Take special care not to damage diaphragm. Replace if damaged.

Checking

1. Check pin for wear and replace if necessary.

Assembling

1. Install piston or plate to body of carburetor.
2. Push the button of the piston to vacuum chamber side and keep open completely. Install spring and cover.
3. Install screw.

⦿ Be sure to hold slide and piston in up position when installing cover and tighten screw.

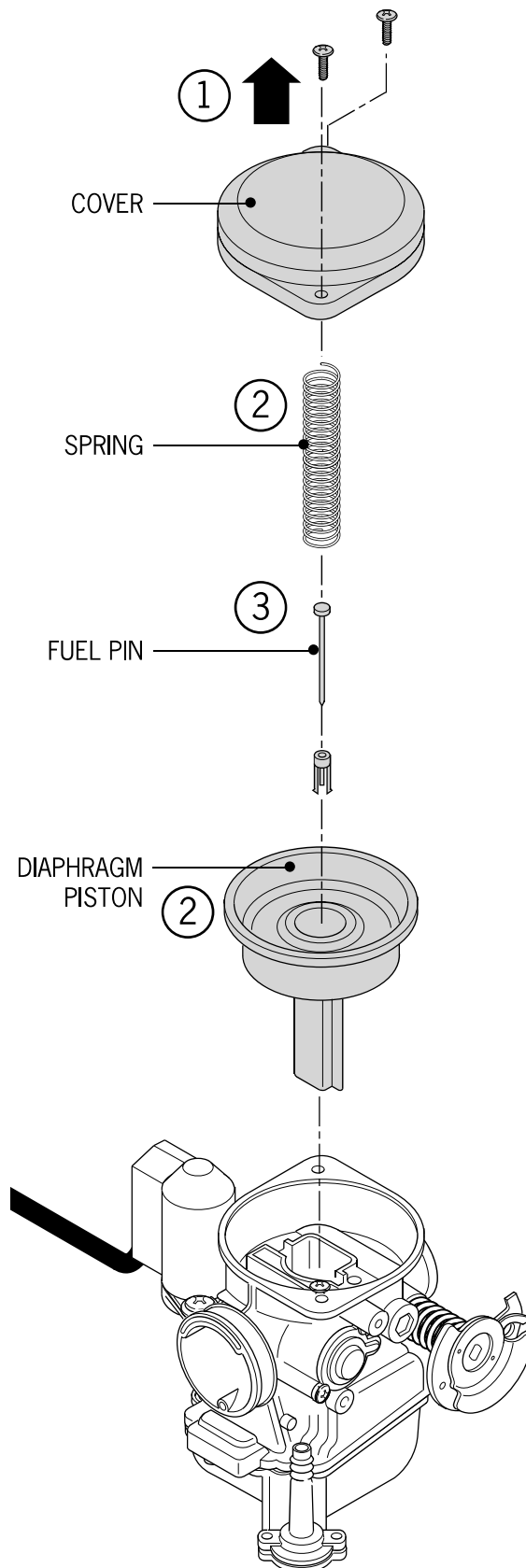

4. Fuel System

Float Bowl

Disassembling

1. Disassemble three screws and take off float bowl.
2. Remove float pin spring.
3. Remove high-speed jet, low-speed jet and fuel volume control screw.

- ⦿ Be careful not to break the fuel jets and control screw.
- ⦿ Count the turns when removing the fuel volume control screw.
- ⦿ When reinstalling jets and screws, do not over tighten.

4. Clean jets with solvent and compressed air.
5. Clean body of carburetor by blowing air through all passages.

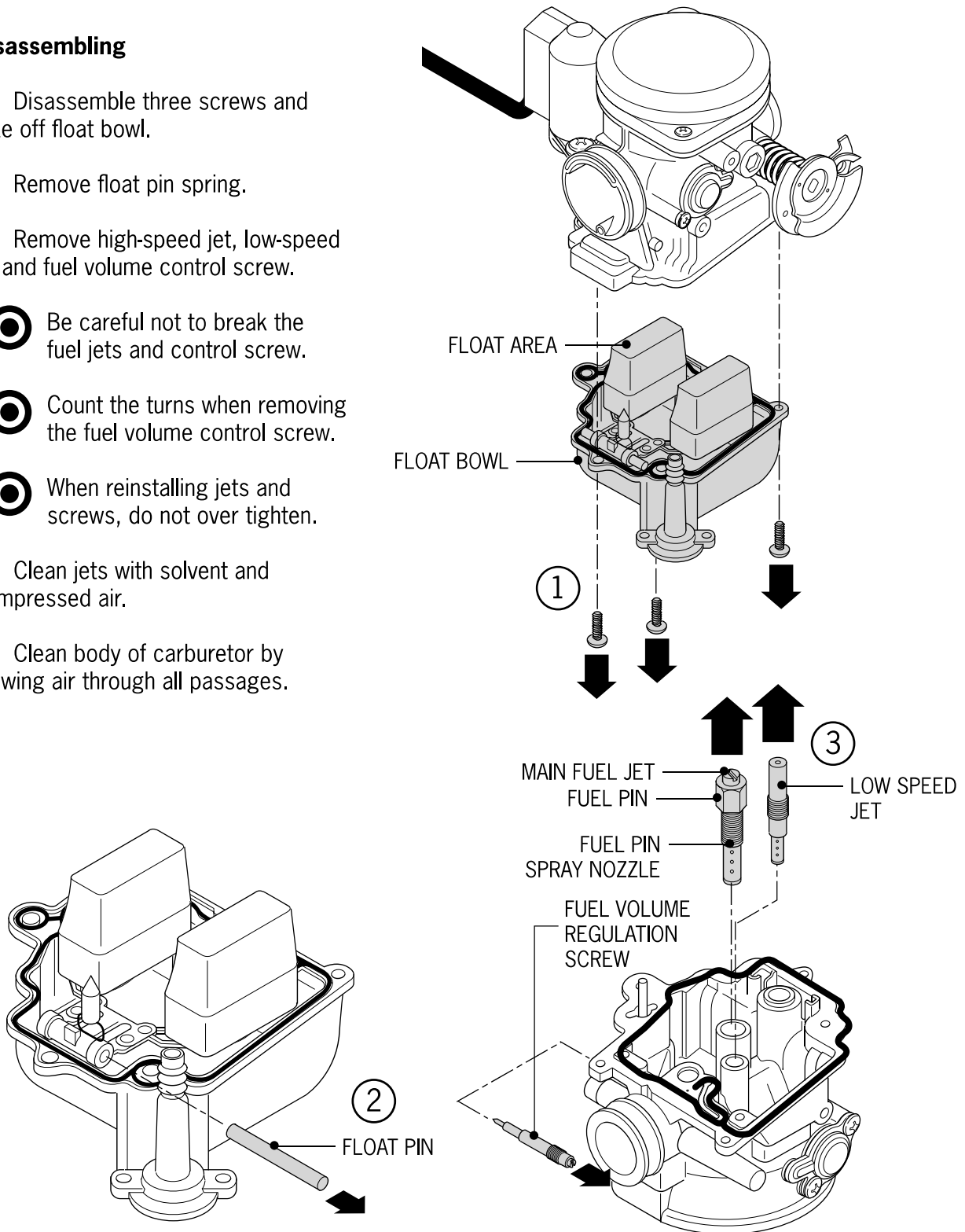

4. Fuel System

Checking

1. Check float valve and valve seat for damage.
2. Check float valve and valve seat wear, pitting or buildup of dirt.
3. Any leakage of the valve or a buildup of dirt will affect the fuel level in the float bowl and cause drivability problems.
4. Assemble the low speed jet, fuel pin spray nozzle, fuel pin spray seat and main jet into the bottom of the carburetor housing.
5. Set the fuel level in the bowl by adjusting the fuel regulation screw. The standard setting is 2 turns, plus or minus a 1/4 turn.
6. Assemble the float valve, float and float pin to the bottom of the carburetor using the retainer pin.
7. Check the operation of the float and valve. All parts should move freely and not bind.
8. After assembling the float, check for proper fuel level using a small ruler or a float gage. The proper fuel level is 20.5mm (.807 in.).

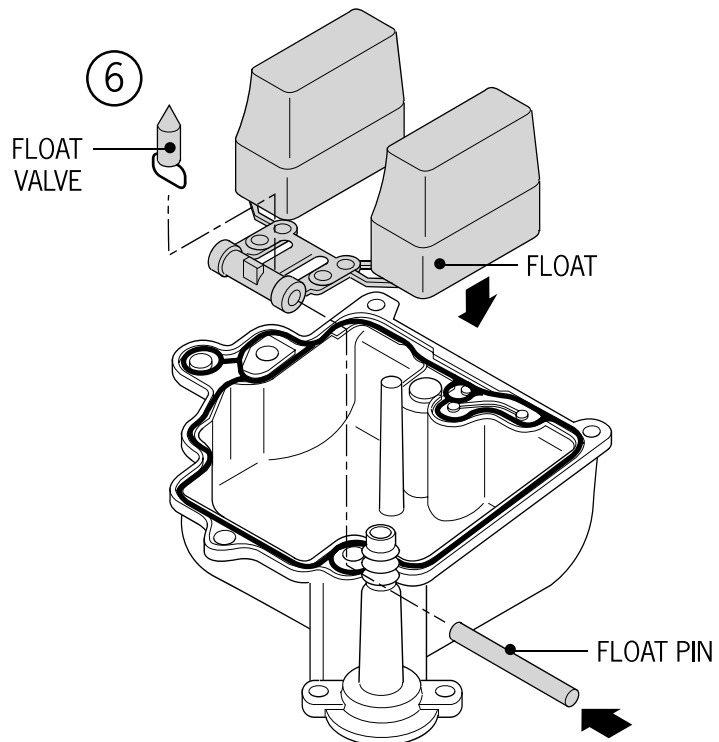
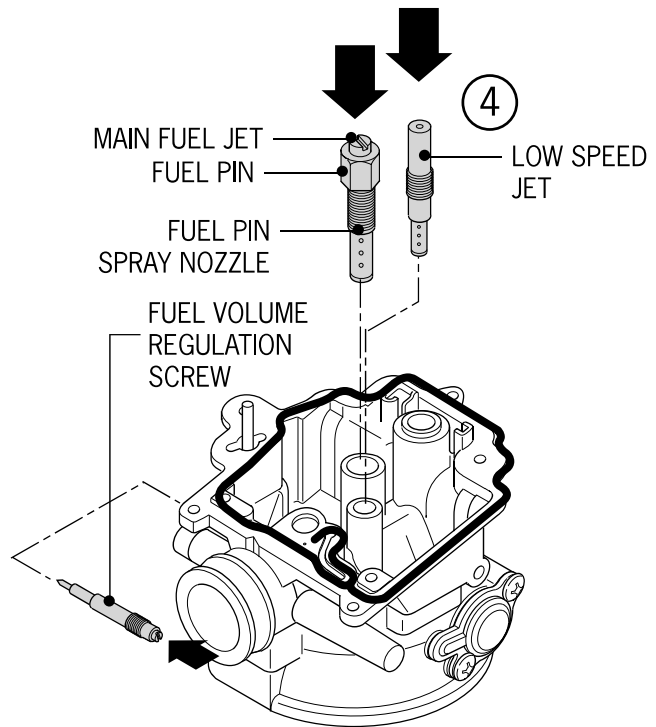

4. Fuel System

Accelerator Pump

1. Remove two screws on pump and take off cover.
2. Take off spring and acceleration pump plate.

Checking

1. Check acceleration pump plate for cracks or hardening of the rubber. Replace as necessary.
2. Check for blocked fuel passages.
3. Clean by high pressure air.
4. Reverse steps to reassemble.
5. Take special care with the accelerator pump plate to avoid damage.

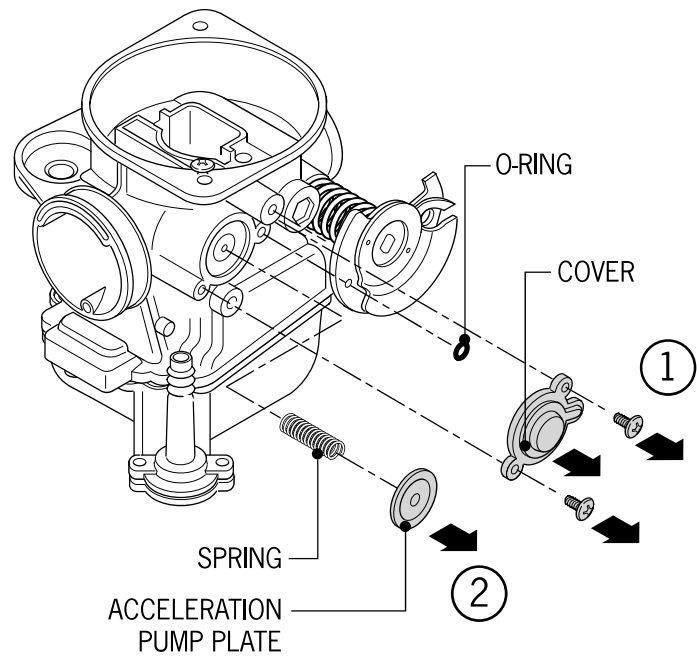

4. Fuel System

Assembly of Carburetor

1. Slide carburetor carefully into the manifold, making sure to align the tab on the manifold with the notch on the carburetor. Securely tighten the clamp screw to fix the carburetor in place. Do not over tighten the screws as this can cause damage to the manifold.

2. Attach the inlet pipe to the rear of the carburetor and tighten the clamp screw.

3. Attach the throttle cable to the throttle by installing the cable lug into the notch on the throttle plate. Insert the outer casing of the throttle cable into the cable support bracket. Make sure to align the "D" shape of the adjusting sleeve with the "D" shape hole of the bracket.

4. Use the adjusting nut and stop nut to set the cable tension. Correct adjustment should allow 1/4 inch of free play in the cable.

5. Attach the fuel line from the tank to the inlet on the carburetor and clamp securely.

6. Connect the wiring harness from the auto choke to the proper connection on the main wiring harness.

7. After starting the engine, set the idle speed using the idle adjusting screw.

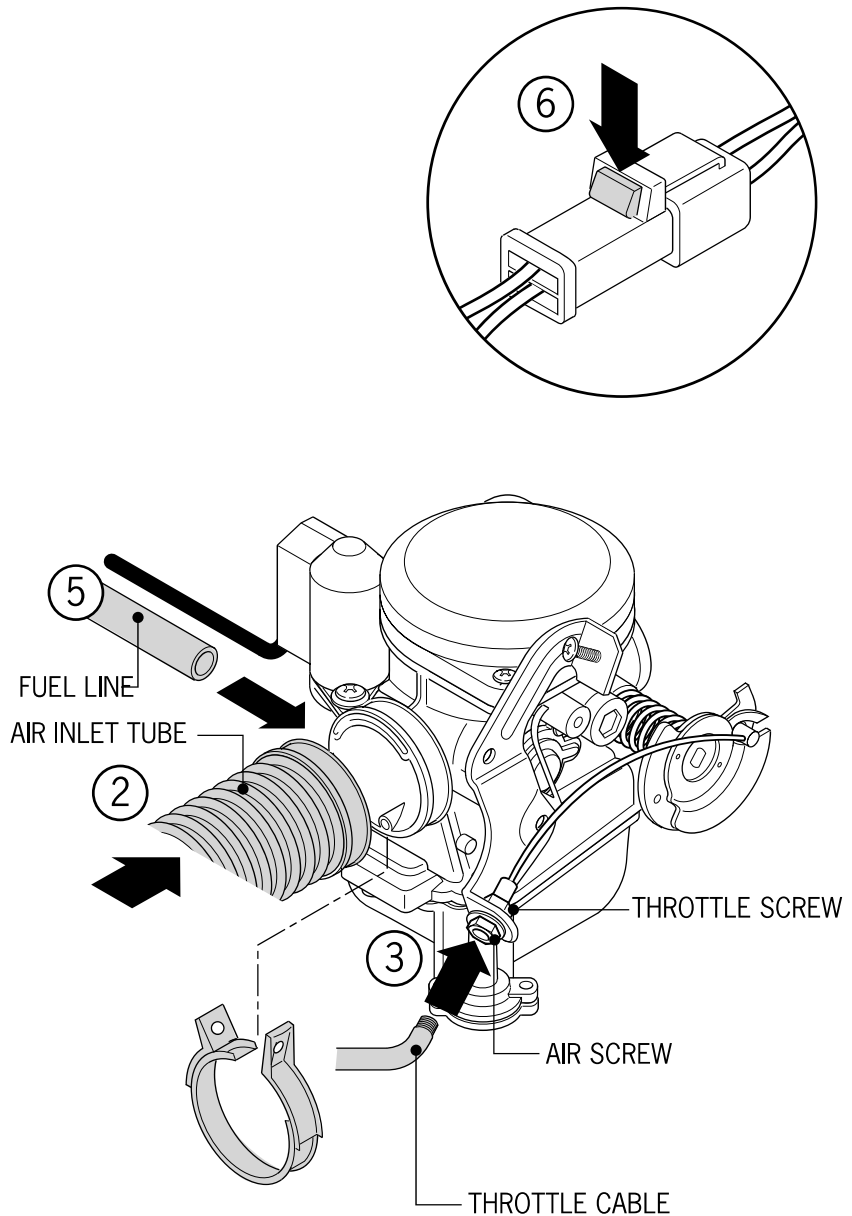

4. Fuel System

Carburetor Adjustment



It is generally not necessary to adjust the mixture screw on the side of the carburetor. This screw is preset at the factory and will have little effect on the performance of the carburetor.

1. If this screw has been removed for cleaning of the carburetor, it should be reset carefully. The standard setting is two turns out, plus or minus 1/4 turn.

2. To set this position, run the engine until warm and allow it to idle. Turn the screw in or out a little at a time and measure the idle RPM. The correct setting is achieved when the idle speed is maximized.

3. Adjust the idle speed of the engine once the engine has been warmed up.

4. Set the warm idle speed to 1900RPM, plus or minus 100RPM.

5. Check for engine return to idle speed after running at part throttle.

6. Make sure that the throttle cable allows the throttle control plate to return to the stop screw.

7. If needed, readjust the mixture screw to help stabilize idle performance.

NOTE: SOME COMPONENTS REMOVED FOR CLARITY.

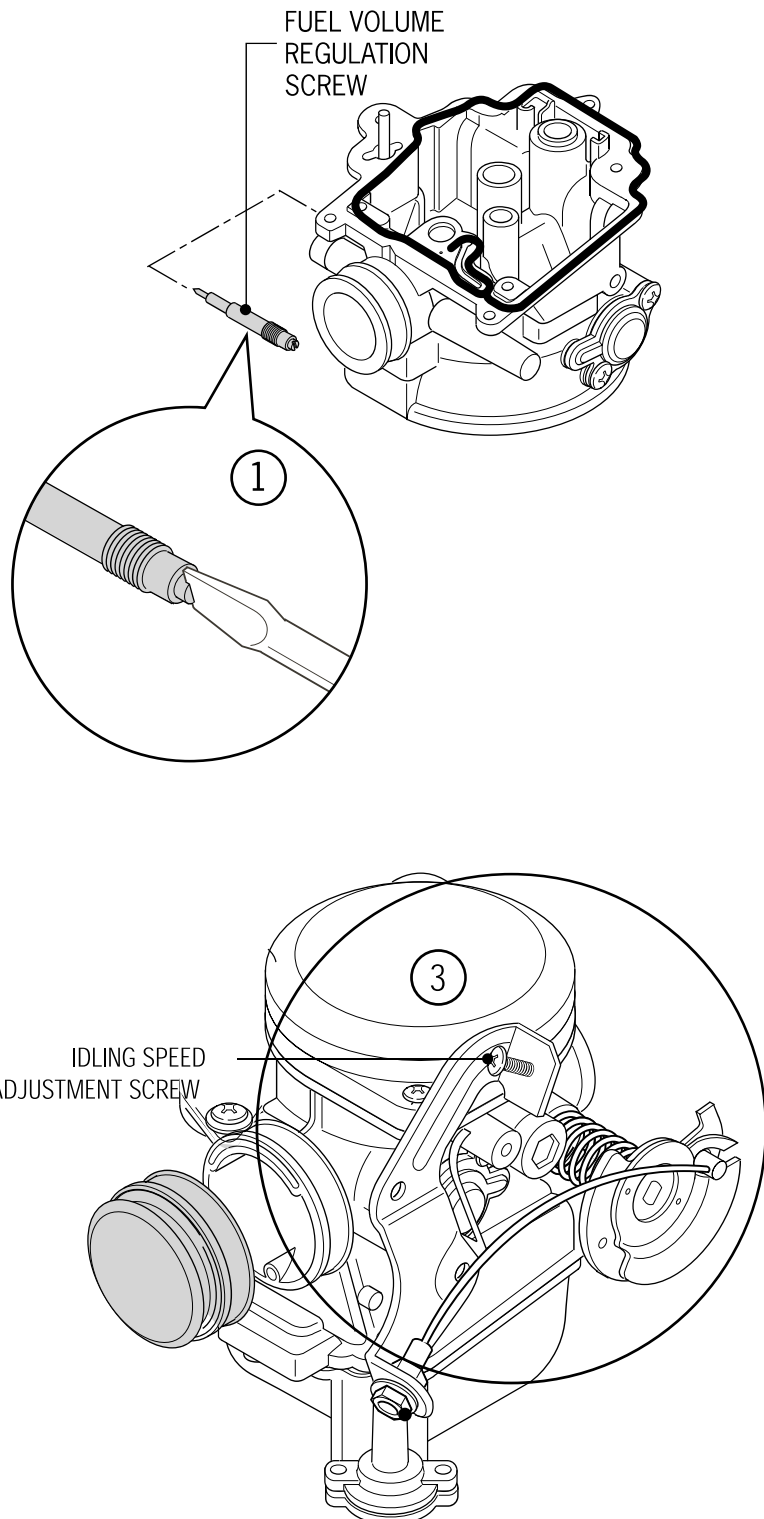

4. Fuel System

Automatic Fuel Valve

1. Disconnect the fuel line and the vacuum line from the control valve and from the carburetor and intake manifold. Carefully inspect these lines. Any blockage, deterioration, damage, or cracking of these lines can cause improper functioning of the fuel valve. Replace these lines as necessary.

2. Always make sure that the clamps work properly when replacing these lines in order to assure a tight seal of the lines at the fittings on the valve, carburetor and manifold.

3. To check the operation of the valve, apply a vacuum to the input fitting of the valve. Fuel should flow freely when the vacuum is applied and stop when it is removed.

4. Never attempt to clean the valve with high-pressure air. This will damage the valve and require replacement.

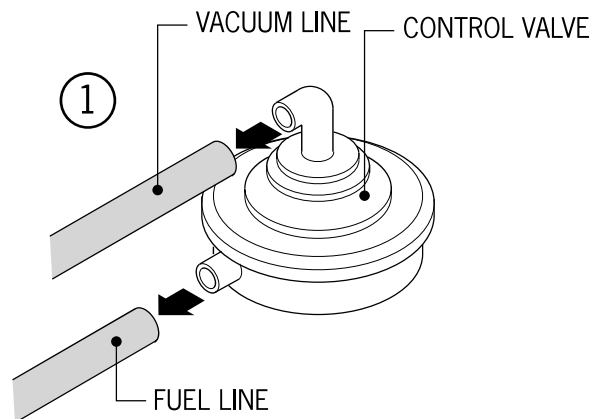

Fuel Meter Sending Unit

1. Disconnect the sending unit wiring harness.

2. Disconnect four mounting screws.

3. Lift and turn the sending arm to allow the float arm and float to be removed from the fuel tank. Take care not to bend or damage the float arm as this can cause improper readings.

4. Check the movement of the arm. It should move freely without binding or hesitation. Check the continuity of the coil. If it is open, the unit needs replacement. When reassembling the sending units, make sure that the gasket is not damaged to avoid leakage.

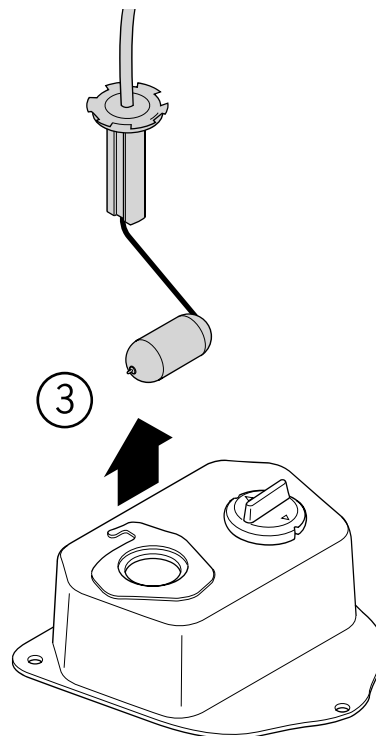

4. Fuel System

Air Filter Inspection

1. Remove air filter cover screws.

2. Remove cover.

3. Remove air filter element.

4. Remove clamp on air inlet tube.

5. Disconnect air tube from carburetor.

6. Remove air box. Make sure that the element is clean and free of dirt and oil. Excessive dirt and oil on the element can reduce engine performance.

7. During reassembly, make sure that the cover and tube connections are tight and do not leak. Air filter box leakage can reduce engine performance.

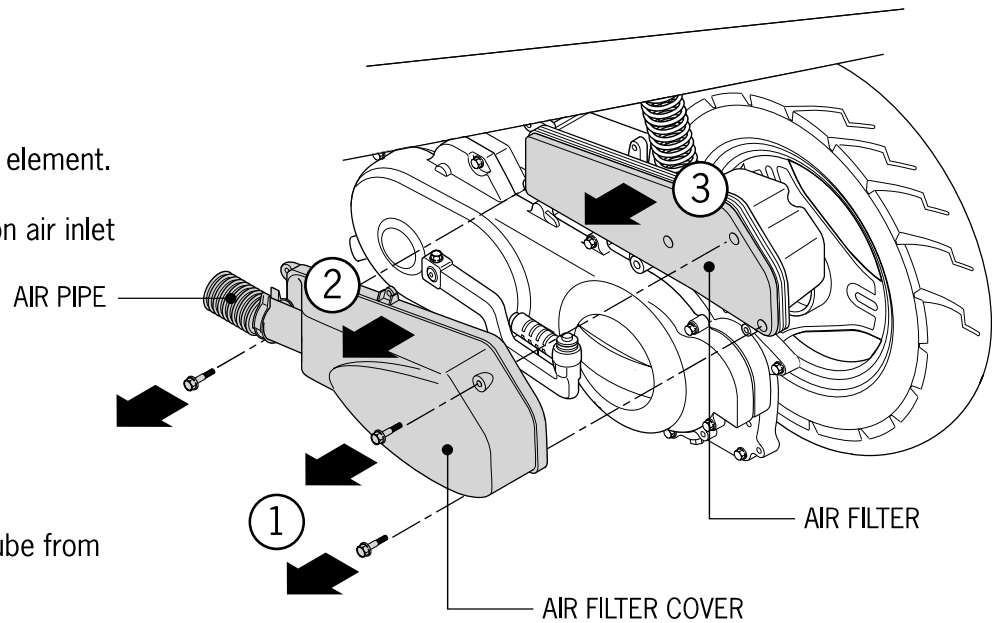

5. Cylinder Head Valve

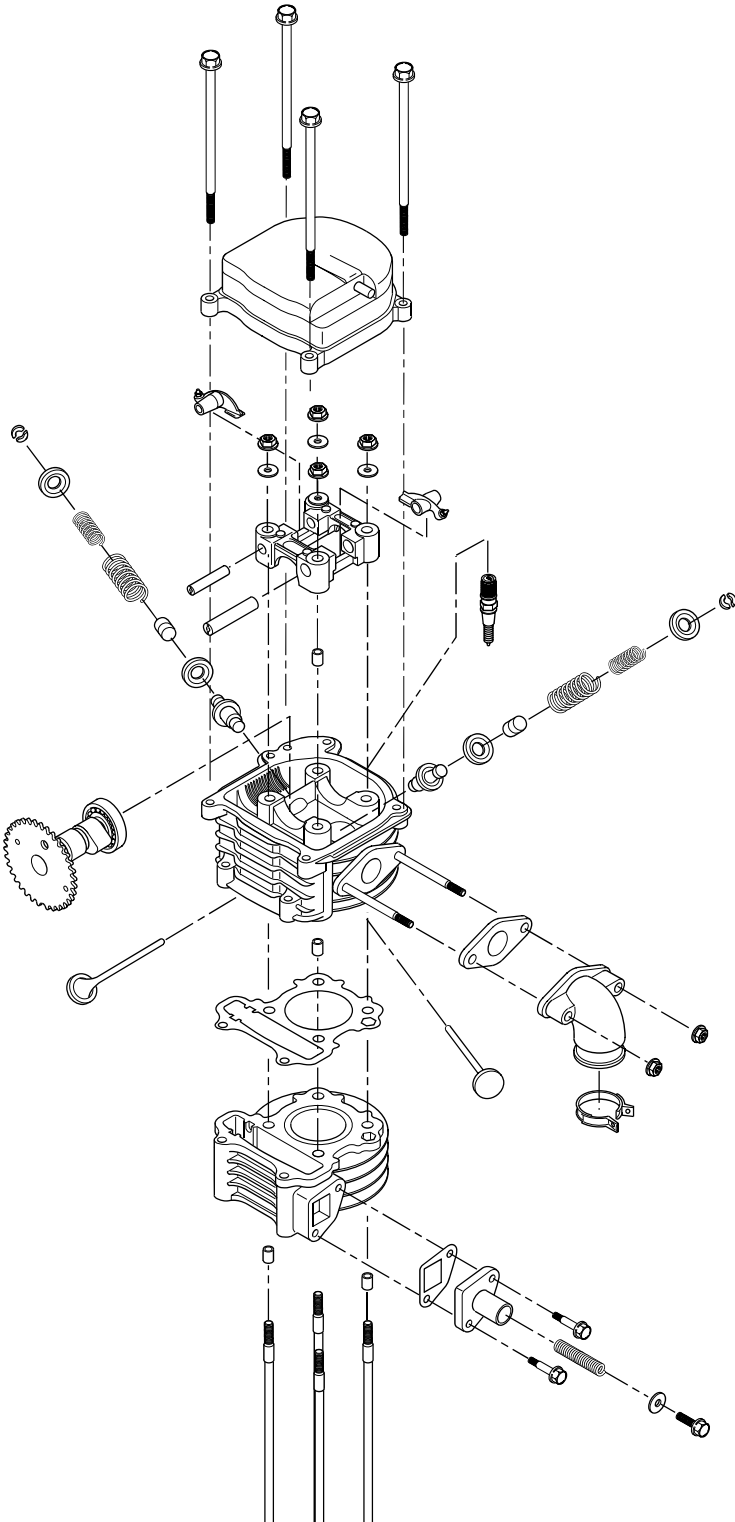

5. Cylinder Head Valve

Topic	Page	Topic	Page
Important information	7-2	Valve Seat Chamfer Cutting Tools	7-12
Trouble diagnosis	7-3	Valve Seat Cutting	7-12
Camshaft Disassembly	7-4	Building up of Cylinder Head	7-13
Checking of Camshaft	7-7	Installing Cylinder Head	7-14
Bearing Rocker Arm		Camshaft Assembly	7-15
Cylinder Head Disassembly	7-7	Camshaft Chain Regulator Assembling	7-16
Cylinder Head Break Down	7-9		
Checking Cylinder Head	7-9		
Valve and Valve Guide	7-10		

Important Information

- When working on the cylinder head and valve train, always use engine oil to lubricate sliding parts when assembling. Never assemble dry parts into the valve train.
- The camshaft is lubricated by engine oil supplied via an oil passage in the cylinder head. Make sure that this passage is clean and open when you reassemble the head.

- When measuring parts to determine wear, wash the parts with solvent and dry them in order to get accurate measurements.
- When disassembling the valve components, keep them in order and reinstall them in the reverse order.

Item		Standard valve	Used Limit
Valve gap (cold)	IN	(0.04) 0.05	—
	EX	(0.04) 0.05	—
Cylinder head compressed pressure		15kg/cm ² -600rpm	—
Cylinder head surface twisting			0.05
Camshaft cover angle height	IN	25,761	25.681
	EX	25,604	25.24
Valve rocker arm inner diameter	IN	10,000-10.015	10.10
	EX	10,000-10.015	10.10
Valve rocker arm bearing outer diameter	IN	9,972-9,987	9.91
	EX	9,972-9,987	9.91
Valve seat angle	IN	1.0	1.8
	EX	1.0	1.8
Valve bar outer diameter	IN	4,975-4,900	4.9
	EX	4,955-4,970	4.9
Valve guide pipe inner diameter	IN	5,000-5,012	5.3
	EX	5,000-5,012	5.3
Gap between valve bar and guide pipe	IN	0.010-0.037	0.08
	EX	0.030-0.057	0.10
Valve spring	Inner spring	29.1	26.1
	Outer spring	33.5	30.5

5. Cylinder Head Valve

Torque Value

- Camshaft bolt 16 ft lbs
- Lubricate threads with oil
- Valve gap adjusting screw cap 7 ft lbs



General tools

- Valve spring compressor
- 45 degrees IN/EX
- Valve seat reamer 24.5mm
- Plane reamer 30 degrees IN
- Valve seat reamer 25mm
- Plane reamer 32 degrees EX
- Valve seat reamer 22mm
- Plane reamer 60 degrees IN/EX
- Valve seat reamer 26mm
- Reamer damping fixture 5mm



Special tools

- Valve spring compressor accessories
- Valve gap regulatory spanner
- Valve guide screwdriver
- Valve guide reamer

Trouble Diagnosis

- Confirm poor operation of cylinder head by measuring pressure or by noise produced by engine upper end.

Slow Speed Hitch

- Compression pressure too low
- Bad valve gap
- Burning or curving of valve
- Bad valve timing
- Broken valve spring
- Bad valve seat
- Leakage of cylinder head gasket
- Warped cylinder head surface or cracking
- Bad spark plug

Compression Pressure Too High

- Too much carbon buildup in combustion chamber

White Smoke from Exhaust Pipe

- Wearing of valve guide
- Broken oil seal

Abnormal Noise

- Bad valve gap
- Broken or burning of valve or valve spring
- Wearing and breaking of camshaft
- Wearing of inner chain adjusting plate
- Wearing of cam shaft and valve rocker arm

5. Cylinder Head Valve

Disassembling of Camshaft

1. Disassemble middle cover. (2-2)
2. Remove four bolts and two nuts, take off valve cover.
3. Disassemble cam chair adjusting bolt and spring.
4. Use the kick-start lever to slowly turn engine until "T" mark on flywheel lines up with indicator on crankcase. Check position of camshaft to find if both valves are closed. The hole in the cam gear should be away from the engine. If this is not correct, rotate the crank one revolution to achieve this alignment.
5. Remove four bolts and remove camshaft caps.

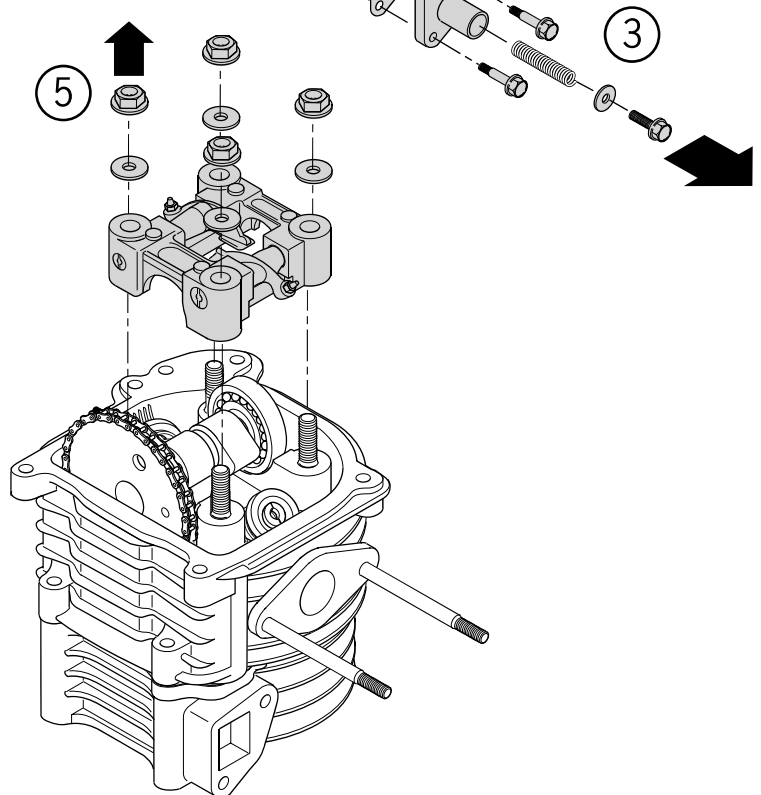
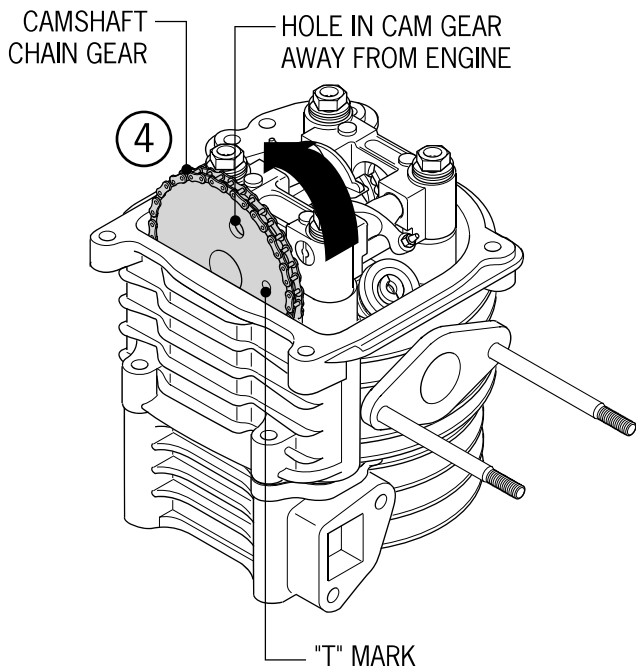
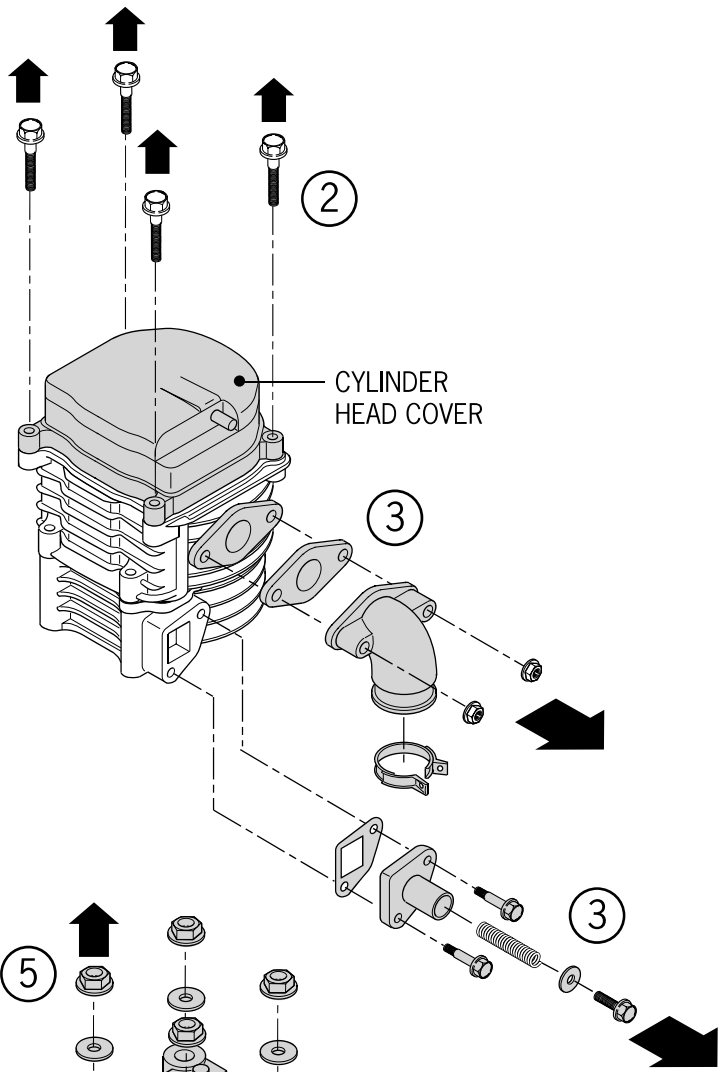

5. Cylinder Head Valve

6. Remove rocker arms and pivots.
7. Remove camshaft gear from camshaft chain.
8. Remove camshaft.
9. Check Camshaft
10. Check cam lift.
 - Use limit: IN: 25.681mm below change
 - EX: 25.524mm below change
11. Check surface of cam lobes for weary surface breakdown, scuffing or cracking.
12. Check camshaft and bearing for loose fit or damage.
13. If any excessive wear or damage is found, replace the camshaft.

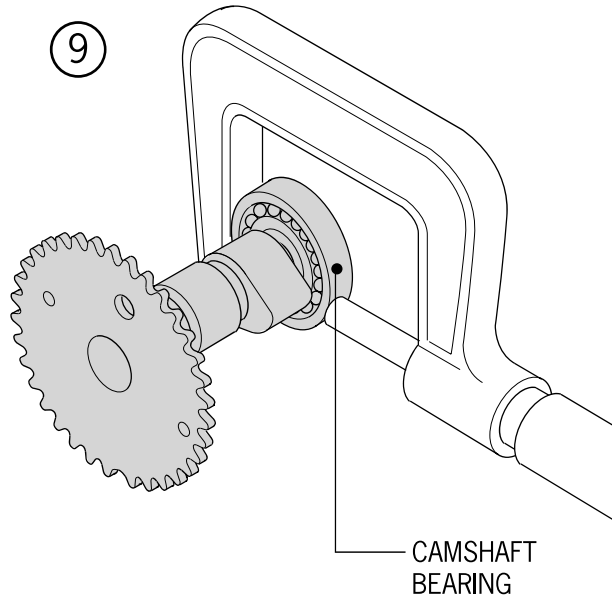
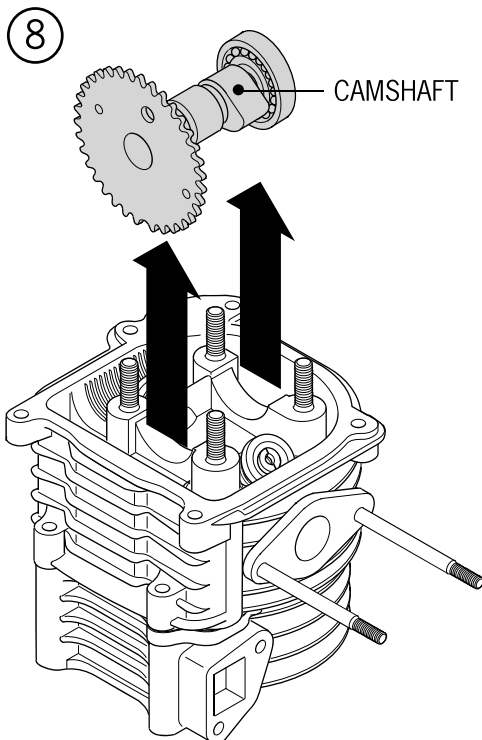
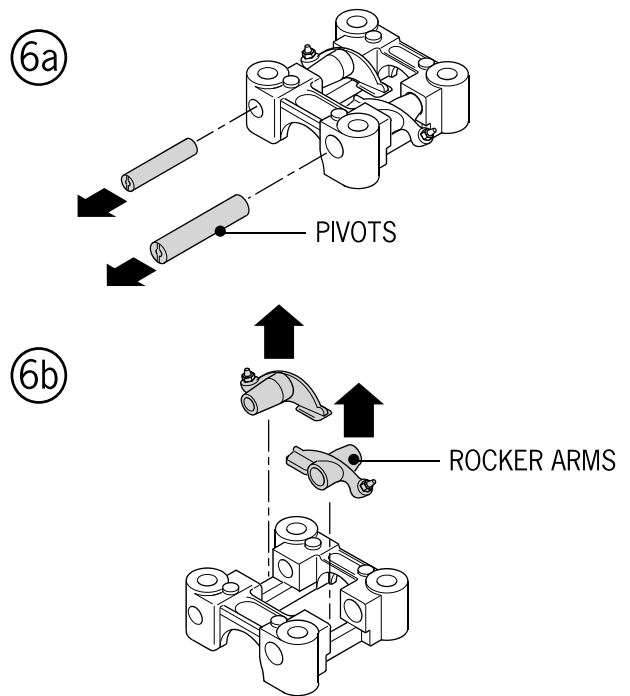

5. Cylinder Head Valve

Checking of Camshaft Bearing Rocker Arm

1. Check if camshaft bearing fixed seat and camshaft rocker arm and camshaft rocker bearing is worn or broken.

2. Measure outer diameter of camshaft bearing fixed seat and camshaft rocker arm. Used limit: 9.91mm (.390 in.). Change if worn larger.

- Inner diameter of camshaft rocker arm. Used limit: 10.10mm (.398 in.). Change if worn larger.

- Outer diameter of camshaft rocker arm bearing and camshaft rocker arm. Used limit: 9.91mm (.390 in.). Change if worn larger.

- The gap between camshaft rocker arm and camshaft rocker arm bearing.

Used limit: 0.10mm (.004 in.). Change if worn larger.

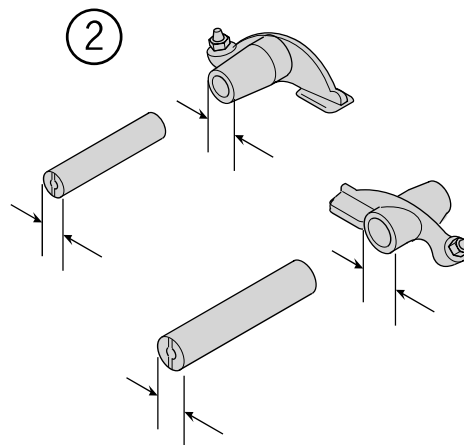
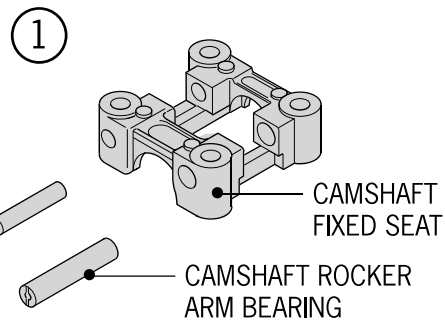

Disassembly of Cylinder Head

1. Remove camshaft bearing. (7-4)
2. Remove carburetor (5-4)
3. Remove exhaust pipe. (2-4)
3. Remove inlet manifold.

5. Cylinder Head Valve

4. Remove fan cover.
5. Remove bolt and screw of engine cover.
6. Disassemble and remove engine cover.
7. Pull up on cylinder head to break gasket and slide off cylinder stands.
8. Take off location pin and cylinder head gasket.
9. Take off camshaft chain guide bar.

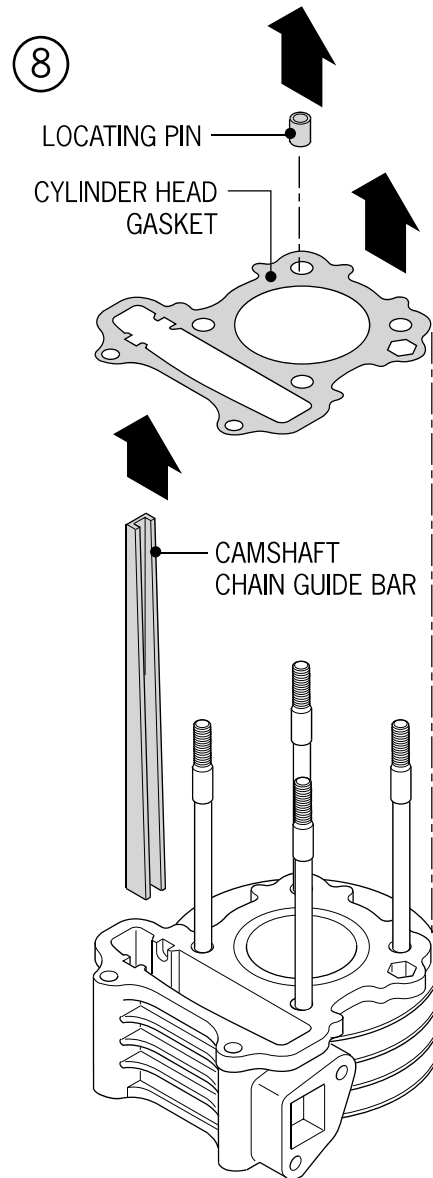
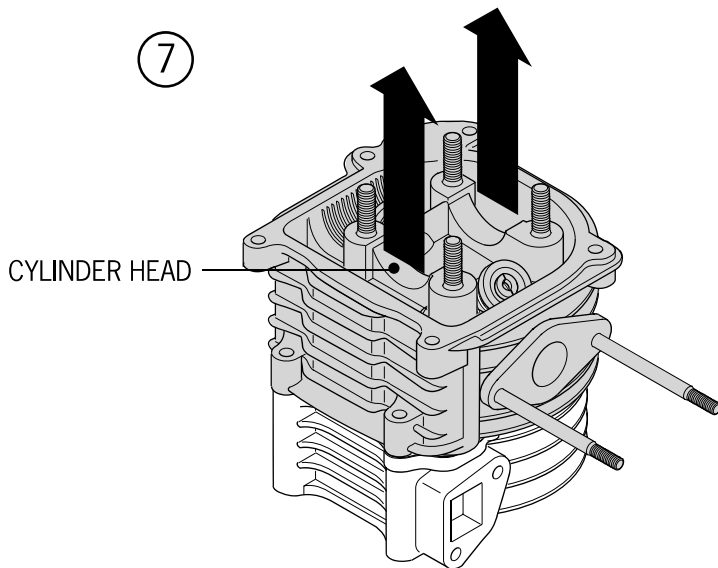

5. Cylinder Head Valve

Breaking Down of Cylinder Head

1. Use valve spring compressor to take off lock clip and supporter and valve spring, spring seat valve.

⦿ Place parts in sequence after disassembling and assemble in reverse order during reassembly.

2. Clean carbon deposits from combustion chamber.

3. Remove gasket material on cylinder head surface.

⦿ Don't damage cylinder head sealing surface.

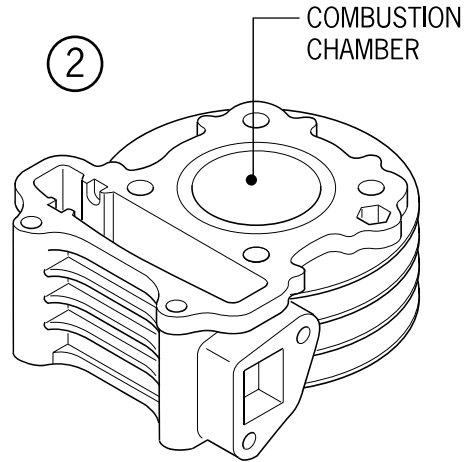
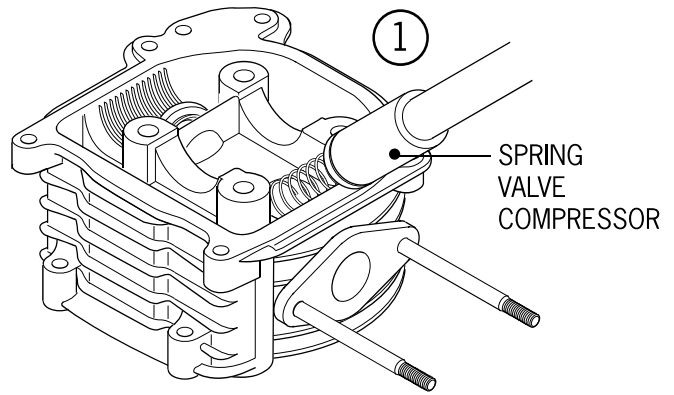

Checking Cylinder Head

1. Check spark plug hole for damage.

2. Check valve spring seats for alignment.

Used limit: 0.05mm (.002 in.) above align
•Measure length of inner and outer springs.

Used limit:

•Change if inner spring below 26.1mm (1.03 in.).

•Change if outer spring is below 30.5mm (1.2 in.).

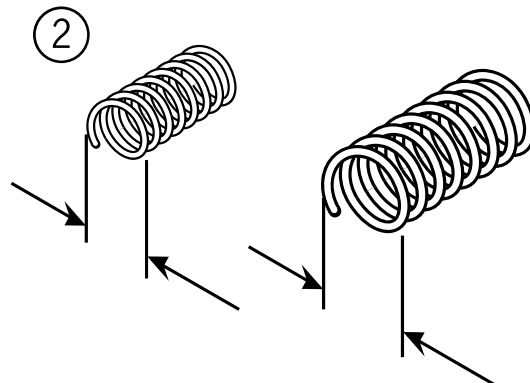

5. Cylinder Head Valve

Valve and Valve Guide

1. Check if valve is beat, burnt or broken.
2. Check if valve and valve guide are blocked.
3. Measure every valve stem's outer diameter.
 - Used limit: Change if below 4.9mm.

 Remove carbon deposits from valve guide using a reamer.



 Rotate reamer in proper direction and do not stop rotation to push in or pull out.

4. Measure inner diameter of every valve guide.

Used limit:

IN: Change if above 5.3mm.

EX: Change if above 5.3mm.

Valve guide replacement

1. Operate cylinder at the temperature of about 100°C-15°C 212°F.

 Heat cylinder head quickly and evenly to prevent warping.

2. Press, cut or pry out the valve guide.

 Be careful to not damage cylinder head surface.

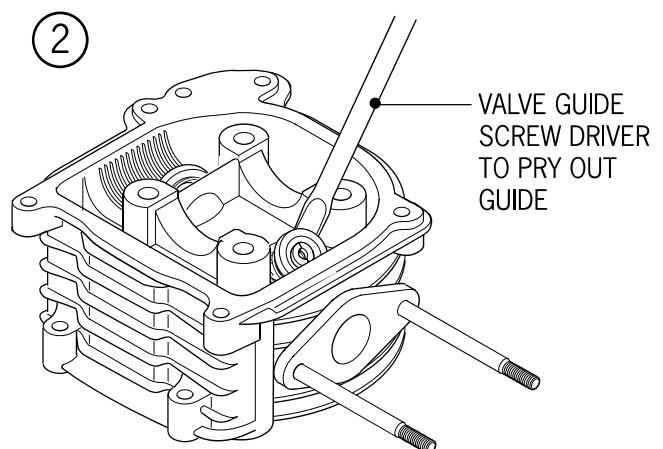
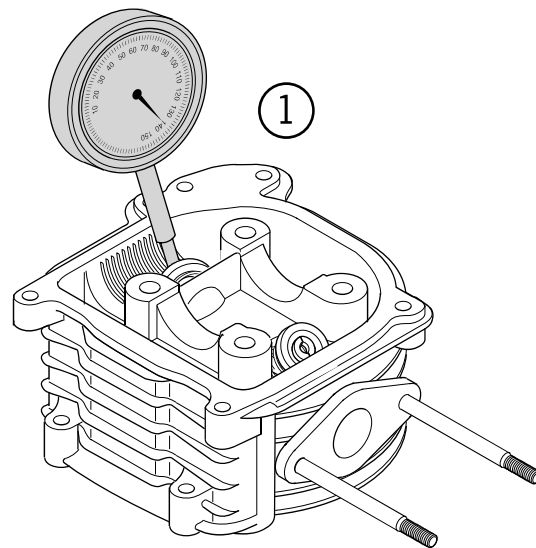
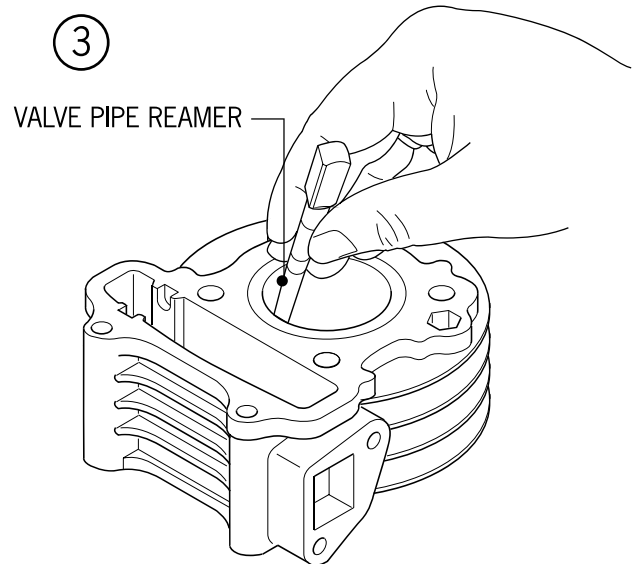

5. Cylinder Head Valve

3. Press in the new valve guide. Spread engine oil on new o-ring and build up new valve guide pipe. Make sure cylinder head is still warm when pressing in new guides.

4. Size valve guide with reamer after installing.

⊙ Use cutting oil on reamer. Rotate reamer in proper direction and do not stop rotation to punch in or pull out.

5. Clean cylinder head and get rid of cut bits of metal and dust.



Special tools

- Valve guide pipe reamer
- Valve Seat Checking and Correcting
- Valve Seat Checking

6. Remove carbon deposit from combustion chamber valves.

7. Spread emery on seat surface between valve and valve seat. Use polishing bar to wear in valve.

8. Take out valve and check valve seat surface. Change if valve surface is coarse or facial polished.

*Valve seat surface width checking
Used limit: above 1.8mm (.07 in.) correct.*

9. Correct valve seat with chamfered tool if surface width is not even, too wide or too narrow.

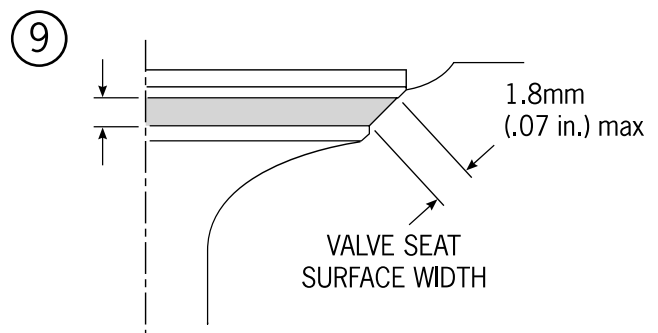
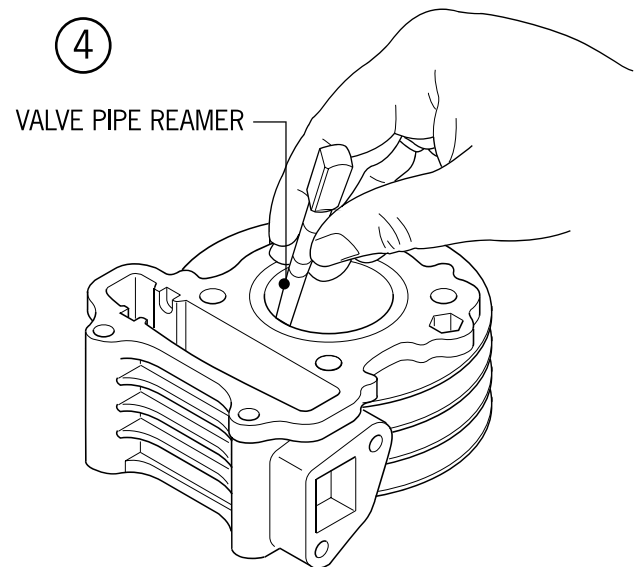
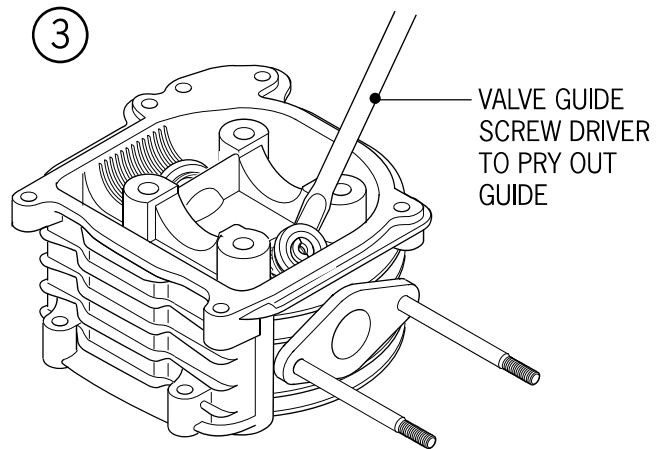

5. Cylinder Head Valve

Valve Seat Chamfer Cutting Tools

Refer to valve chamfered tool handbook for details.

1. Press and rotate with 4-5kg 10-12 lb force to polish and cut when correcting.

🌀 Use chamfered tool after spreading engine oil on it.

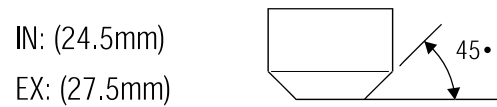
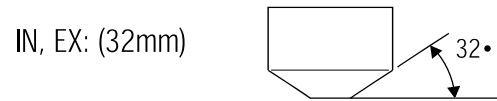
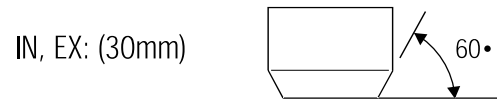

Valve Seat Cutting

1. Do not polish or cut excessively.
2. Cut primary surface with 450 cutting head.
3. Chamfer inner edge with 320 cutting head.
4. Correct inner surface by sixty-degree chamfered tool.

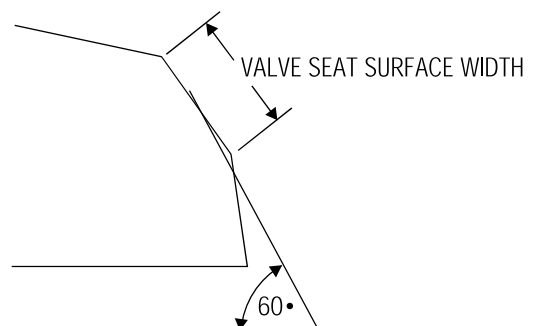
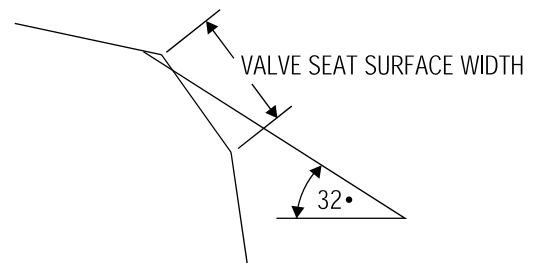
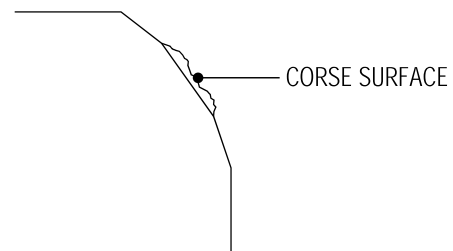

5. Cylinder Head Valve

5. Trim valve seat to assigned seat width and valve seat width with 45 degree chamfered cutting tool.

Standard valve: 1.0 mm (.393 in.)
Check contact place of valve seat.

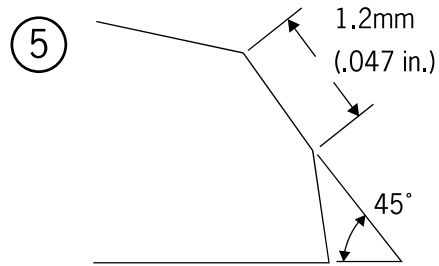

6. Polish with 30-degree chamfered cutting tool if the contact place is too high. Trim to assigned width with 45-degree chamfered cutting tool. Polish valve contact surface with emery and polishing bar after correcting bar.

CONTACT PLACE TOO HIGH

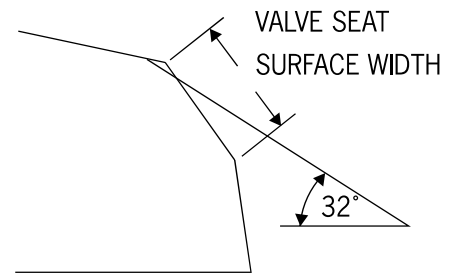
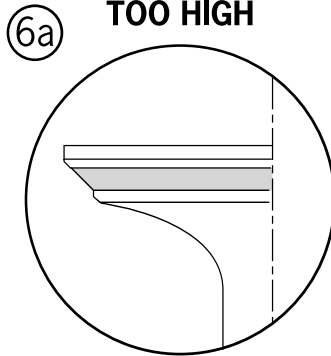

7. Wash and clean cylinder and valve after polishing and grinding.

 Rotate and press softly when polishing. Don't put emery into valve and valve guide pipe when polishing.

CONTACT PLACE TOO LOW

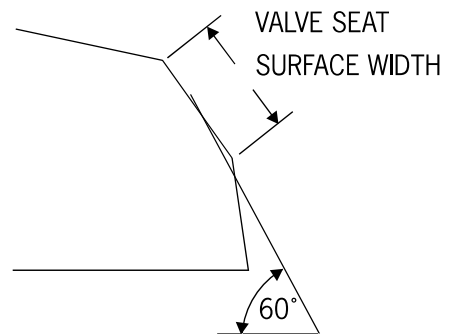
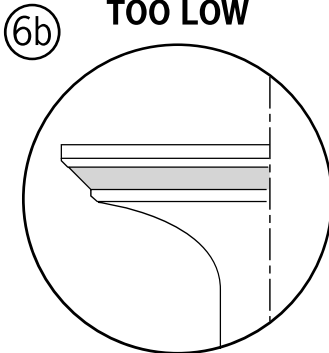

8. Spread red ink on 45-degree seat surface and confirm if the center of the contact surface of the valve is even after correction.

Building Up of Cylinder Head

1. Build Up Spring Seat

 Use new oil seals when reassembling.

2. Spread engine oil on valve stem and put into valve guide.

3. Build up inner and outer valve spring and put in valve collar using spring compressor.

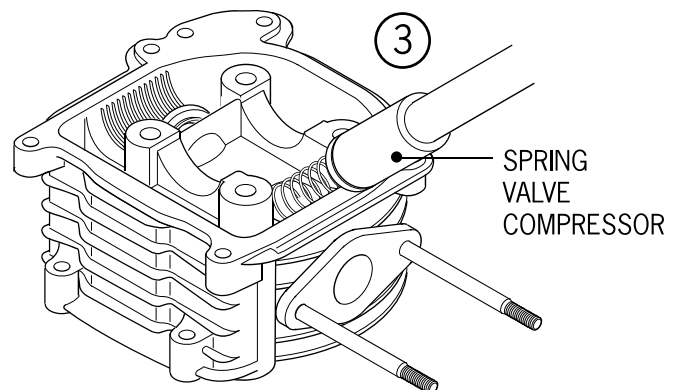

5. Cylinder Head Valve

4. Use valve spring compressor accessory to make valve contact with valve collar. Tap with plastic mallet two or three times, softly, on the ends of the valve to seat collars.

⊙ When using mallet, be careful to not damage valves.

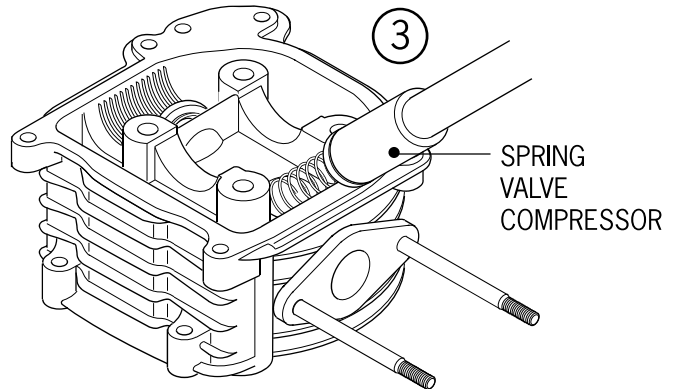

Installing Cylinder Head

1. Install locating pin and gasket.
2. Install cam chain adjuster plate.
3. Slide cylinder head over studs and into place.

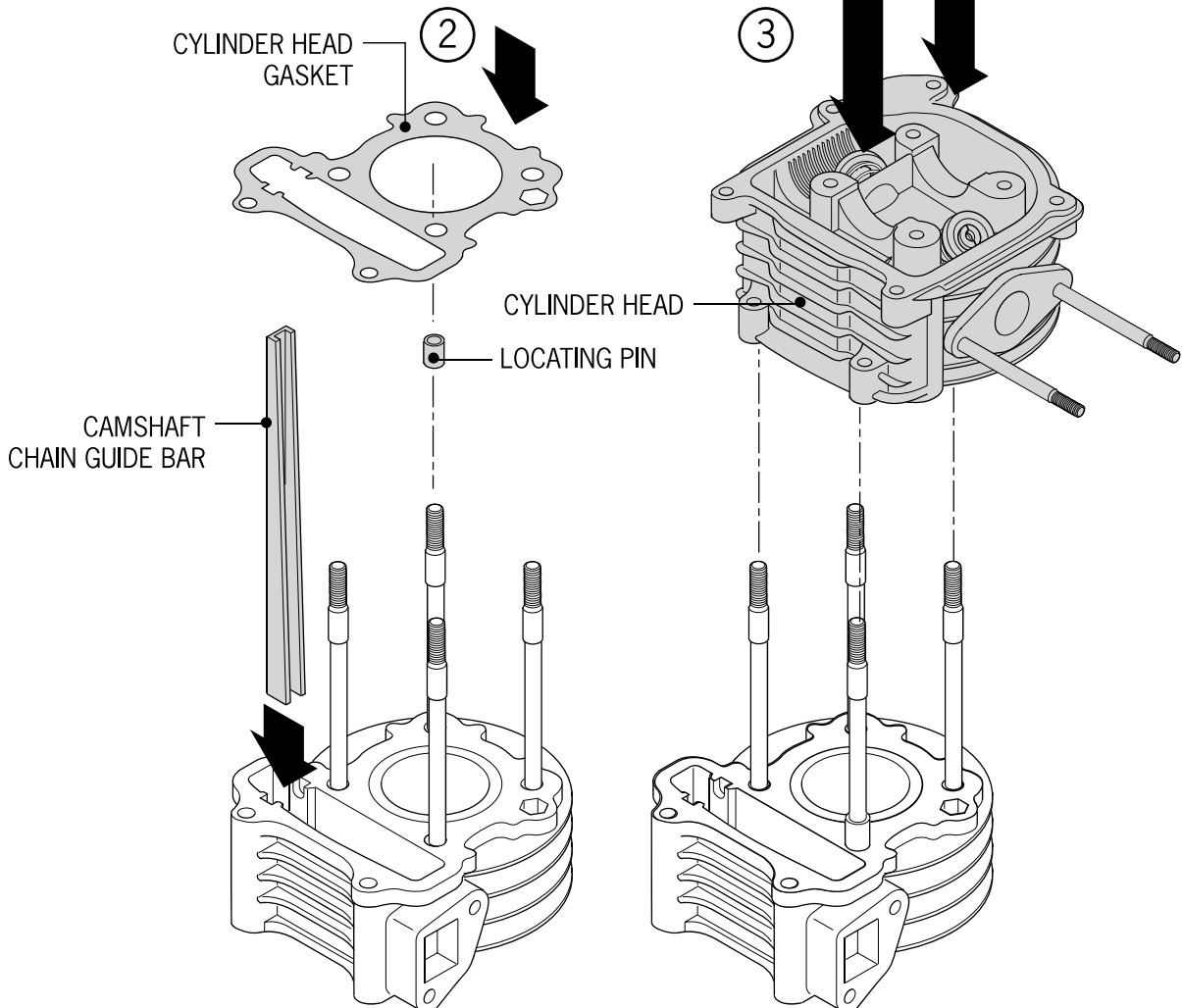

5. Cylinder Head Valve

Camshaft Assembly

1. Assemble rocker arm and rocker shaft.

 Make alignment between shaft end and fixed screw bolt hole of camshaft seat when valve rocker shaft is assembled.

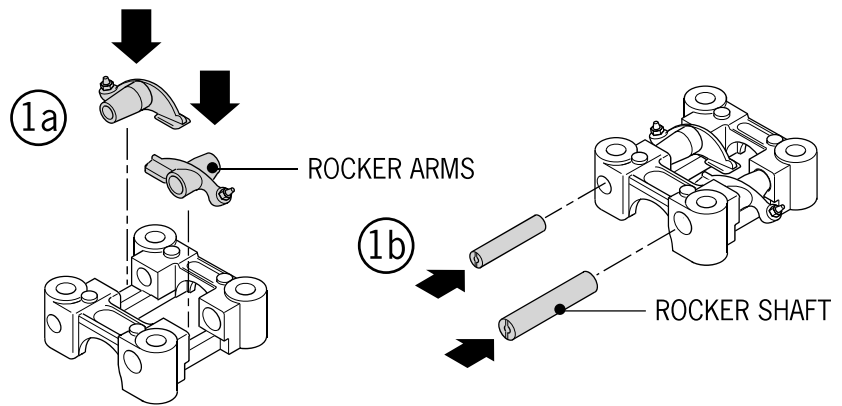

2. Install the camshaft into the cylinder head. Seat the camshaft into the fixed seat and check alignment.

3. Install camshaft fixed seat.

4. Rotate flywheel and align "T" mark on flywheel with crankshaft mark.

5. Align the camshaft chain gear round hole away from engine.

6. Install camshaft chain on camshaft gear.

7. Assemble fixed studs.

8. Assemble camshaft seat, spacer and nut into cylinder head. Tighten cylinder head nut and bolt securely.

*Torque valve:
Camshaft fixed nut:
2.0kg-m 15 ft lbs*

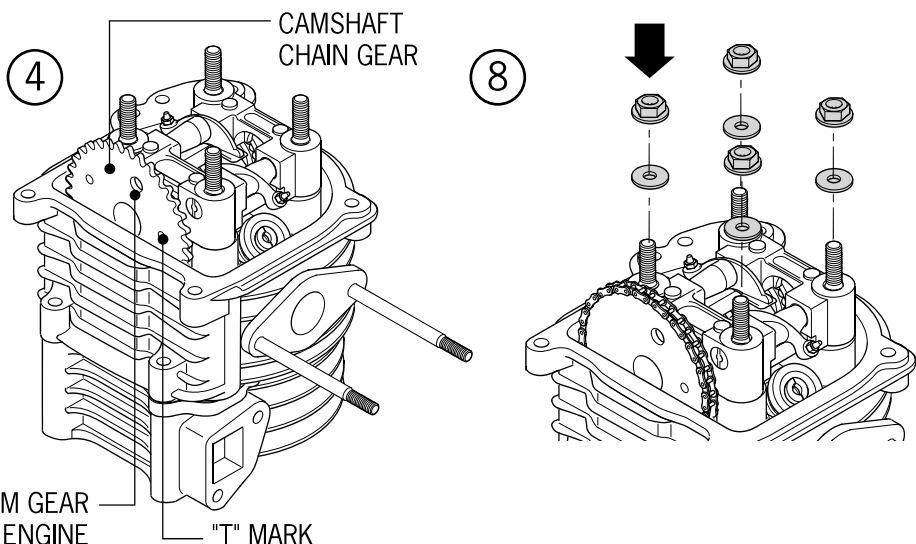
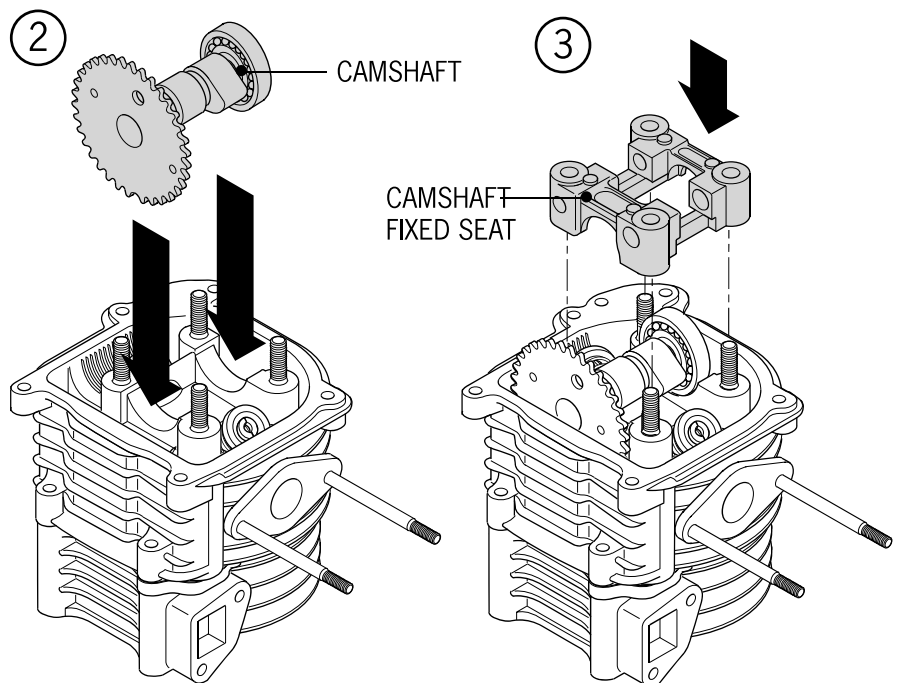

5. Cylinder Head Valve

Camshaft Chain Regulator Assembling

1. First, build up camshaft chain regulator and spacer. Second, lock two fixed bolts. Third, put spring into camshaft chain regulator. Last, assemble the o-ring and fixed bolt.

- Press down regulator master jaw and drive down driving bar when camshaft chain regulator is assembled.

Torsion valve: 0.3-0.5 kg-m
Regulate valve gap: (3-5)

2. Change the ring of he cylinder head cover and assemble the cylinder head cover.

- Put o-ring into furrow.

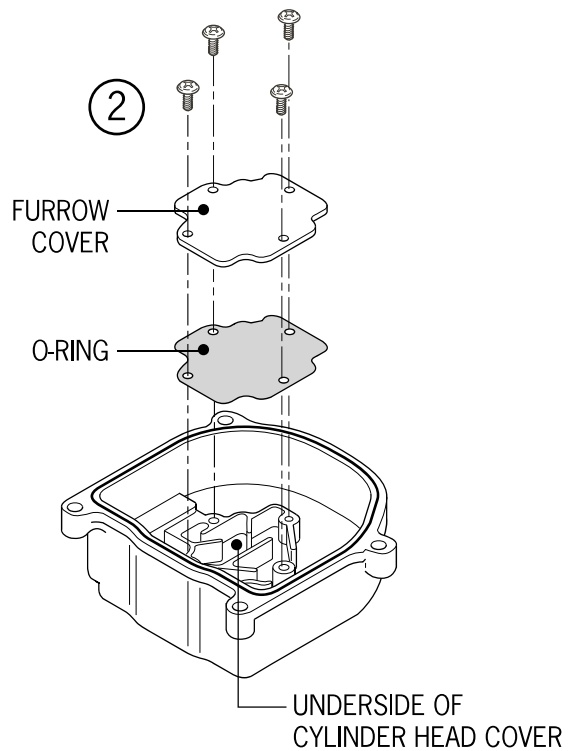
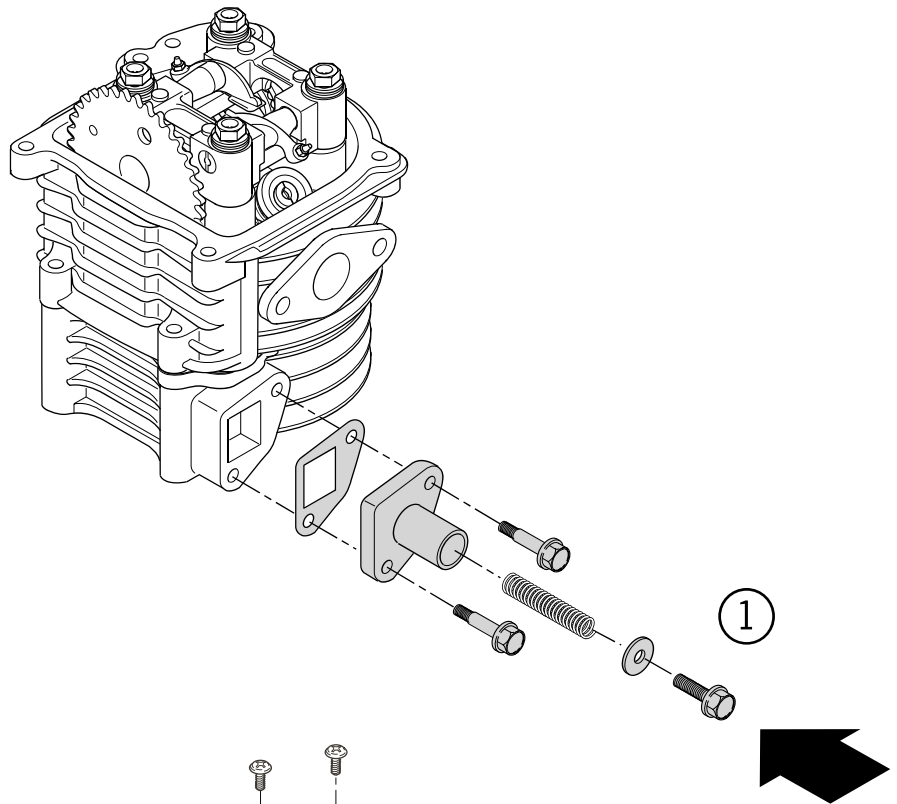

5. Cylinder Head Valve

3. Lock fixed screw bolt of cylinder head cover.

Torsion valve: 0.8-1.2 kg-m

4. Spread grease on threading position of camshaft fixed seat screw bolt.

5. Lock two or three times at diagonal of camshaft fixed seat screw cap.

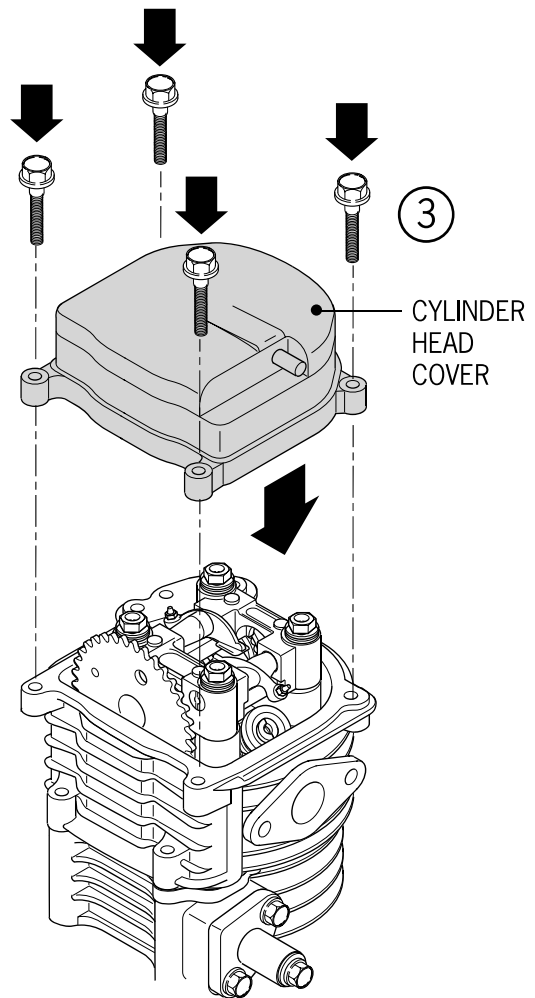

6. Cylinder and Piston

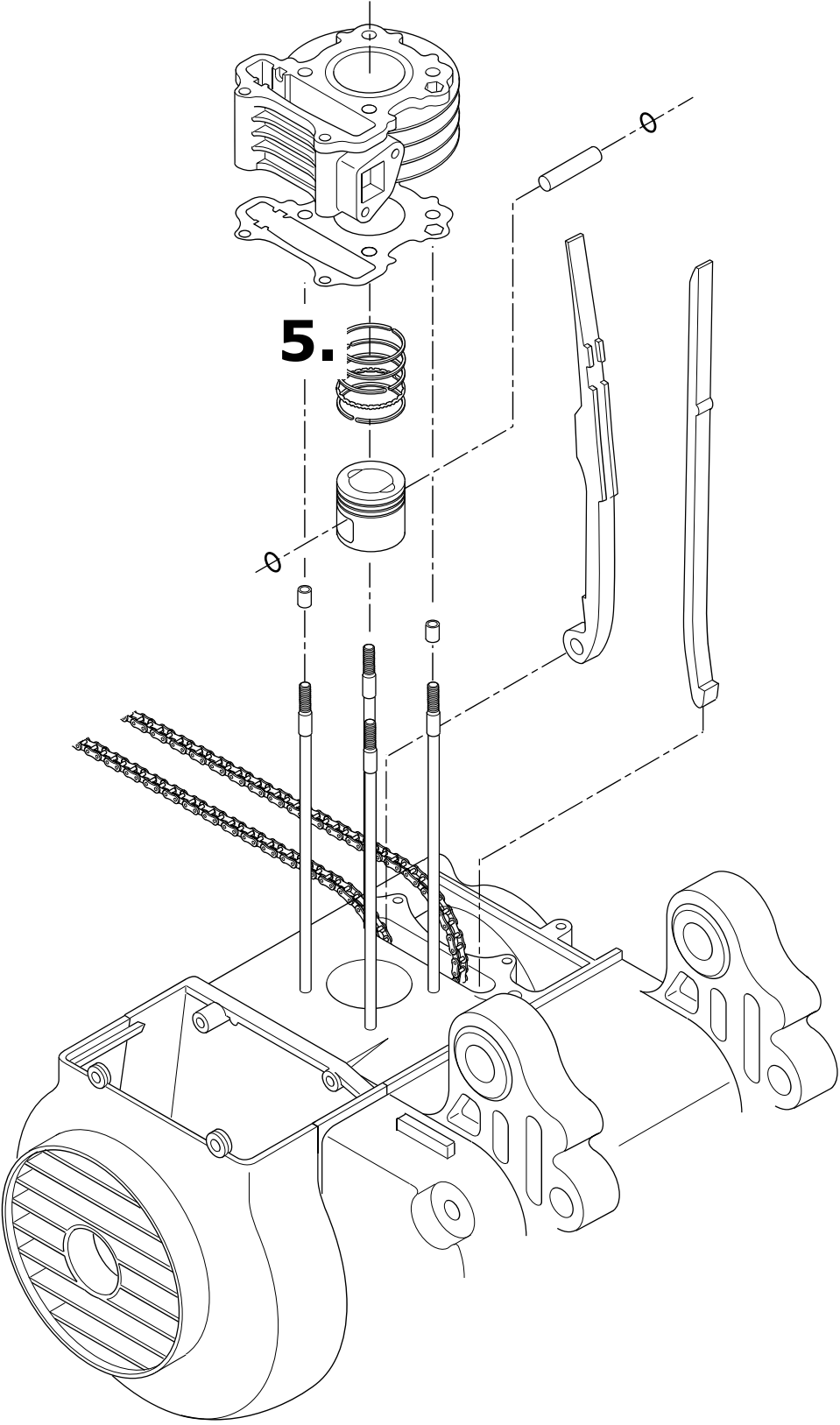

6. Cylinder and Piston

Topic	Page	Topic	Page
Material	8-2	Removing the piston	8-3
Troubleshooting	8-2	Assembling the piston	8-7
Removing the cylinder	8-3	Assembling the cylinder	8-8
Checking the Cylinder	8-5		

Important Points

- The work on the cylinder and piston can be done on the engine without complete disassembly.
- After taking them apart, clean and dry the cylinder and piston with the compressed air before measuring and testing.
unit: mm

Item		Normal size	Max. Service Allowance
Cylinder	ID	(0.04) 0.05	39.10
	Distortion	—	0.05
	Cylindricity	—	0.05
	Out-of-roundness	—	0.05
Piston	Clearance between the ring and the ring groove	0.015-0.055	0.09
		0.015-0.055	0.09
	Compressed gap	0.08-0.20	0.45
		0.05-0.20	0.45
		0.20-0.70	—
Piston ring	OD of piston	38.980-38.780	38.7
	Check point of OD	9mm away from skirt	—
	Clearance between piston and cylinder	0.010-0.040	0.1
	ID of the piston pin hole	13.002-13.008	13.04
OD of the piston pin		12.994-13.000	12.96
Clearance between the piston pin and the hole		0.002-0.014	0.02
ID of the small end of the connecting rod		13.016-13.034	13.06

Troubleshooting

- In case of difficulty starting or unsteady running at low speeds, check if there is white smoke coming out of the air hole pipe of the crankcase. If that is the case, the piston ring is worn, burnt or broken.

Low Compression Pressure

- The piston ring is worn, burnt or broken.
- The piston/cylinder is worn or damaged.

Compression Pressure is Too High

- Carbon deposits on the piston and the combustion chamber.

White Smoke Coming Out of the Exhaust Pipe

- The piston ring is worn or damaged.
- The piston/cylinder is worn or damaged.

Knocking Noise by the Piston

- The cylinder, the piston or the piston ring is worn.
- The piston pin and its hole are worn.

6. Cylinder and Piston

Removing the Cylinder

1. Detach the cylinder head (refer to 7-6).
2. Remove the chain guide of the cam chain.
3. Remove the cylinder.
4. Remove the cylinder gasket and the locating pin from the top of the cylinder and the base of the cylinder.

Removing the Piston

1. Remove the piston pin snap ring.



Attention:

Don't drop the snap ring into the crankcase.

2. Take out the piston pin and then the piston.
3. Push the piston pin from the side opposite the removed snap ring.
4. Use a small punch or drift pin if necessary and tap gently with a soft-faced mallet.



Use caution to keep from scratching the piston surfaces.

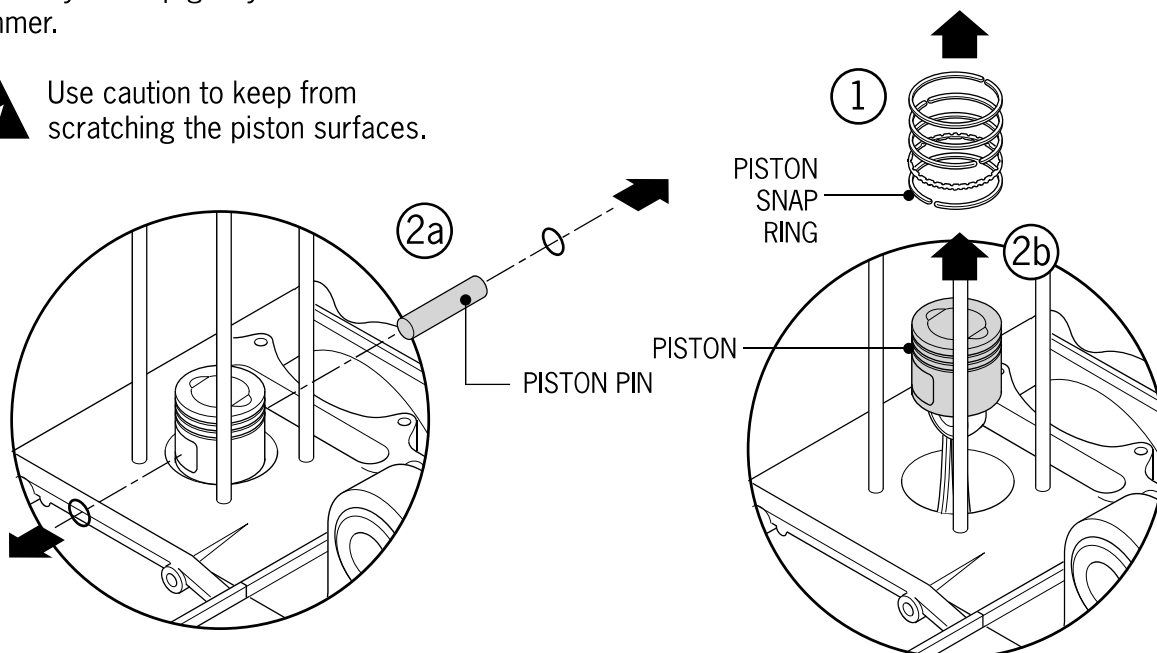
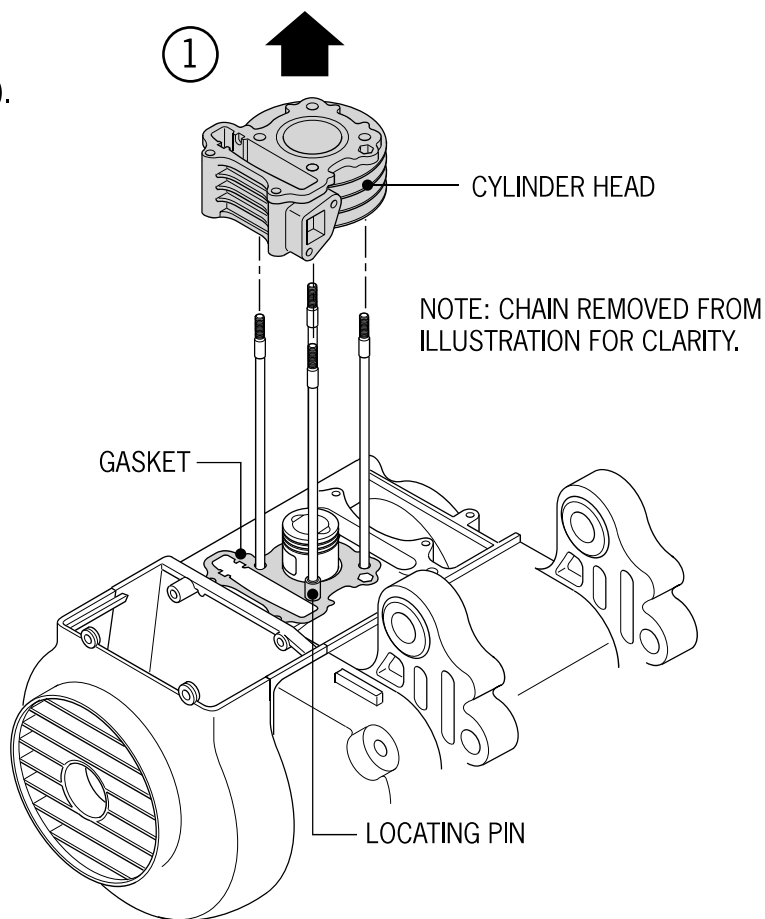

6. Cylinder and Piston

Checking the piston, the piston pin and the piston ring.

⦿ Attention:
Don't damage or break the ring.

1. Remove all of the carbon deposits from the ring groove.

2. Mount the ring and measure the clearance of the ring groove.

Maximum service allowance:
The top ring: Replace when it goes beyond 0.09mm (.035 in.).

The second ring: Replace when it goes beyond 0.09mm (.035 in.).

3. Remove the piston rings.
Install the piston rings into the bottom of the cylinder.

⦿ Attention:
Use the piston head to press the rings into place in the cylinder.

4. Measure the piston ring gap in bore.

Maximum service allowance:
Replace when it goes beyond 0.45mm (.018 in.).

5. Measure the ID of the piston pin hole.

Maximum service allowance:
Replace when it goes beyond 13.04mm (.51 in.).

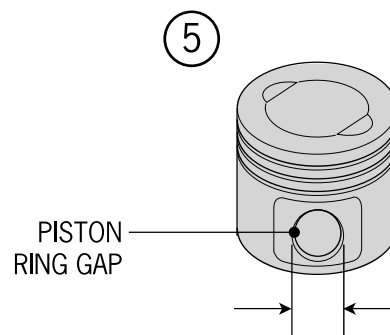
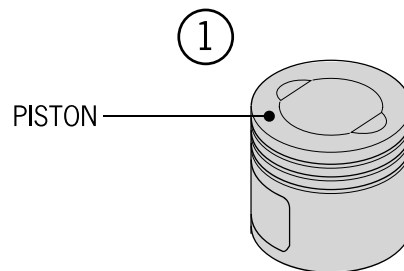
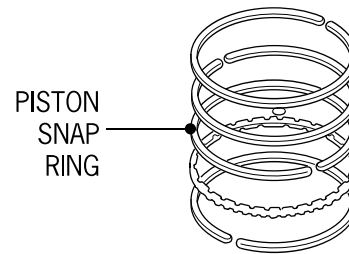
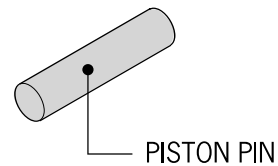

6. Cylinder and Piston

6. Measure the OD of the piston pin.

Maximum service allowance:

Replace when it is below 12.96 mm, (.51 in.).

7. Measure the OD of the piston.



Attention:

Measure it in a position which forms 90 degree with the center of the piston pin and which is 9mm away from the skirt.

Maximum service allowance:

Replace when it is below 38.7 mm (1.52 in.).

8. Measure the clearance between the piston pin and the pin hole.

Maximum service allowance:

Replace when it goes beyond 0.02 mm (.0008 in.).

Checking the Cylinder

1. Check whether it's scratched, worn or damaged in its inner surface.

2. Measure its ID in three positions (upper, middle and lower) which form 90 degrees (x-y direction) with the piston hole.

Maximum service allowance:

Repair or replace when it goes beyond 0.1mm (.004 in.).

The difference between X and Y directions is out-of-roundness.

The cylindricity is the ID difference (between X and Y directions), measuring at three positions (upper, middle and lower). The largest measured value will be considered the result. This indicates a taper of the cylinder.

Maximum service allowance:

Out-of-roundness:

Repair or replace when it goes beyond 0.05mm (.002 in.).

Cylindricity:

Repair or replace when it goes beyond 0.05mm (.002 in.).

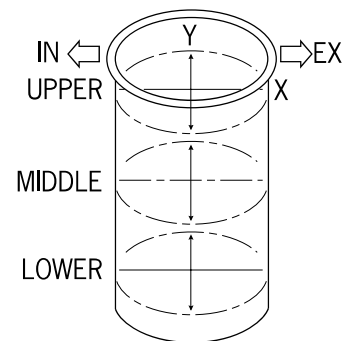
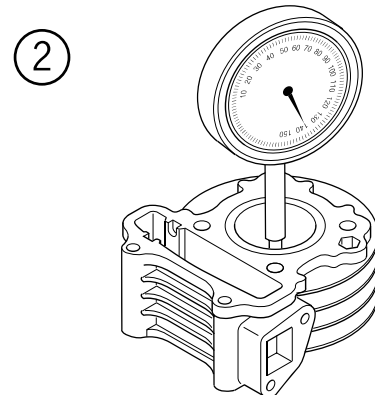
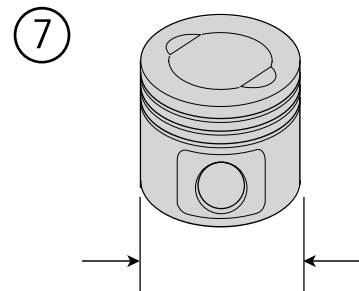
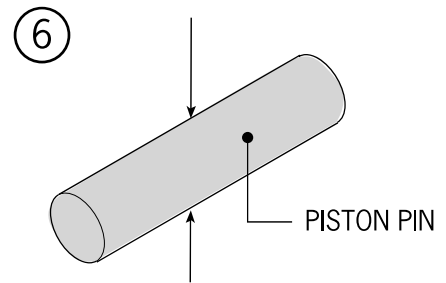

6. Cylinder and Piston

3. Check the distortion of the cylinder.

Maximum service allowance:
Repair or replace when it goes beyond 0.05mm (.002 in.).

2

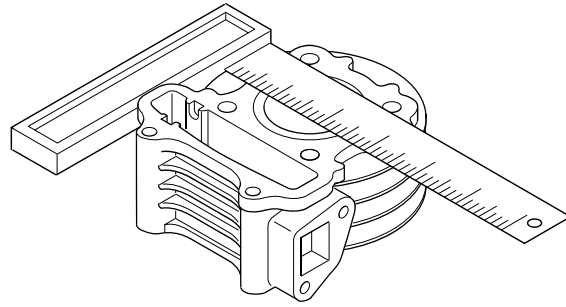

4. Measure the ID of the small end of the connecting rod.

Maximum service allowance:
Replace when it goes beyond 13.06mm (.51 in.).

4

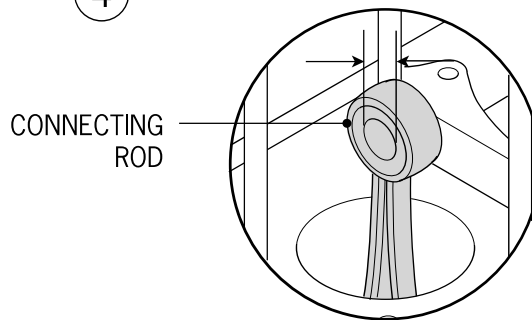

Attention:
Don't scratch the piston or break the piston ring.

When replacing the ring, keep the surface with the "T" mark up.

After assembling, make sure that the ring can be turned freely in the ring groove.

6

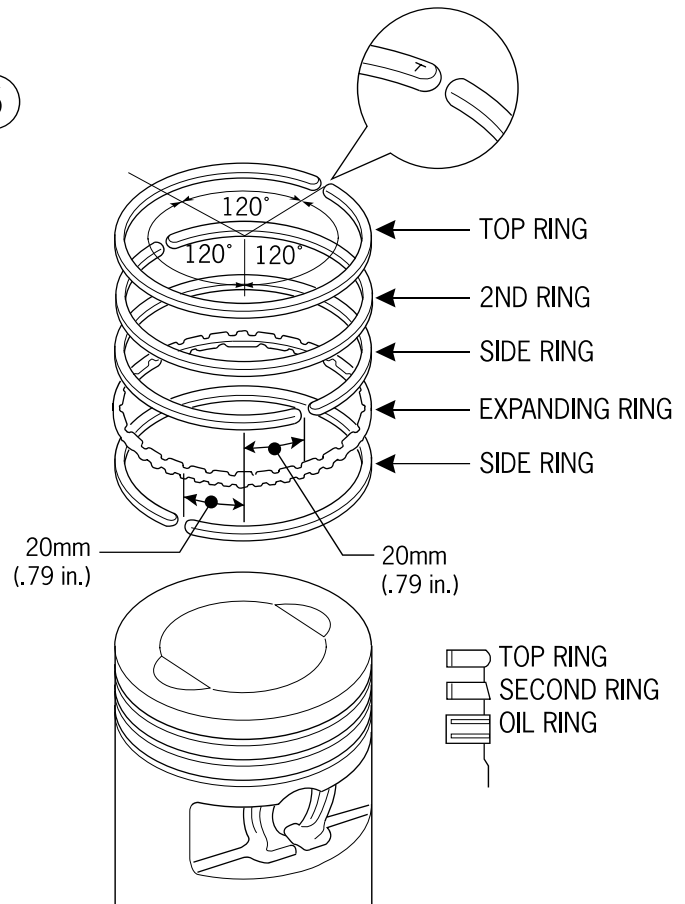

5. Lightly coat the rings with engine oil before installing them on the piston.

6. Make sure to keep ring end gaps rotated at 120° increments.

7. Cover piston and rings with a light coat of engine oil.

6. Cylinder and Piston

8. Install the chain guide lever of the cam.

Attention:
Make sure that the lug of the guide lever enters the notch of the cylinder.

Assembling the Piston

1. Scrape away the gasket adhering on the surface of the crankcase.

Attention:
Be sure not to let any matter drop into the crankcase.

2. Assemble the piston and the piston pin.

Attention:
When assembling, keep the mark "in" (on the top of the piston) toward the inlet valve.

Attention:
Be sure not to let the piston pin snap ring fall into the crankcase. Use a cloth to keep debris out of the crankcase.

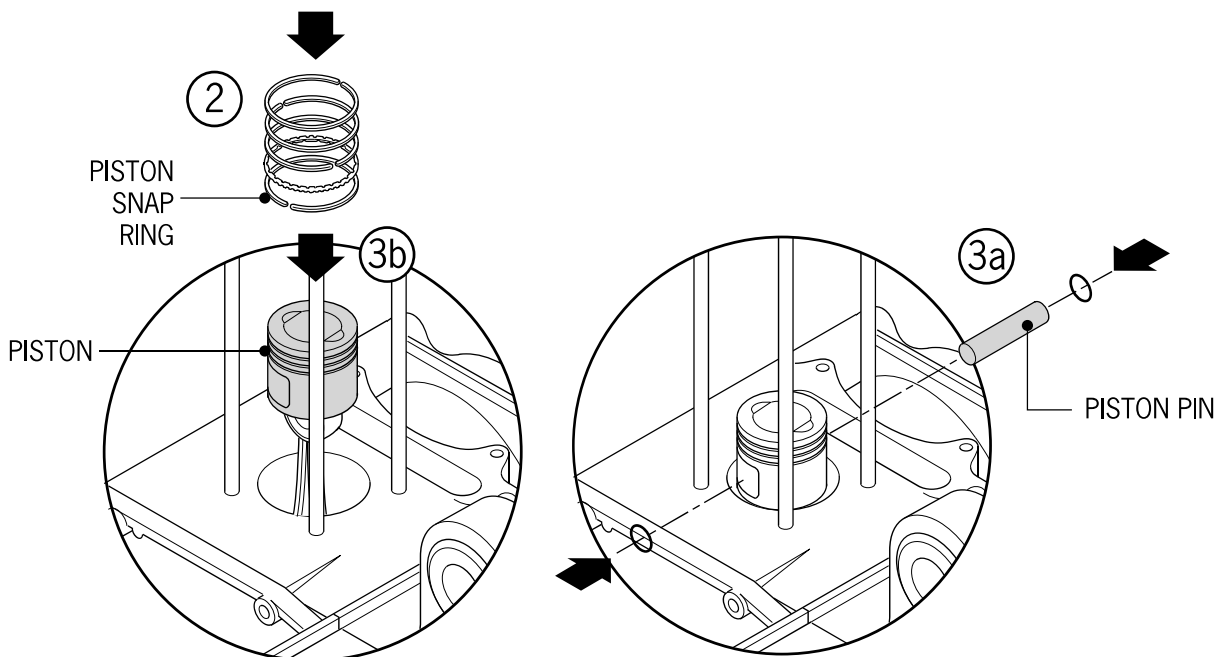
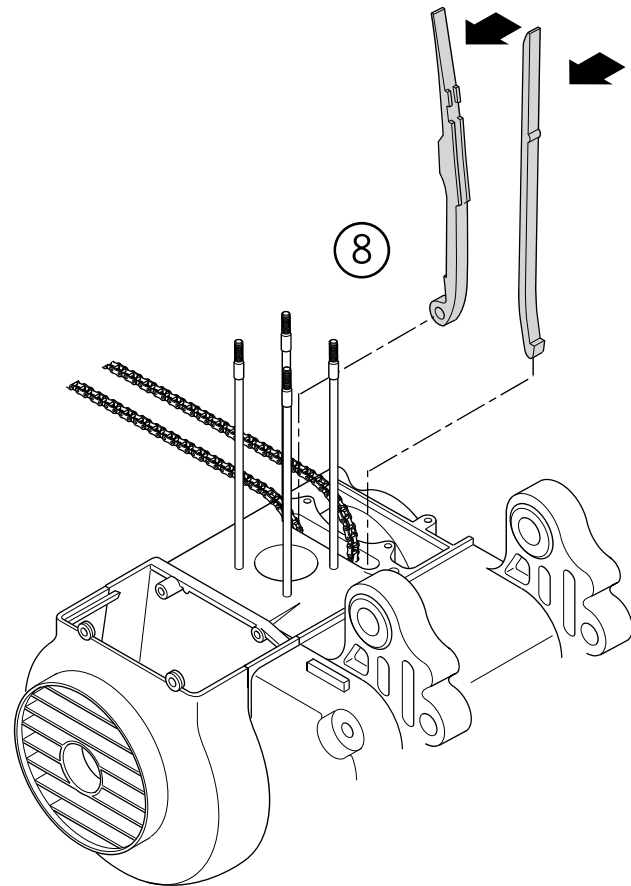

6. Cylinder and Piston

Assembling the Cylinder

3. Install the locating pin and the gasket to the crankcase.
4. Coat the inner surface of the cylinder, the piston and the piston ring with oil.
5. When assembling the piston rings, they must be compressed into the cylinder.



Attention:

Don't damage or break the piston ring.



Be sure not to make the position of the ring gap point to the inlet and outlet valves and parallel with the piston ring.

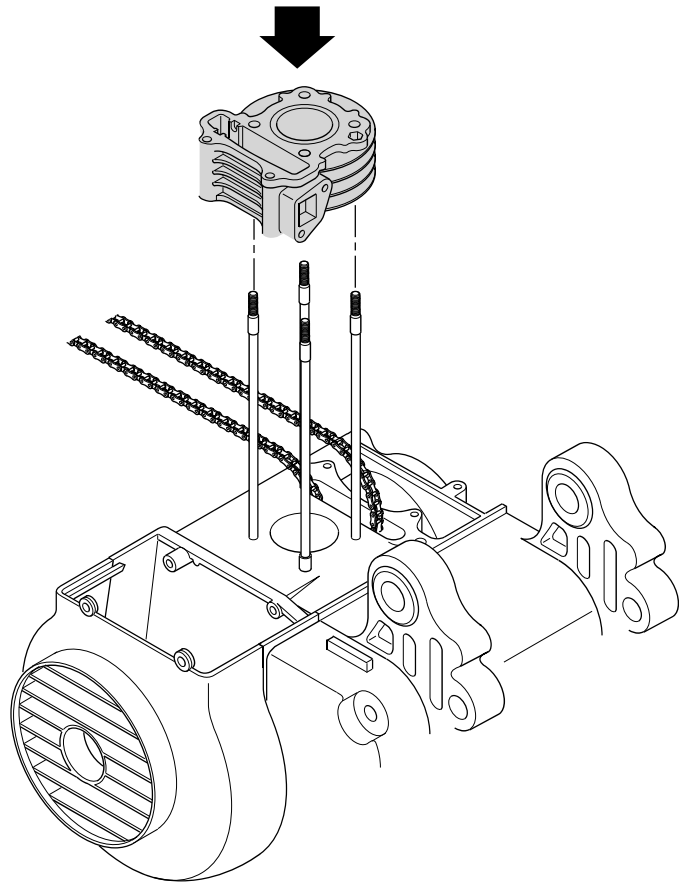

7. Driving Belt Device & The Starting Lever

Topic	Page	Topic	Page
Important Points	9-2	The Clutch/Transmission Pulley	9-10
Troubleshooting	9-2	Removing the Clutch/ Transmission Pulley	
Detaching the Left Crankcase Cover	9-3	Disassembling the Clutch/ Transmission Pulley	9-10
Removing the Starting Pivot	9-3	Checking the Clutch	9-11
Checking the Starting Pivot	9-4	Transmission Pulley	
Installing the Starting Assembly	9-4	Replacing the transmission pulley and the bearing	9-12
Assembling the Left Crankcase Cover	9-5	The Clutch/Transmission Pulley Assembly	9-13
Checking the Driving Belt	9-6	Assembling the Clutch Housing	9-14
Replacing the Driving Belt	9-6		
Assembling the Driving Belt	9-7		
The Driving Pulley-Dismounting	9-7		
Taking the Driving Pulley Apart	9-7		
Checking the Driving Pulley	9-8		
Assembling the Driving Pulley	9-9		
The Overrunning Clutch Removal	9-9		
Checking and Assembling the Overrunning Clutch	9-9		

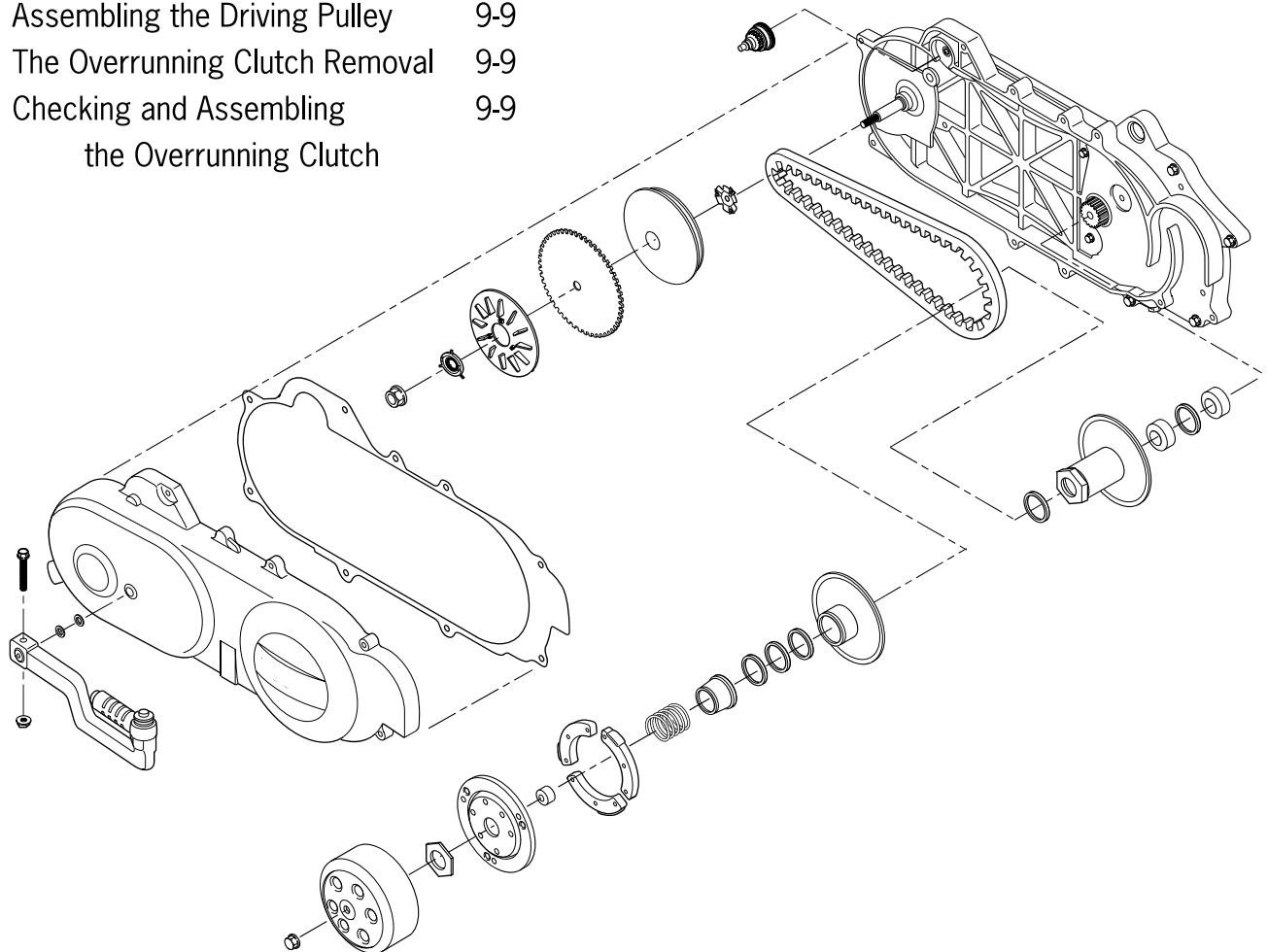

7. Driving Belt Device & The Starting Lever

Important Points

- This chapter is about the driving unit, the clutch/driven unit and the starting lever.
- The surface of the driving belt and the drive units are not allowed to have oil adhering to them. If there is any, remove it to minimize the slip between the belt and the drive units.
- The work on them can be done on the engine, without the disassembly.

Tech Criterion

Item	Normal Size	Max. Service Allowable
ID of the sleeve of the sliding driving plate	23.989-24.05-	24.24
OD of the hub of the sliding driving plate	20.010-22.025	19.97
Width of the driving belt	18	17
Thickness of the clutch brake lining		2.0
ID of the clutch housing	107.0-107.22	107.5
Free length of the driven belt spring	98.1	107.5
OD of the driving plate	33.965-33.985	92.8
ID of the sliding driving plate	34.0-34.25	34.06
OD of the roller	13.0	12.4

Torque

- The nut of the driving plate
3.8kg/m 28ft lbs
- The nut of the clutch housing
5.5kg/m 40ft lbs
- The bolt of the driving plate
0.3kg/m 40in lbs
- The nut of the clutch/driving plate
0.45kg/m 40in lbs



- Universal stand



- Compressing device for clutch spring
- Socket (39mm) for Socket (39mm) for the fix nut
- Bearing driver

Troubleshooting

The motorcycle doesn't run after the engine is started

- The driving belt is worn
- The driving plate is broken
- The brake lining is worn or broken
- The spring of the driven plate is fractured

Sudden breakdown during running

- The spring of the brake lining is fractured

Power can't develop fully

- The driving belt is worn
- Distortion of the driven belt spring
- The roller is worn
- The driving plate surface is dirty

7. Driving Belt Device & The Starting Lever

Detaching the Left Crankcase Cover

1. Unlock the clip for the air tube for the driving belt.
2. Remove eight bolts and then take off the left crankcase cover and the locating pin.
3. Check whether the gasket is damaged or fractured.

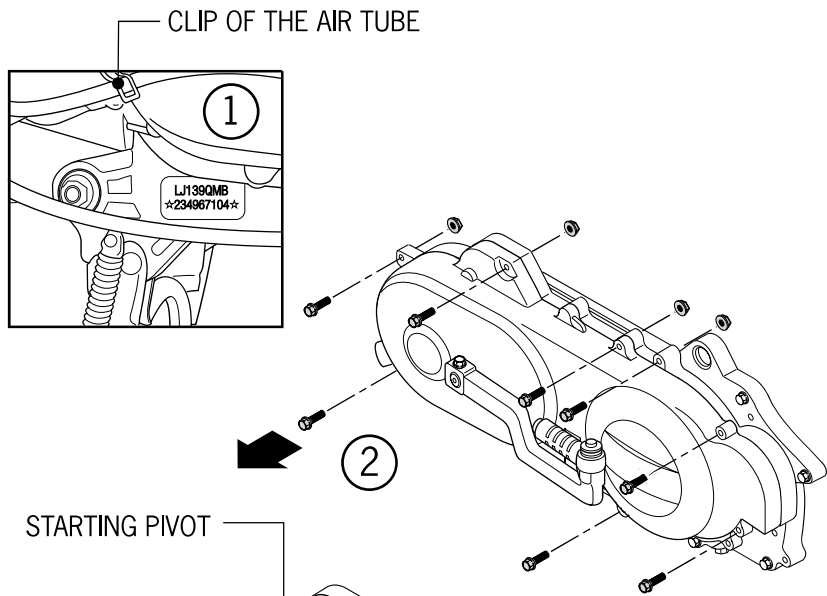

Removing the Starting Pivot

1. Remove the starting lever from the pivot.
2. Remove the retainer and the washer from the starting pivot.
3. Turn the starting pivot gently and remove the driving gear and the friction spring together.
4. Remove the starting pivot and the return spring.
5. Detach the starting pivot sleeve.

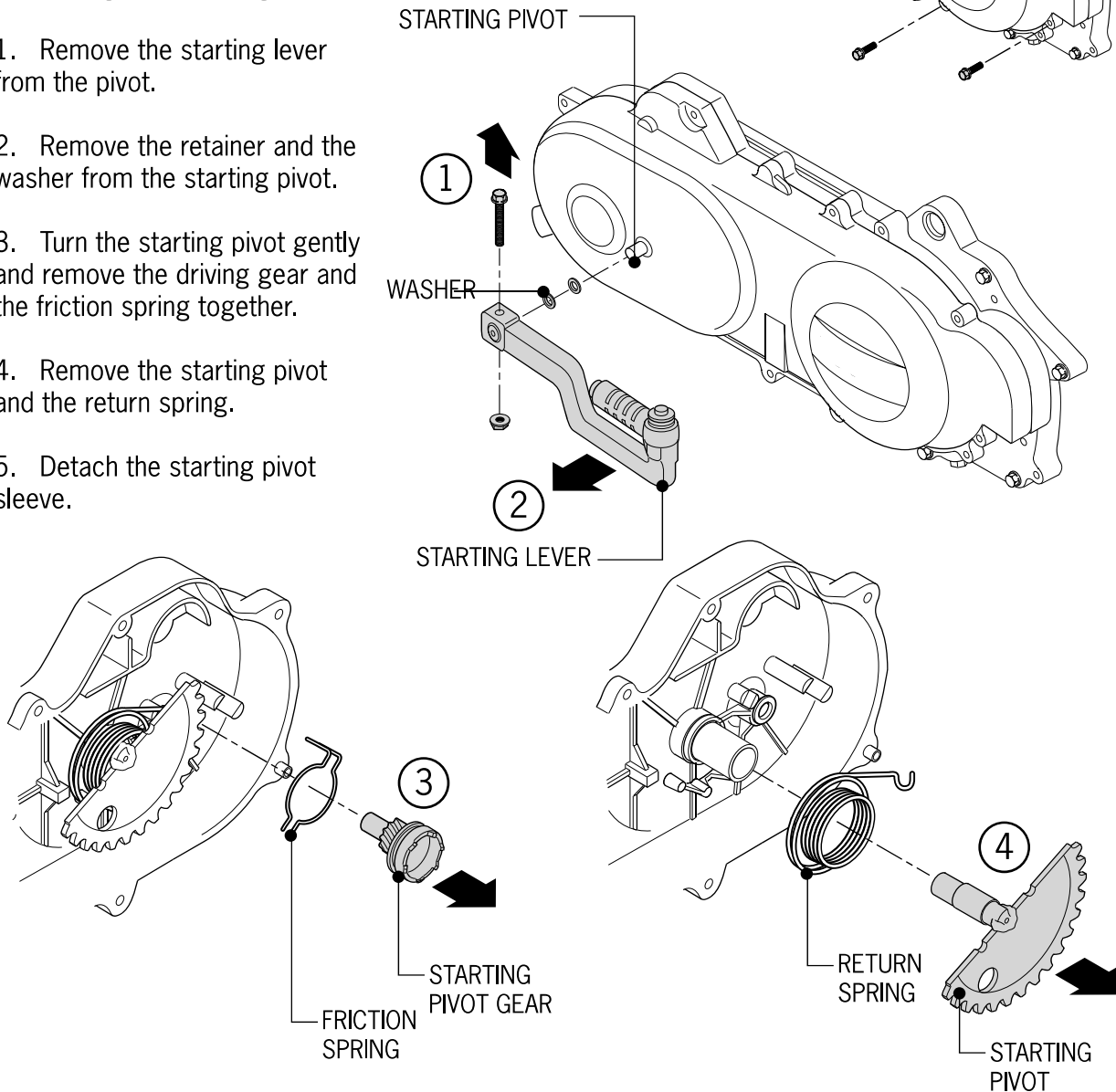

7. Driving Belt Device & The Starting Lever

Checking the Starting Pivot

1. Check if the pivot and the gear are worn. Check if there is any softness of the starting return spring. Check if there is any excessive wear on the pivot sleeve.

2. Check if the driven gear is worn or has failed. Check if the friction spring is worn or fractured.

3. Check if there is any excessive wear on the bearing part of the starting pivot and of the shaft of the driven gear. Replace any parts showing excessive or unusual wear.

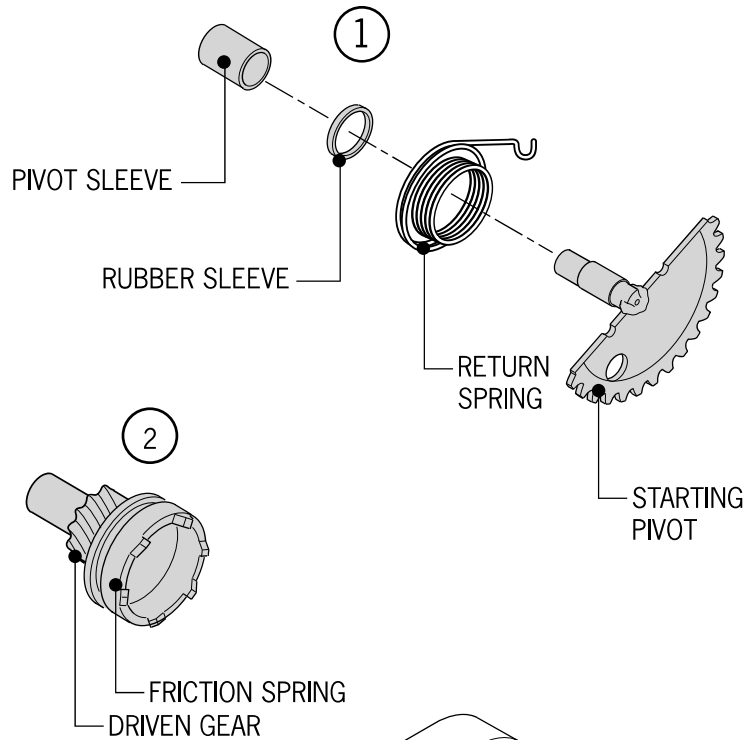

Installing the Starting Assembly

1. Install the starting pivot sleeve and the return spring to the crankcase cover.

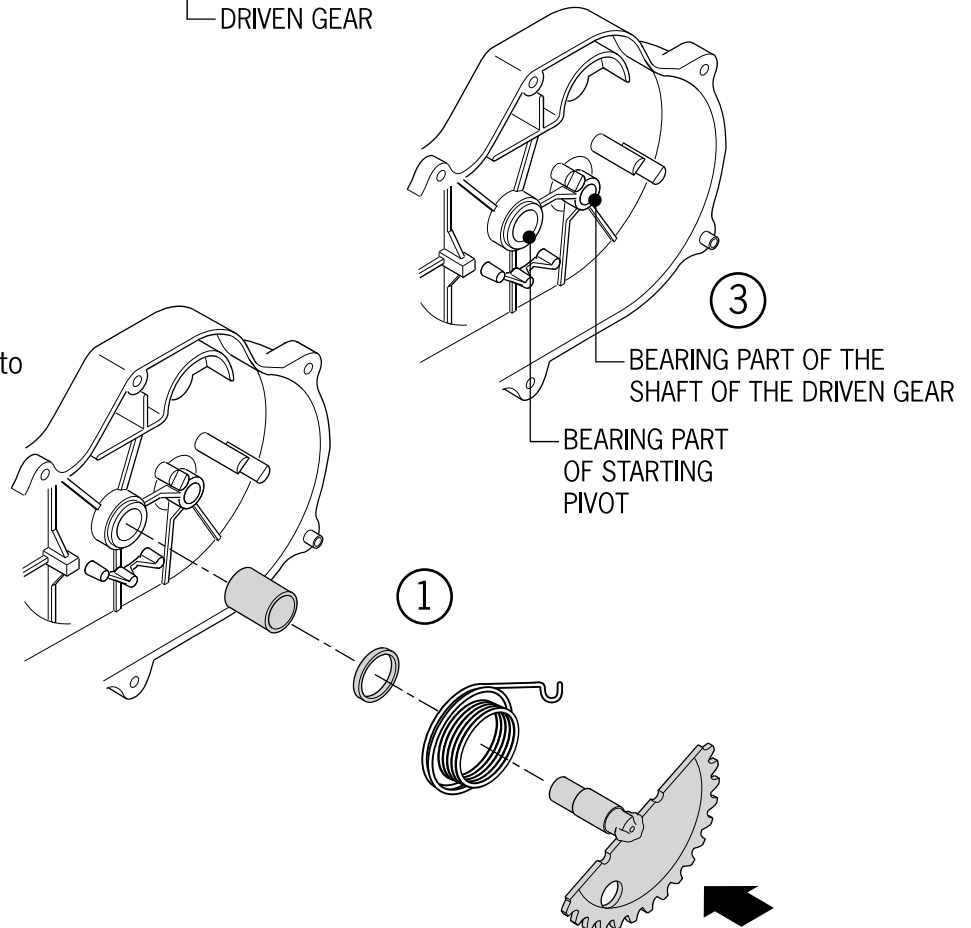

7. Driving Belt Device & The Starting Lever

2. As shown in the picture on the right, assemble the driven gear and the friction spring. Maintain the orientation as shown.

3. Install the starter pivot (3a). Install the washer, then the retainer (3b).

Assembling the Left Crankcase Cover

1. First, install the locating pin, then the gasket.

2. Assemble the left crankcase cover, and then tighten the eight fix bolts diagonally. Install the air tube together, and then install the retainer.

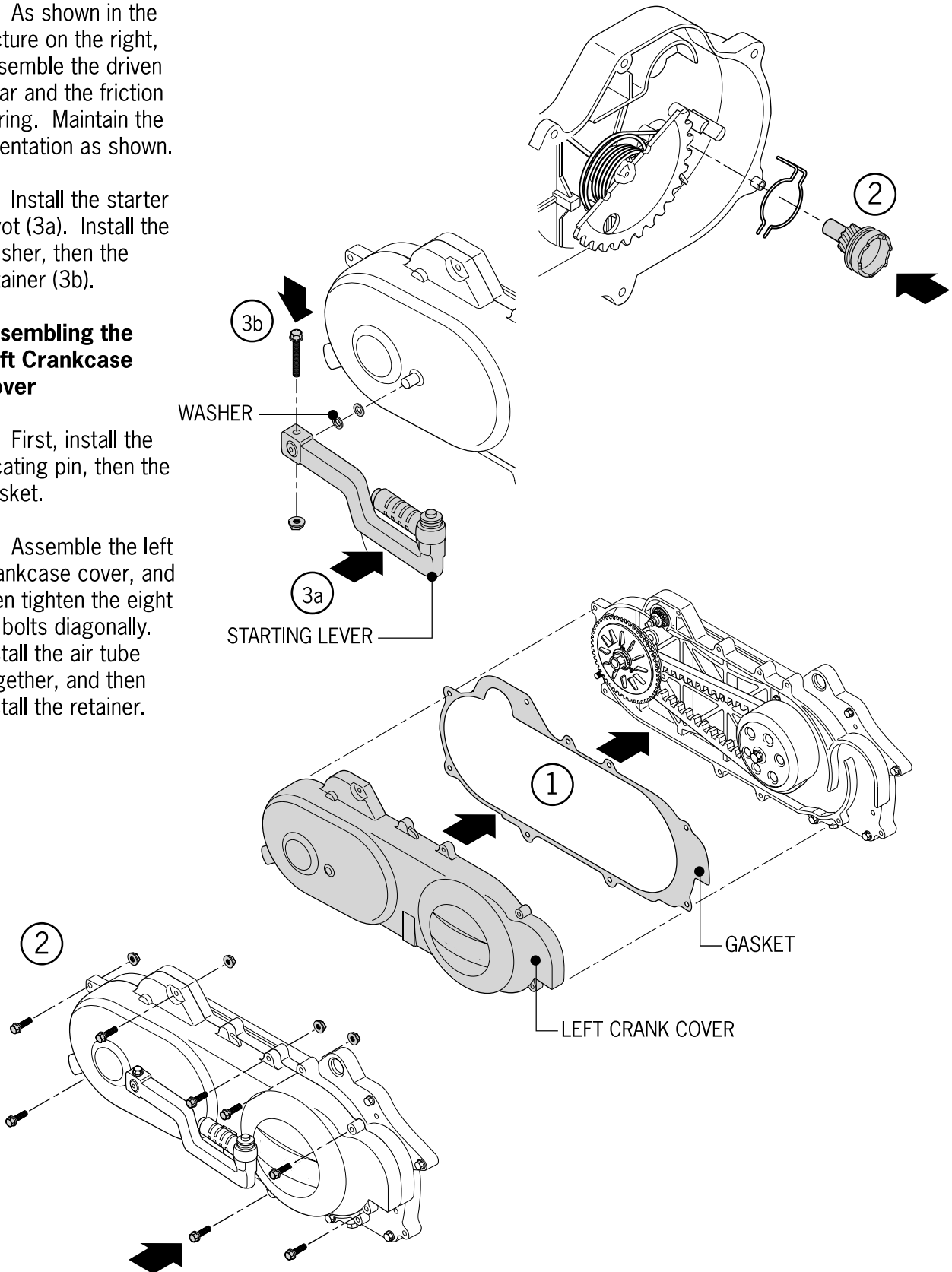

7. Driving Belt Device & The Starting Lever

Checking the Driving Belt

- 1. Detach the left crankcase cover.
- 2. Check if the driving belt is cracked, frayed, or if there is abnormal wear. Measure the width of the belt. Maximum service allowance: 17mm (.7 in.).

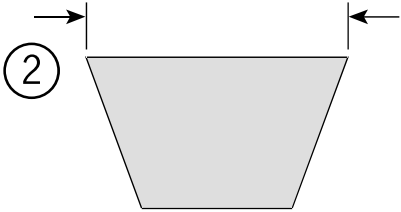

Replacing the Driving Belt

- 1. Remove the eight fix bolts, then remove the crankcase cover.
- 2. Remove driving pulley. Use a retaining device to hold the driving pulley and screw out of the 10mm (.39 in.) bolt.
- 3. Remove the driving pulley.
- 4. Remove the driving belt from the clutch driving pulley.

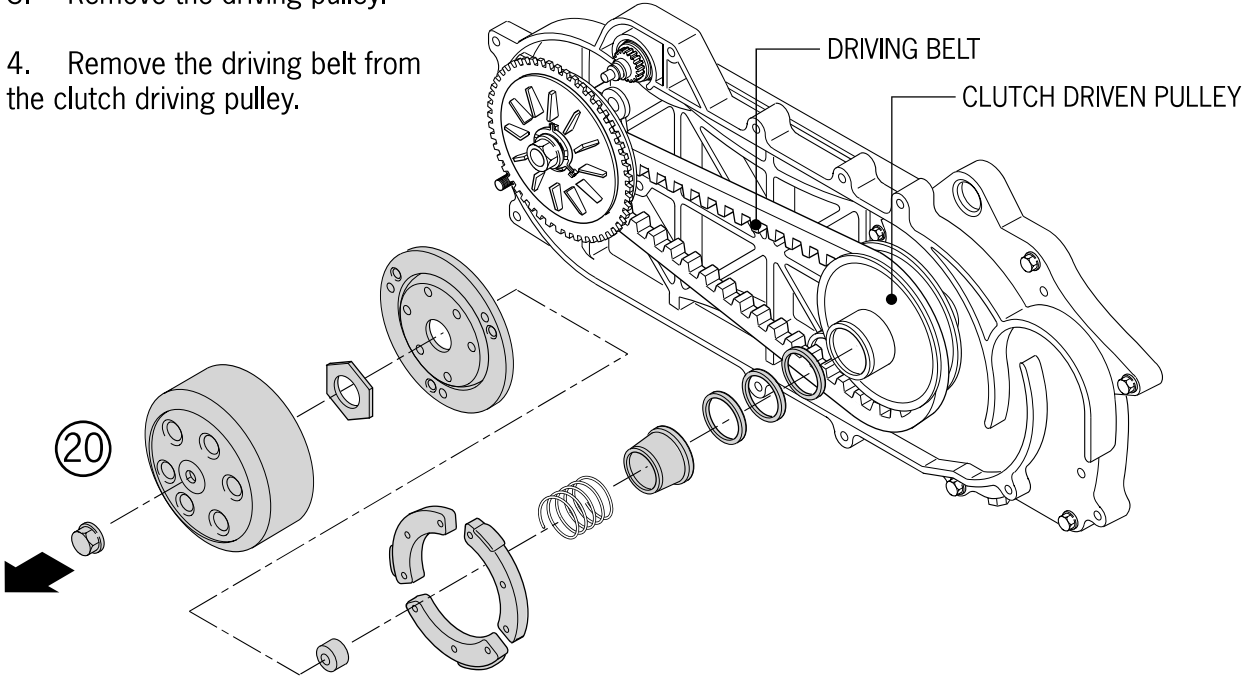
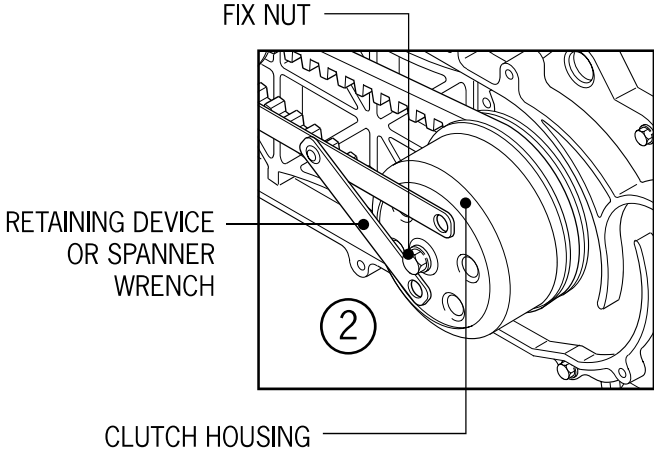

7. Driving Belt Device & The Starting Lever

Assembling the Driving Belt

1. Turn the driving pulley clockwise to keep the notches of the belt in expanded condition. Then install the new driving belt.
2. Install the driving belt on the driving pulley. Install the driving pulley, the starting ratchet and 10mm (.39 in.) washer. Then install and tighten the nut. Torque: 3,8kg/m 28ft lbs



Attention:

During assembly, be sure to align the splints of the driving unit with those on the crank shaft with the ratchet.

The Driving Pulley-Dismounting

3. Use a retaining device or spanner wrench to hold the driving pulley.
4. Screw out the 10mm (.39 in.) nut, and then remove the ratchet, the 10mm (.39 in.) nut and the driving pulley.

Taking the Driving Pulley Apart

5. Remove the driving pulley and the sleeve from the crankshaft.

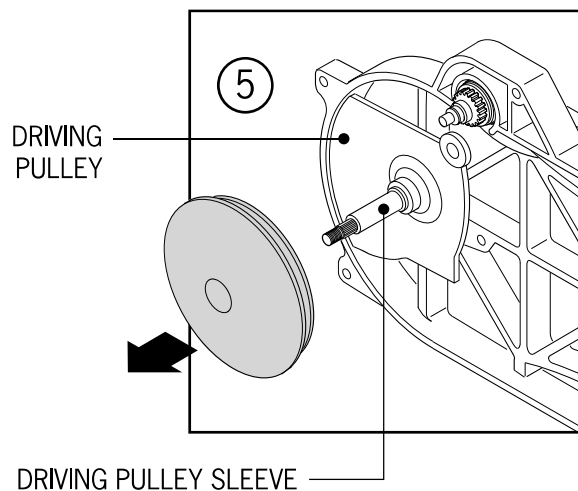
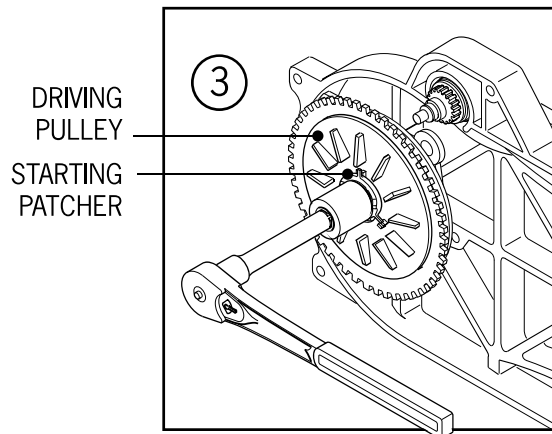
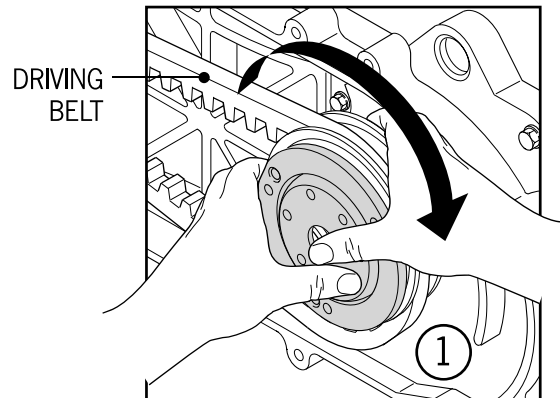

7. Driving Belt Device & The Starting Lever

6. Remove the retainer.
7. Remove the rollers.

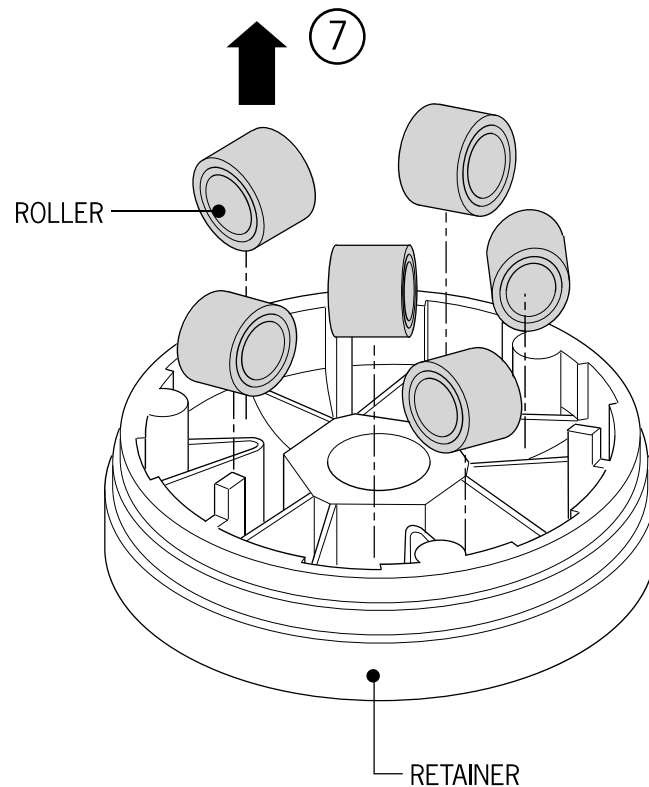

Checking the driving pulley

1. Check the wear of the rollers. Measure the OD of the roller.

*Maximum service allowance.
Replace when it is below 12.4mm
(.47 in.).*

2. Check the wear of the driving pulley sleeve. Measure the OD of the moving section of the sleeve.

*Maximum service allowance:
Replace when it is below 33.94mm
(1.37 in.).*

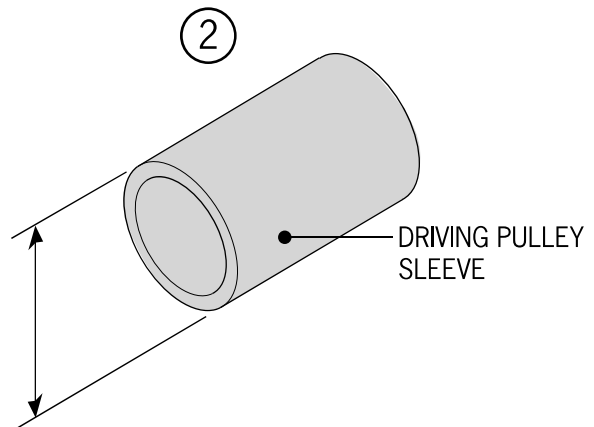

7. Driving Belt Device & The Starting Lever

Driving Pulley

Install the driving pulley sleeve and the driving pulley on the crankshaft (1a). Install the driving belt on the crankshaft (1b). Install the driving pulley and the washer (1c).

Tighten 10mm (.39 in.) nut.
Torque: 3.8kg/m 28ft lbs

Attention:
There mustn't be any grease on the surface of the driven belt and the driving pulley.

The Overrunning Clutch (Starter Pinion) Removal

2. Remove the left crankcase cover .
3. Remove the driving pulley.
4. Remove the seat of the overrunning clutch.
5. Remove the overrunning clutch.

Checking and Assembling

6. Check if the bearing part of the overrunning clutch shaft is worn.
7. Check if the clutch runs smoothly.
8. Check the wear of the gear and the bearing part of the shaft.
9. Coat the bearing part of the clutch shaft with a bit of grease.
10. Assemble it in the opposite sequence of removal.

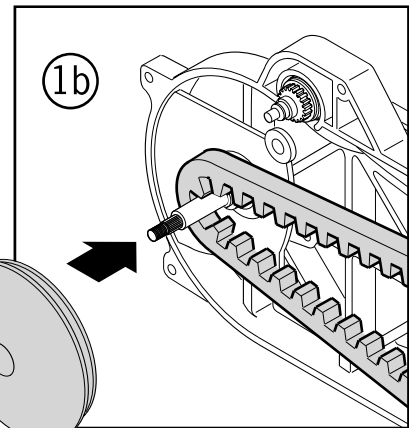
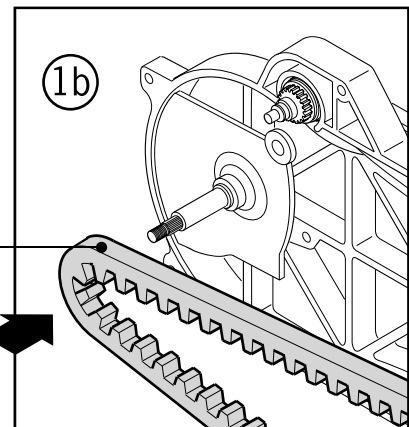
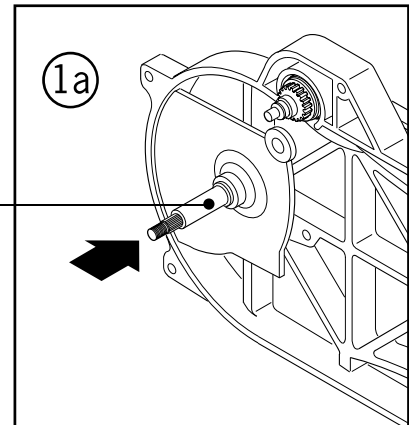

Overrunning Clutch

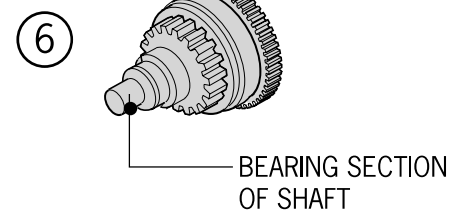
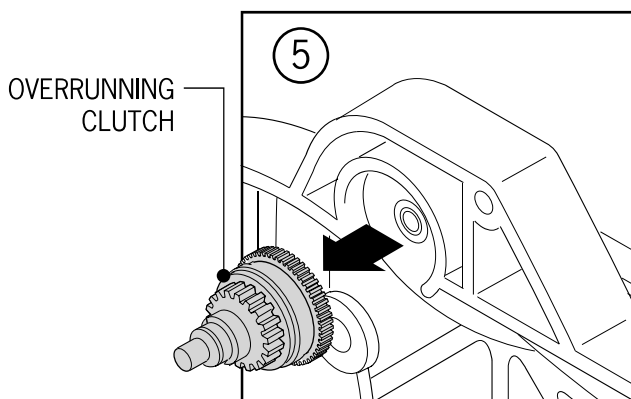

7. Driving Belt Device & The Starting Lever

The Clutch/Transmission Pulley Removing the Clutch/Transmission Pulley

1. Remove the driving pulley. Then use a spanner wrench to hold the clutch housing to screw out the 10mm (.39 in.) nut.

2. Remove the clutch housing. Remove the clutch/transmission pulley. Remove the driving belt from the clutch/transmission pulley.

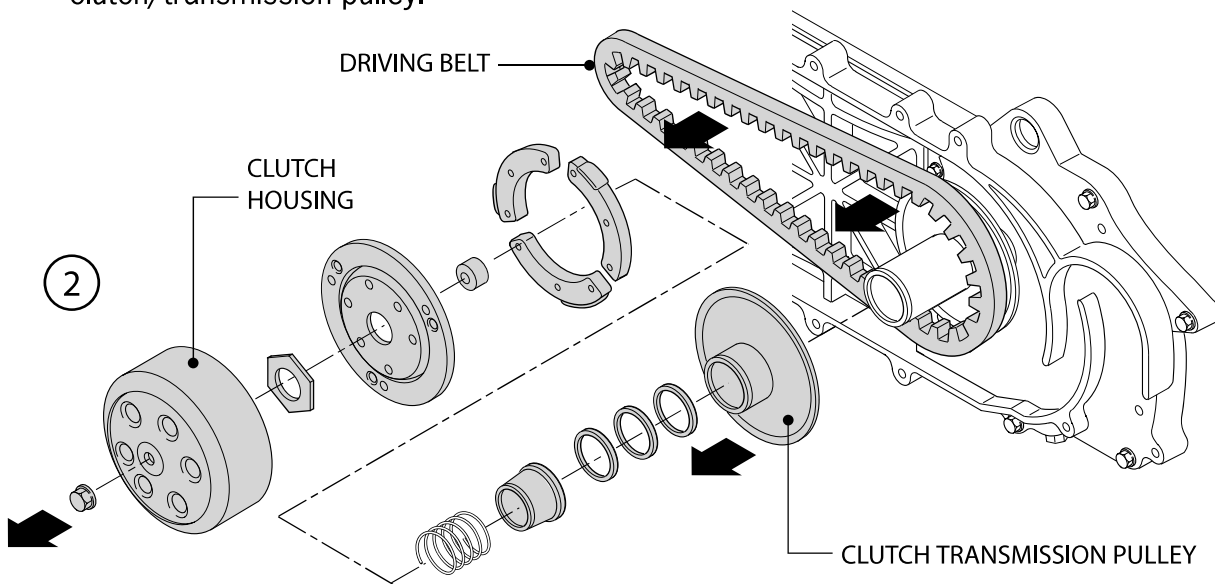
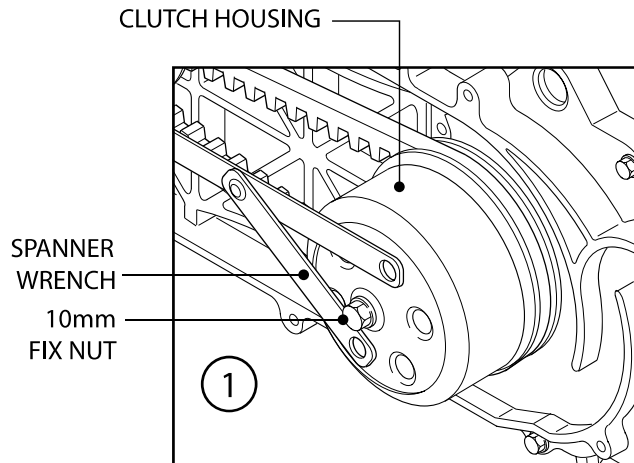

Disassembling the Clutch/Transmission Pulley

5. Use a spring compressor for the clutch spring to press down the transmission pulley spring to remove the special nut (28mm, 1.102 in.).

6. Remove the clutch spring.

7. Remove the sealing cover of the shaft collar.

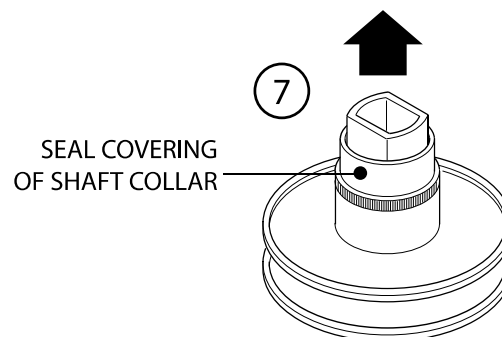

7. Driving Belt Device & The Starting Lever

8. Remove the guide rolling pin from the transmission pulley assembly, and then take out the o-ring and the oil seal.

Checking the Clutch Transmission Pulley

1. Check the wear of the clutch housing. Measure the ID of the clutch housing.

*Maximum service allowance:
Replace when it goes beyond
107.5mm (4.23 in.).*

2. Check the wear of the clutch lining. Measure the thickness of the lining.

*Maximum service allowance:
Replace, when it is below 2.0mm
(.078 in.).*

3. Measure the free length of the transmission pulley spring.

*Maximum service allowance:
Replace when it below 92.8mm
(3.65).*

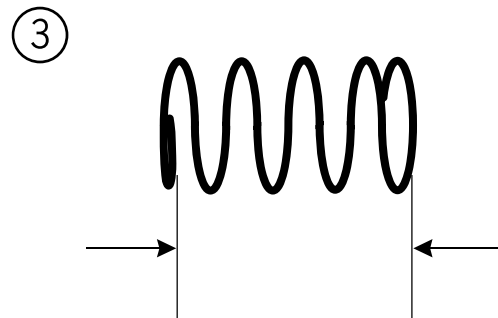
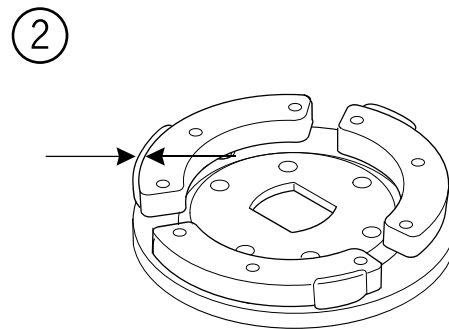
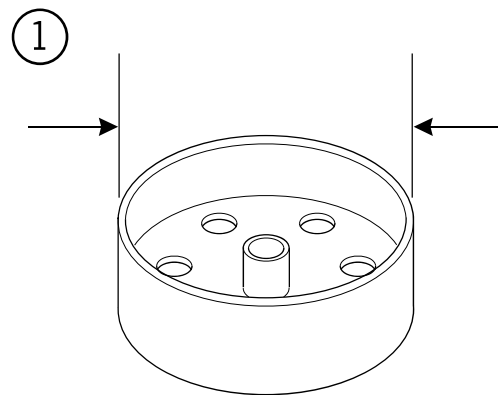
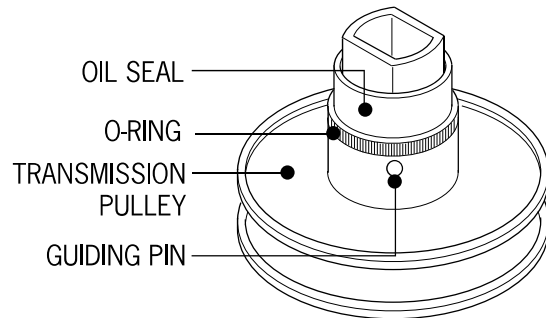

7. Driving Belt Device & The Starting Lever

4. Check the wear of the transmission pulley. Measure the OD of the pulley.

*Maximum service allowance:
Replace when it is below 19.97mm
(.79 in.).*

5. Check the wear of the transmission pulley. Measure the ID of the pulley.

*Maximum service allowance:
Replace when it goes beyond 24.24mm
(.95 in.).*

6. Check if the guide rolling pin is excessively worn or unevenly worn. Replace as necessary.

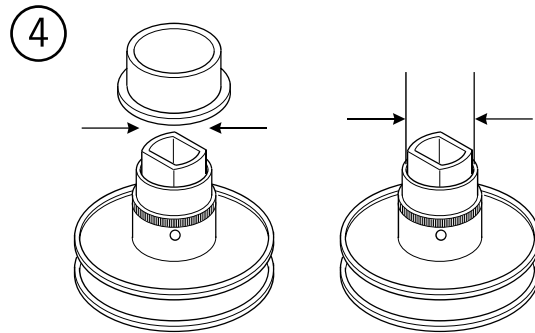

Replacing the transmission pulley and the bearing

1. Check the needle bearing for wear or excessive free play, gritty feel or noise. Replace as necessary.
2. Check the housing bearing for wear. Remove the retainer and take out the housing bearing.
3. Drive in the new housing bearing, keeping the lid side up.



Attention:

Grease new bearings when installing. Grease able to resist > 230°.

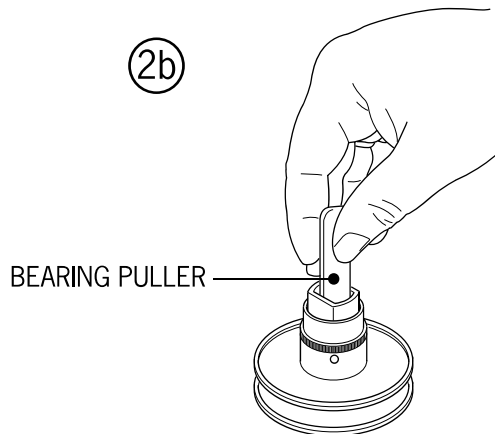
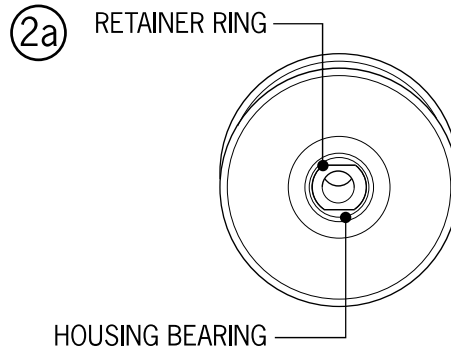
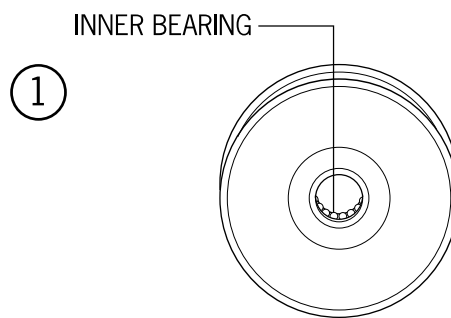

7. Driving Belt Device & The Starting Lever

4. Drive in the new needle bearing, keeping the "mark" side up.

The Clutch/Transmission Pulley Assembly

1. Assemble the transmission pulley guide pin and oil seal.
2. Install the sealing cover of the collar.
3. Assemble the transmission pulley disk and the spring to the clutch assembly, pressing down with the spring compressor for the clutch spring.
4. Install the 28mm fix nut and tighten it.

Torque: 5.0-6.0kg/m 35-40ft lbs

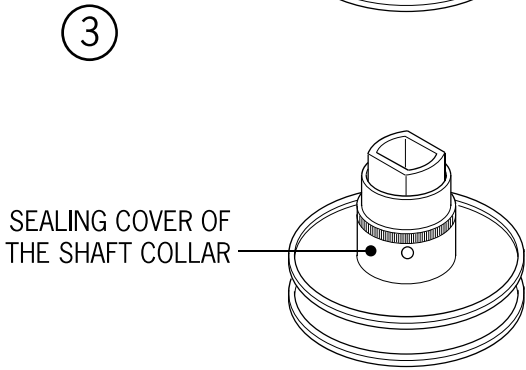
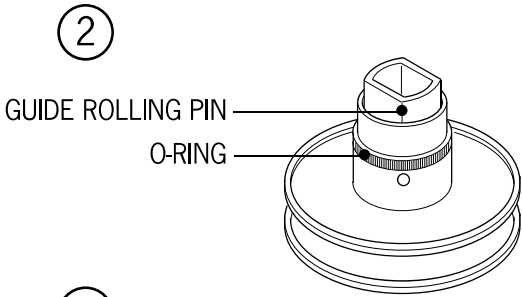
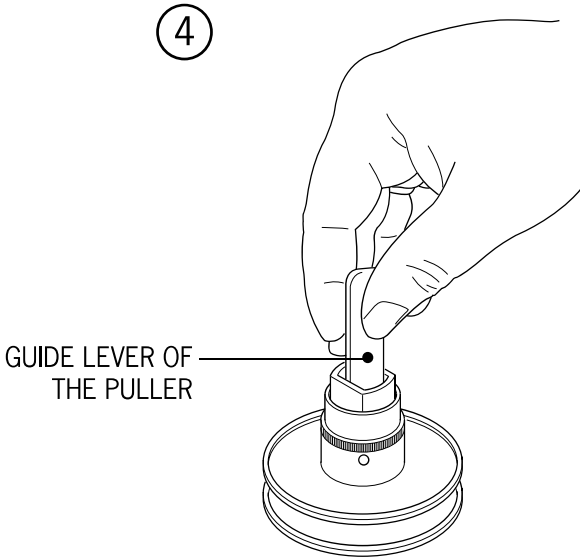

7. Driving Belt Device & The Starting Lever

4. Assembling the clutch/transmission pulley, put the driving belt onto the clutch/transmission pulley, then onto the driving shaft.

Assembling the Clutch Housing

5. Use a spanner wrench to hold the housing, then install the 10mm (.39 in.) nut and tighten it.

Torque: 5.5kg/m 38ft lbs
Assemble the left crankcase cover.

CLUTCH HOUSING

SPANNER
WRENCH
10mm
FIX NUT

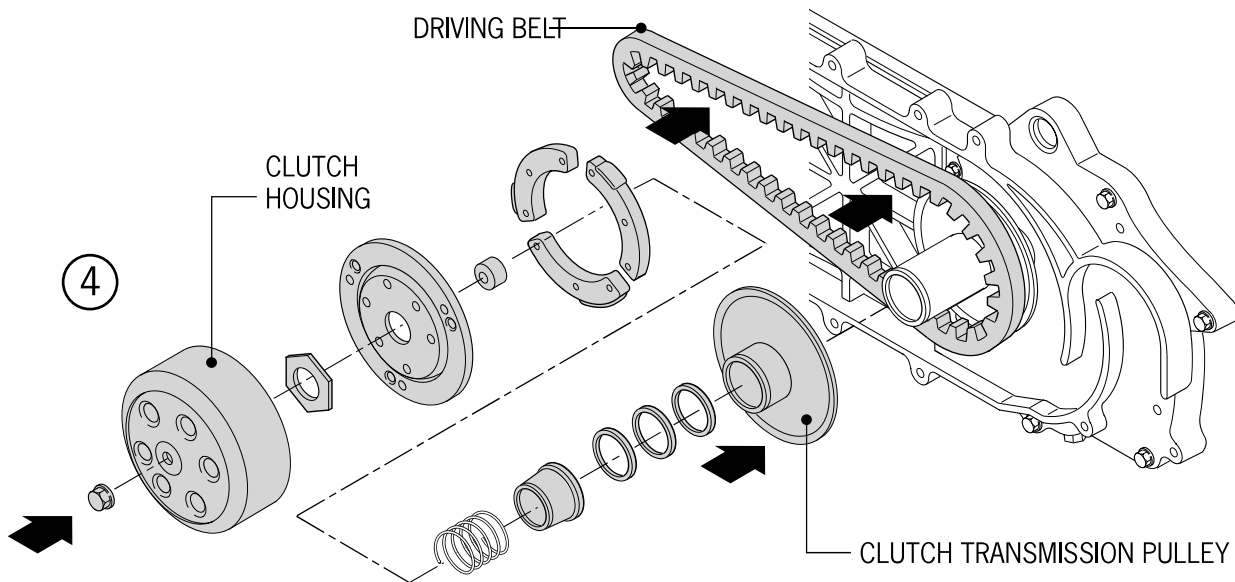
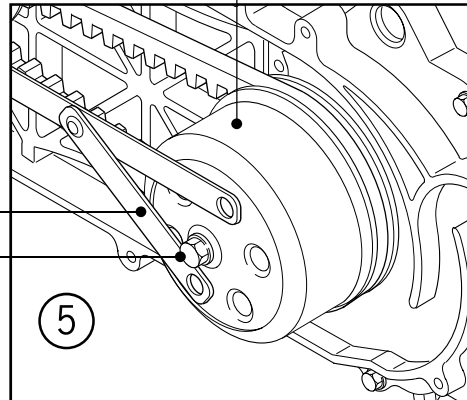

8. The Final Transmission Assembly

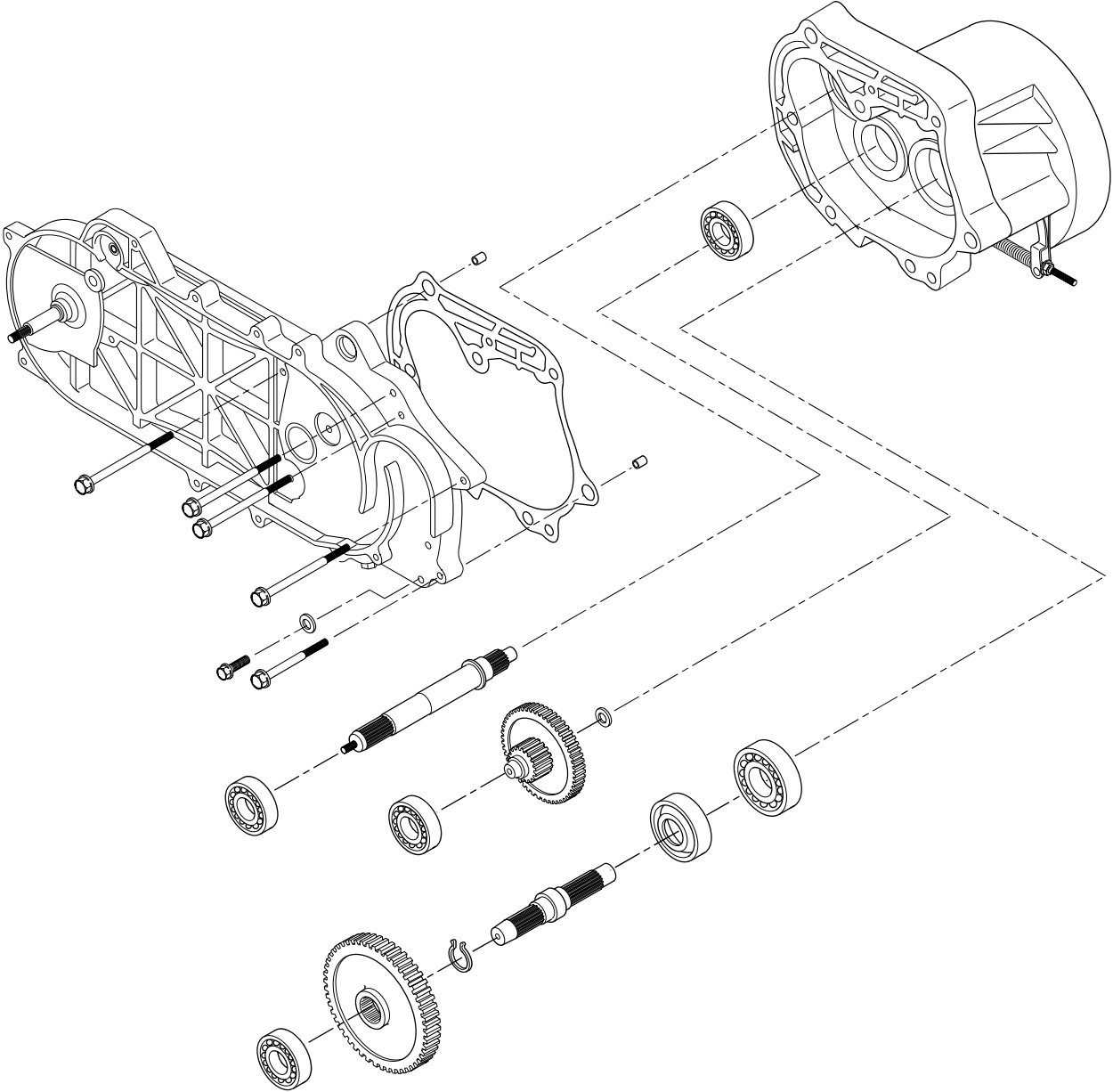

8. The Final Transmission Assembly

Topic	Page	Topic	Page
General Information	10-2	Replacing the Bearing	10-5
Dismantling the Final Transmission Assembly	10-3	(on the side of the crankcase)	
Replacing Bearing	10-4	Assembling the Final Gear Set	10-5
(on the side of the transmission gearbox cover)			

General Information

- Designated oil: SAE 90# Gear Oil
- Filling 0.12L 4 ounces
- Changing 0.10L 3.5 ounces



- Bearing pulling set 12mm
- Bearing pulling set 15mm
- Sleeve shaft for assembling the crankshaft
- Sleeve lever for assembling the crankshaft



- Bearing outer race driver 3740mm
- Bearing outer race driver 3235mm
- Guide lever for the bearing driver 17mm
- Guide lever for the bearing driver 15mm
- Guide lever for the bearing driver 12mm
- Bearing driver

Troubleshooting

The scooter doesn't run after the engine is started

- The transmission gear failed
- The driving belt is worn or broken
- The clutch failed

Developing abnormal noise when it runs

- The gear is worn, burnt or has damaged teeth
- The bearing is worn and getting loose

Oil leakage

- Too much oil
- The oil seal is broken

8. The Final Transmission Assembly

Dismantling the final transmission assembly

1. Remove the rear brake cable.
2. Remove the rear wheel (refer to 13-3).
3. Remove the left crankcase cover (refer to 9-2).
4. Remove the driven pulley of the clutch (refer to 9-5).
5. Drain the oil out of the final transmission.
6. Remove the bolts of the final transmission gearbox.
7. Remove the transmission gearbox cover.
8. Remove the gasket and the locating pin.

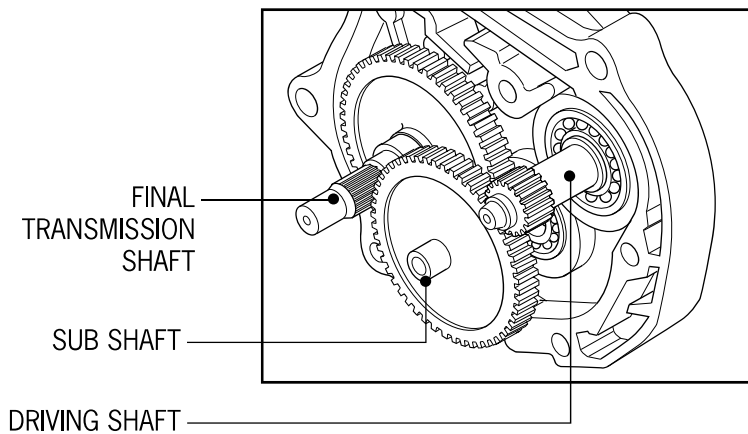
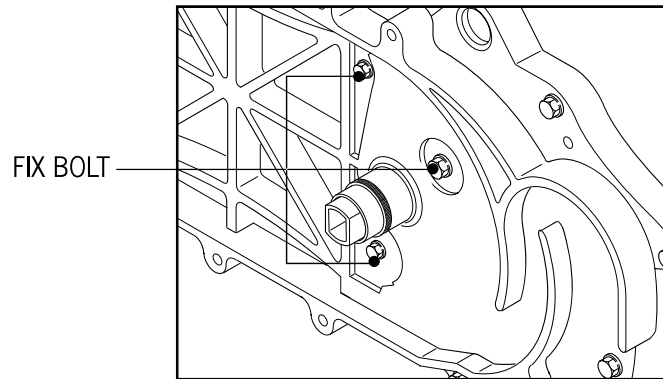

Detach the final transmission gearbox cover

1. Check the final transmission assembly.
2. Check if the sub shaft gear is worn or damaged.
3. Check if the final transmission gear is burnt or damaged.

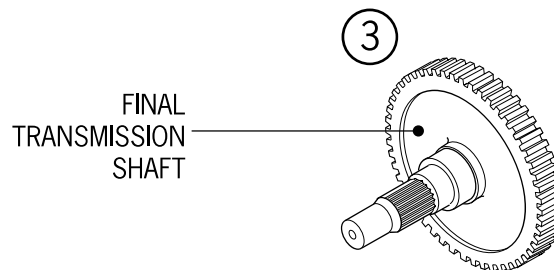
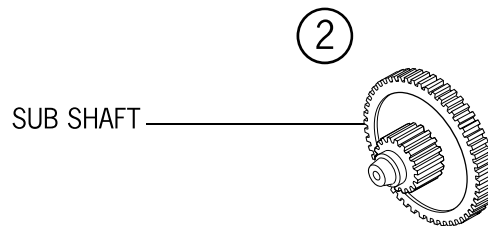

8. The Final Transmission Assembly

4. Check if the bearing in the left crankcase and the oil seal are worn or damaged.

5. Check if the driving shaft (the main clutch shaft) and the gear are worn or damaged.

6. Check if the oil seal in the bearing of the transmission gearbox cover and that of the bearing of the final gear shaft are worn or have failed.



Attention:

Don't dismantle the final transmission gearbox, except that some parts have to be replaced. While replacing the driving shaft, the oil seal must be replaced by new ones.

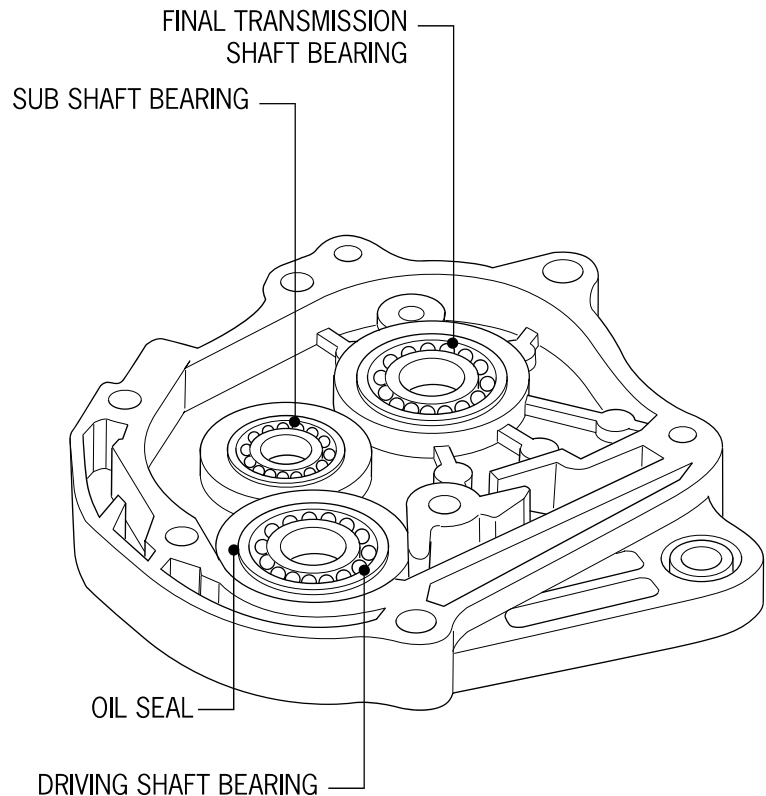

Replacing Bearing (on the side of the transmission gearbox cover)

1. Use a bearing puller to remove the bearing in the final transmission gearbox.

2. Remove the oil seal on the final transmission shaft.

3. Drive in the new bearing to the final transmission cover.

8. The Final Transmission Assembly

Replacing the Bearing (on the side of the crankcase)

1. Remove the driving shaft (the clutch main shaft). Then remove the oil seal of the shaft.
2. Use a bearing puller to remove the bearing in the final transmission gearbox.
3. Drive the new bearing into the final transmission gearbox. Install the new oil seal from the drive shaft.

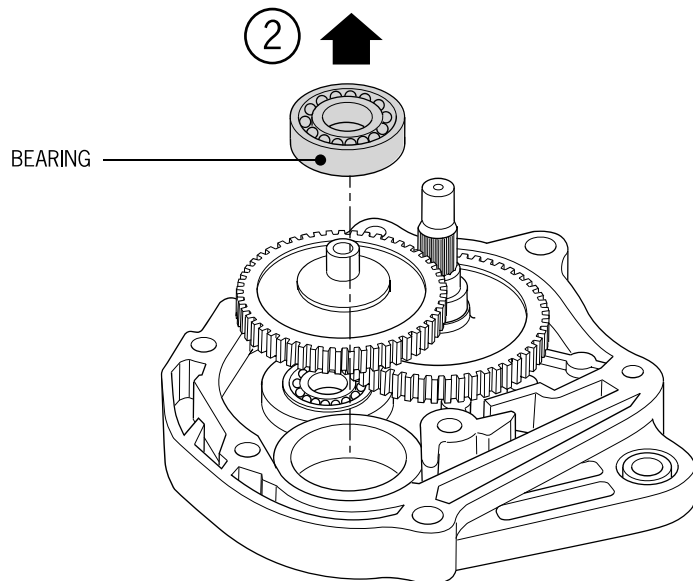
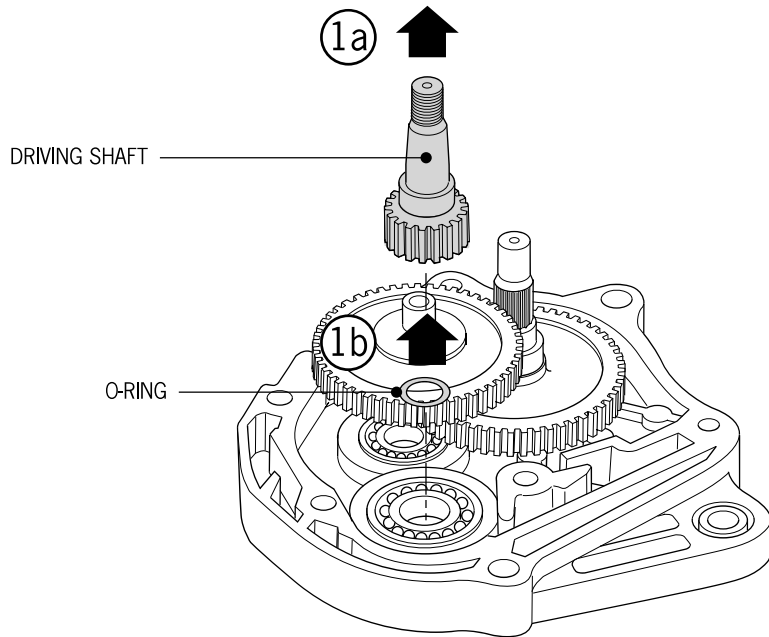

Assembling the Final Gear Set

1. First, install the drive shaft into the final gearbox. Then install the final transmission gear shaft (output shaft) to the final gearbox.

8. The Final Transmission Assembly

3. Attach the sub shaft and the washer to the final transmission gearbox. Install the resin washer to the sub shaft; install the locating pin and the new gasket.

4. Put on the final gearbox cover.

5. Tighten the bolts of the final gearbox cover.

6. Assemble the clutch/driving pulley disk (refer to 9-8).

7. After assembling, fill the gear box with 90w gear oil (refer to 3-7).

Designated gear oil: SAE 90#
Volume of the gearbox:
Filling: 0.12L 4 ounces
Changing: 0.10L 3.5 ounces

8. Screw up the oil screw and tighten it.

Torque: 1.0-1.4kg/m 8-10ft lbs

9. Start the engine to check if there is oil leakage.

10. Check the oil level. Replenish it with the designated gear oil when the oil is not sufficient (through the oil checking hole).

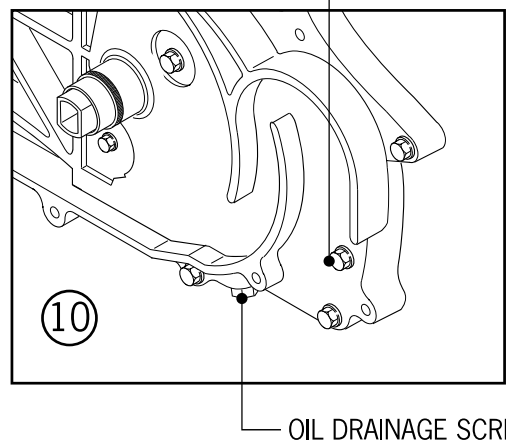
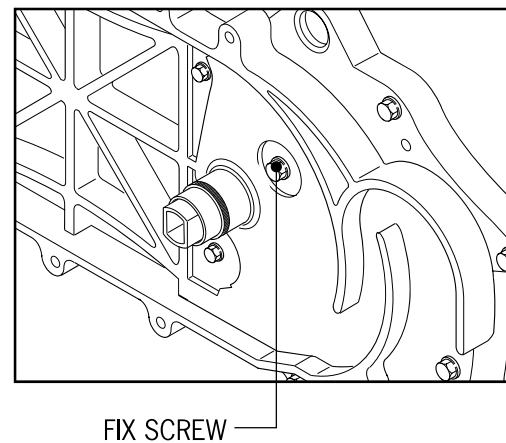
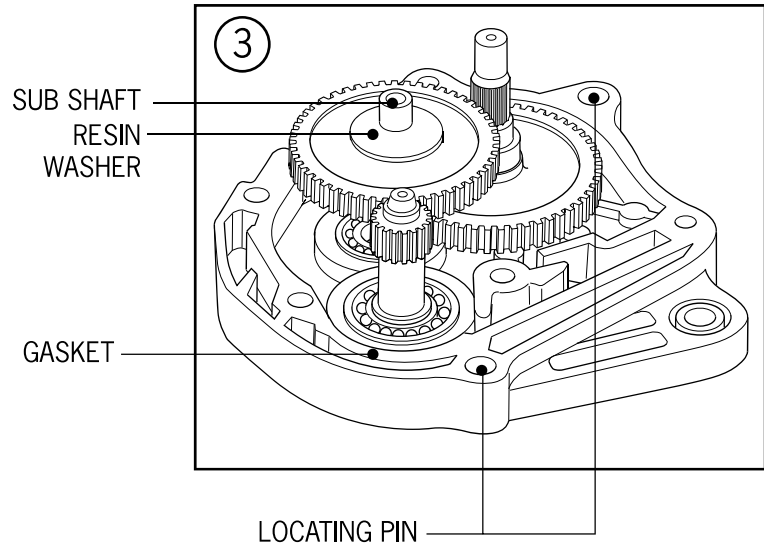

9. The Crankcase and the Crankshaft

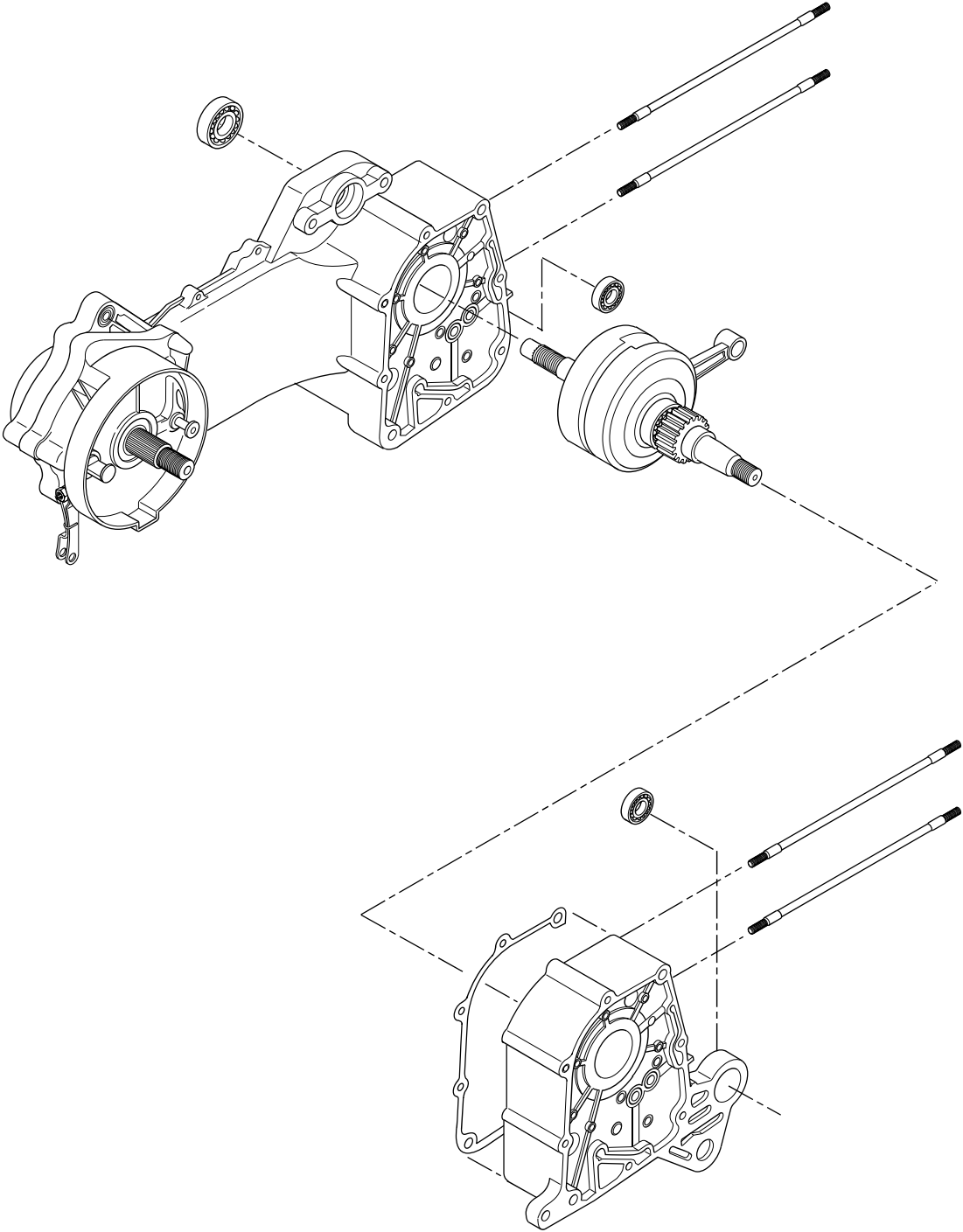

9. The Crankcase and the Crankshaft

Topic	Page
Important points	11-1
Diagnosis	11-1
Dismantling the crankcase	11-3
The crankshaft	11-4
Assembling the crankcase	11-5

Important Points

- The chapter gives instructions related to the crankshaft and dismantling the crankcase. Before striking, it's necessary to take the engine apart.
- Complete the following work before taking the crankcase apart. Remove the following:
 - The cylinder head (refer to Chapter 7)
 - The cylinder and the piston (refer to Chapter 8)
 - The driving plate and the driven plate (refer to Chapter 9)
 - AC generator (refer to Chapter 14)
 - The carburetor and the air filter (refer to Chapter 14)
 - The rear wheel and the rear buffer (refer to Chapter 13)
 - The starting motor (refer to Chapter 16)
 - The oil pump (refer to Chapter 4)

Tech Criteria

	Item	Normal size	Max. Service Allowance
Crankshaft	The clearance of the both sides of the big end of the connecting rod	0.10-0.35	0.55
	The clearance of X-Y directions of the journal of the big end of the connecting rod	0-0.008	0.05
	Run out		0.10

Torque:

Crankcase bolt 0.9kg/m 7ft lbs

Bolt for the chain adjusting guide lever cam 1.0kg/m 8ft lbs

Troubleshooting

Abnormal noise from the engine

- The crankshaft bearing is getting slack
- The crankshaft pin bearing is becoming loose

9. The Crankcase and the Crankshaft

Dismantling the Crankcase

1. Detach the bolt of the chain adjusting guide lever of the cam and remove the lever.
2. Remove assembly bolts of the crankcase.
3. Dismantle the right and left crankcases.

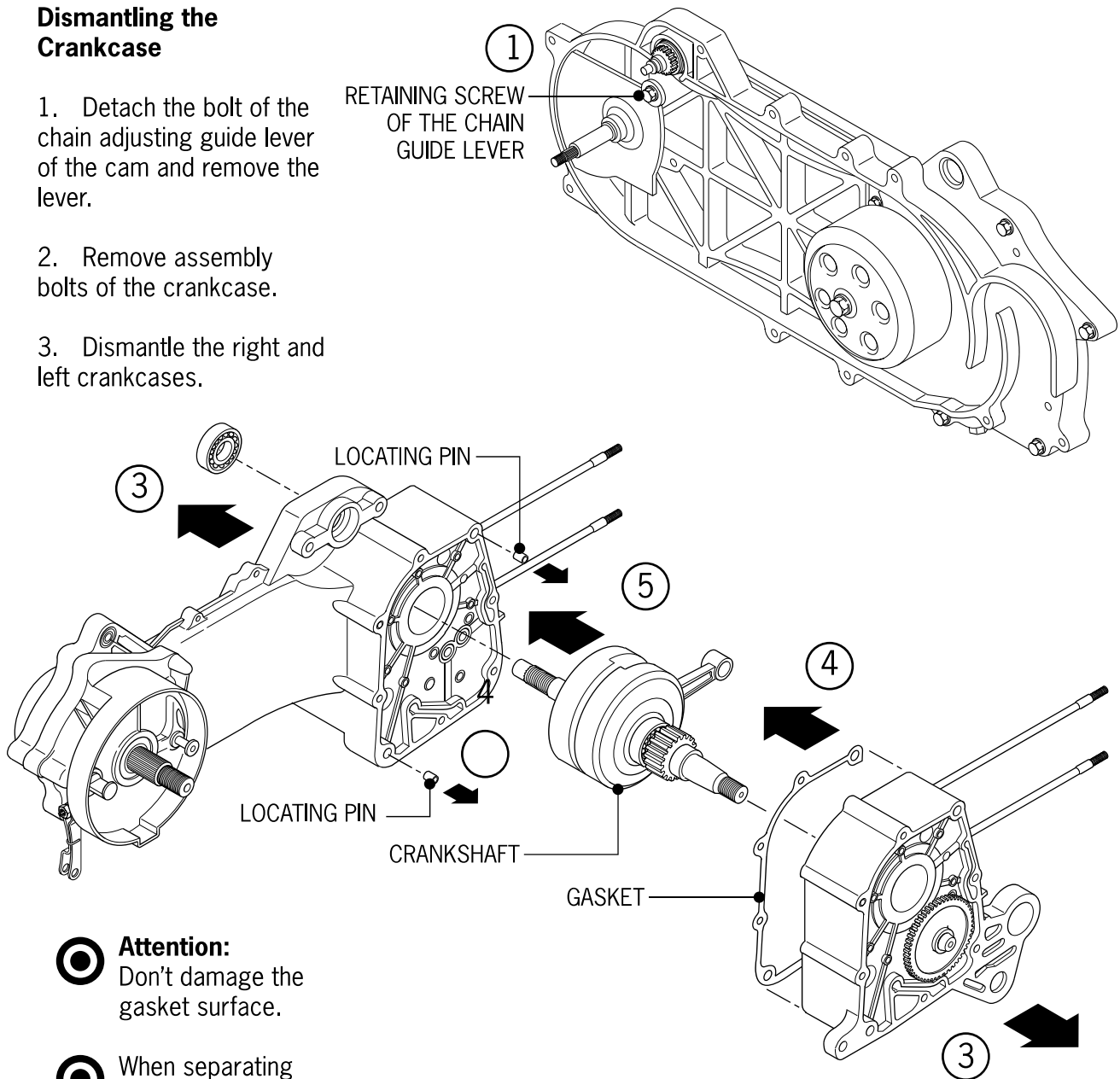

Attention:
Don't damage the gasket surface.

When separating the crankcases, don't use a screwdriver to pry them apart.

4. Remove the gasket and the locating pin.
5. Remove the crankshaft from the crankcase.

9. The Crankcase and the Crankshaft

7. Scrape the gasket away from the joint surfaces.

Attention: be sure not to scratch the joint surfaces.

8. Remove the oil seal from the left crankcase.

9. Remove the oil seal from the right crankcase.

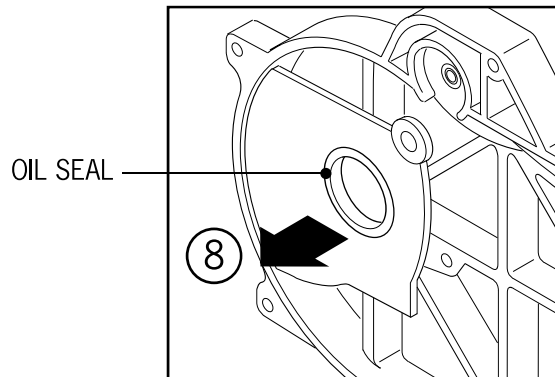

The Crankshaft

1. Measure the left and right clearance between both sides of the big end of the connecting rod.

*Maximum service allowance:
Replace when it goes beyond
0.55mm (.02 in.).*

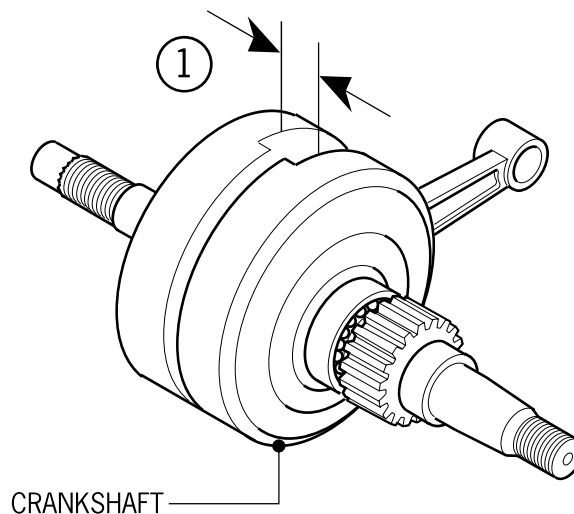

9. The Crankcase and the Crankshaft

2. Check the clearance of the journal of the big end of the connecting rod in X-Y directions.

*Maximum service allowance:
Replace when it goes beyond 0.05mm
(.002 in.).*

3. Measure the run-out of the crankshaft.

*Maximum service allowance;
Replace when it goes beyond 0.10mm
(.004 in.).*

4. Check if there is any abnormal noise and looseness when the crankshaft bearing revolves. Replace totally if any abnormal noise/looseness is detected.

Assembling the Crankcase

1. Use the following tools to install the oil seal of the crankcase:

- Bearing outer race driver
- Bearing outer race 32x35mm
(1.26 in. x 1.38 in.)

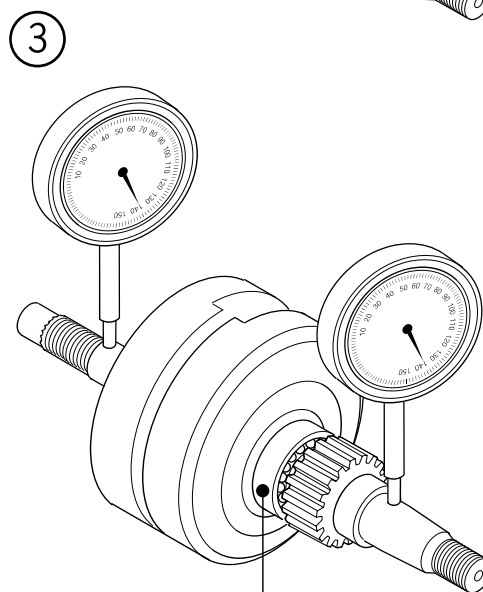
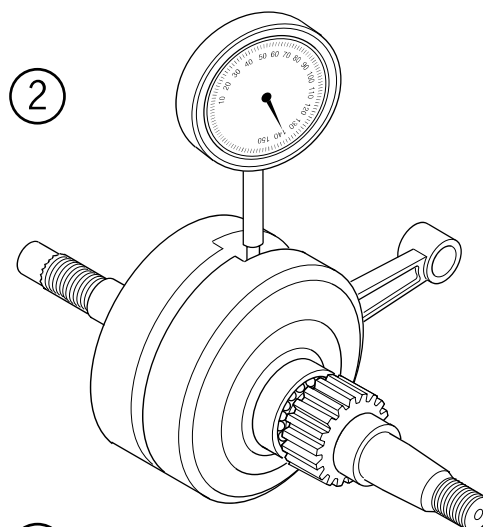

CRANKSHAFT
BEARING

9. The Crankcase and the Crankshaft

2. Install the cam chain into the left crankcase.
3. Assemble the crankshaft into the left crankcase.

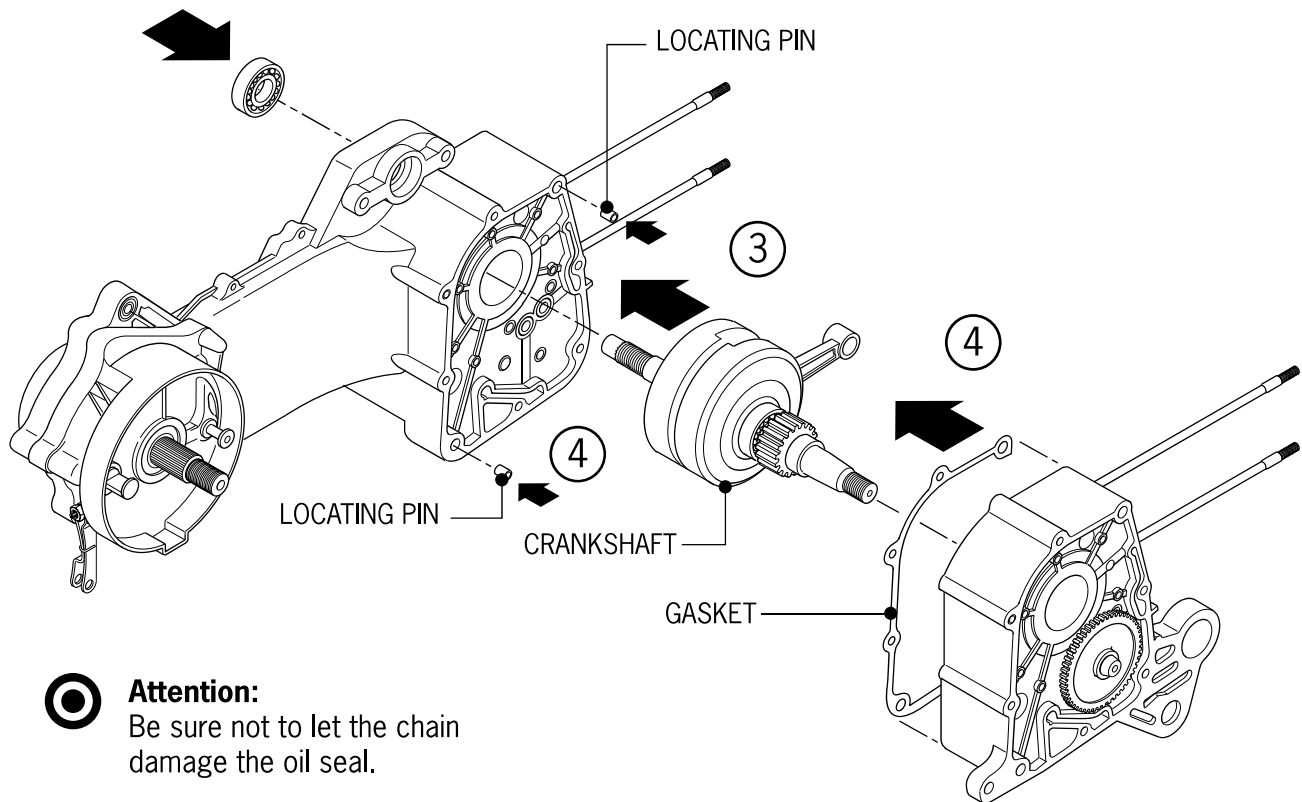

- ⦿ **Attention:**
Be sure not to let the chain damage the oil seal.

4. Put the new locating pin and the gasket onto the left crankcase.

- ⦿ **Attention:**
Keep the left crankcase downward to assemble with the right crankcase.

5. Tighten the bolts of the crankcase.

Torque: 0.9kg/m 7ft lbs

9. The Crankcase and the Crankshaft

6. Install the cam chain adjusting lever.
7. Install the o-ring onto the bolt of the chain adjusting lever.
8. Coat the o-ring with oil, and then lock it.

Torque: 1.0kg/m 8ft lbs

 Attention:
Be sure to put the o-ring into the groove.

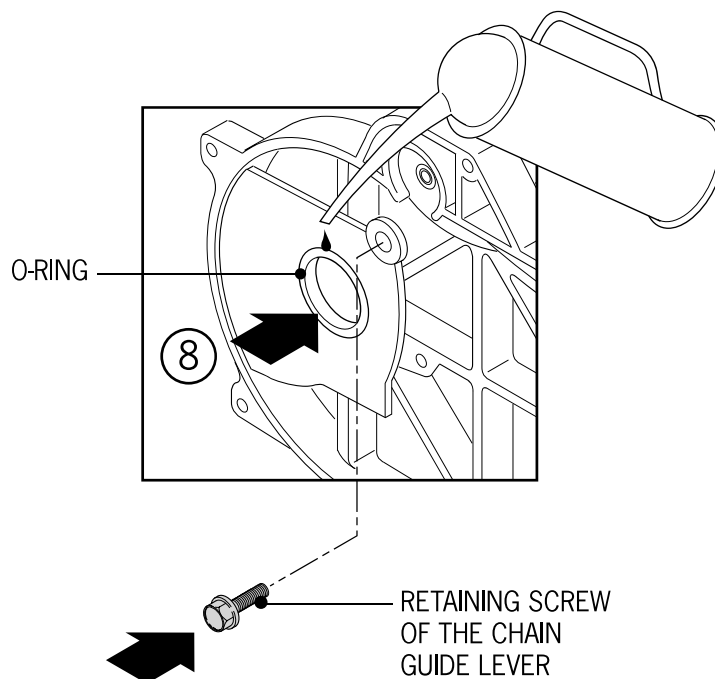

10. The Battery and the Charging System

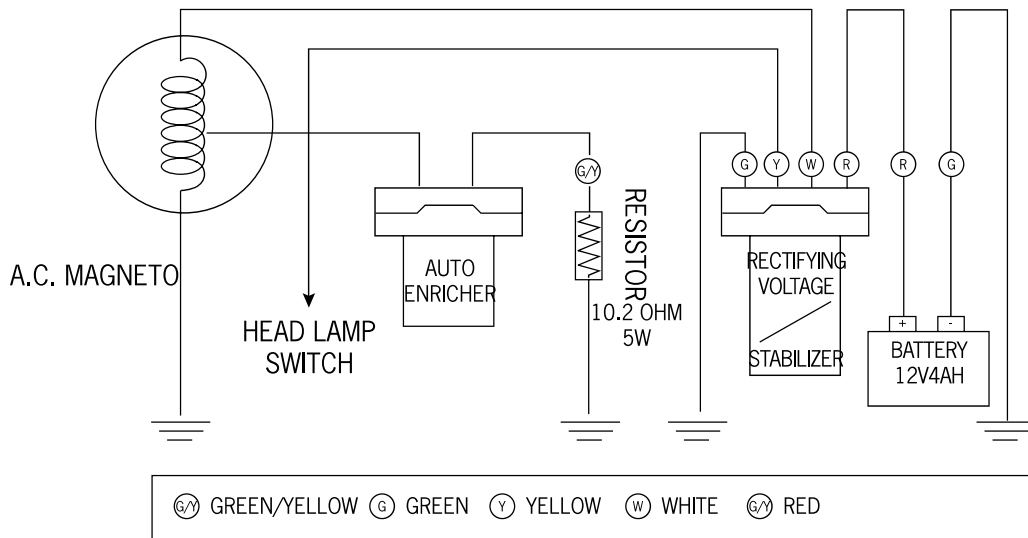
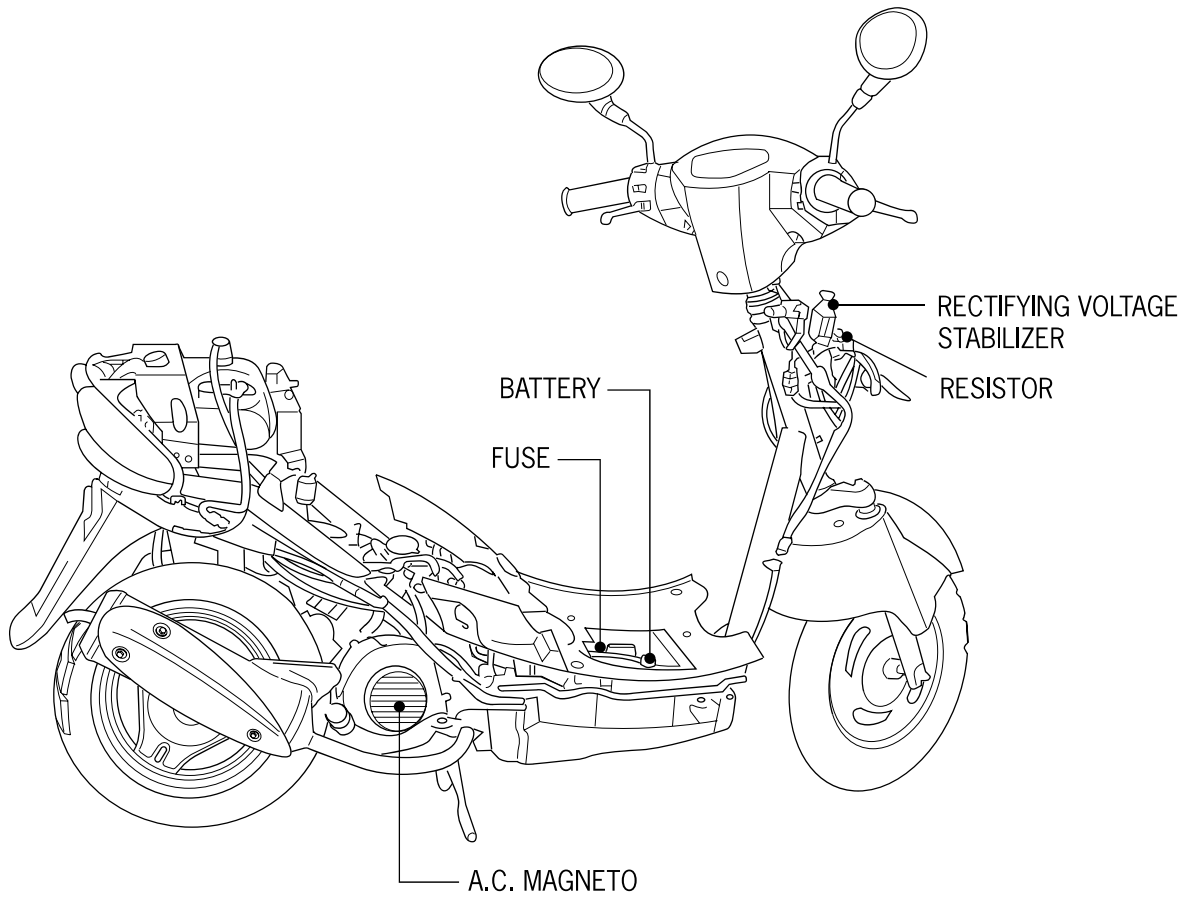

10. The Battery and the Charging System

Topic	Page	Topic	Page
Instructions	14-1	The Charging System	
Diagnosis	14-2	Testing short circuit	14-7
The battery	14-3	Assembling the magnetor	14-8
The charging system	14-4	The Magneto Charging Coil	14-9
The rectifying voltage stabilizer	14-5	Checking The magneto lighting coil	14-9
The magneto charging coil	14-6	Checking the Resistor	14-9
Checking the resistor	14-6	Dismounting the Magneto	14-9
Dismantling the magneto	14-6	Assembling the Magneto	14-11

Important Points

The electrolyte (diluted sulfuric acid) is very toxic. DO NOT allow acid to splash onto clothes, the skin or eyes to protect them from burning. Eye contact with acid may cause blindness. In case of contact with the acid, use a large amount of clean water to flush and rinse the areas in which the acid came into contact. See a Physician immediately. If the electrolyte acid gets into clothes, it will permeate to the skin. Remove tainted clothes immediately and then put them in water to rinse.

- The battery can withstand numerous cycles of charging and discharging as long as it is not left in a discharged condition for a long period of time.
- If the battery is overcharged, it can be detected by close inspection of the battery itself. If the battery is exposed to an extreme overcharged condition, it can break down and short circuit internally. In this condition, the battery will produce zero voltage under all load and charge conditions. An overcharged battery can “boil off” the electrolyte solution. This problem can be due to excessive time on a battery charger or a failed voltage regulator.
- If the scooter is left to sit for a long time or is stored, the battery will slowly discharge. It is advisable to recharge the battery before attempting to start the scooter after a period of storage.
- When filling a new battery with acid, allow it to sit and “breathe” for fifteen minutes before installing it into the scooter or charging it. It is advisable to charge a new battery after filling with acid even though it may appear to have sufficient charge.
- When working on the scooter’s electrical system, make sure that the main switch is turned off and/or the battery is disconnected. Disconnecting and reconnecting of live circuits can cause high instantaneous currents that can damage the battery and cause injury.
- Any short-circuiting of the wiring can cause damage to the battery.

10. The Battery and the Charging System

Tech Criteria

Item		Data	
Battery	Capacity/Type		12 V-4AH or 12V-5AH
	VOLT (20°C)	Fully charging	13.1V
		Low limit	12.3V
	Charging CUR		Standard: 0.4A; Fast: 2A
	Charging hours		Standard: 5-10 hrs; Fast 1hr
Magneto	Capacity		0.144KW/5000rpm
	Resistance of lighting coil (20°C)		Between yellow-clean 0.1-1.0 OHM
	Resistance of charging coil (20°C)		Between white-clean 0.2-1.2 OHM
Rectifying Volt Stabilizer	Type		Single phase, half-wave SCR charging; SCR half-wave short circuit mode
	Limited volt	Lighting	12-14/5000 rpm (multimeter, RPM meter)
		Charging	13.5 +/- 0.5V
	Resistance (20°C)		14.5 +/- 0.5V/3000-8000rpm
Resistance (20°C)		5W/4 OHM	
Resistor	Resistance (20°C)		30W/7.5 OHM

Torque

The bolt of the triggering coil 0.5kg·m 40in lbs
 The fix bolt of the coil 0.9kg·m 4ft lbs
 The fix bolt of the flywheel 3.8kg·m 25ft lbs
 The bolt of the cooling fan 0.9kg·m 7ft lbs

Tool

Universal fixing wrench
 Fly wheel puller
 Multi-meter

Diagnosis

No power supply

- Battery over-discharging
- Battery wiring improper
- Burnt fuse
- Broken electro switch lock

Unstable current

- Bad battery wiring contact
- Bad contact of discharging system
- Poor contact/short circuit of the lighting system.

Low voltage

- Improper battery charging
- Bad contact
- Poor charging system
- Damaged rectifying volt stabilizer

Poor charging system

- Bad contact, breaking or short circuit of the wiring connector
- Poor rectifying stabilizer
- Damaged magneto

10. The Battery and the Charging System

Detaching the Battery

1. Remove the screws of the battery cover under the floor mat.
2. Open the cover and remove the battery cable attachment screws.

Attention:
First detach the negative (-) terminal wire, then the (+) terminal wire. When detaching the positive (+) terminal wire, make sure that the tool does not contact the frame.

3. When assembling, operate in the opposite sequence of dismounting.

Attention:
In order to prevent short circuiting, first connect the (+) terminal wire, then the negative (-) terminal wire

Checking the charging condition (open circuit volt)

1. Open the battery cover and disconnect the battery.
2. Measure the voltage across the terminals of the battery.

Fully charged: 13.1V
Inadequately charged: 12.3V

Attention:
Use a volt meter to check the charging condition.

Charging

1. Connect the (+) terminal pole of the charger to the (+) terminal pole of the battery and the negative (-) terminal pole of the charger to the negative (-) terminal pole of the battery.

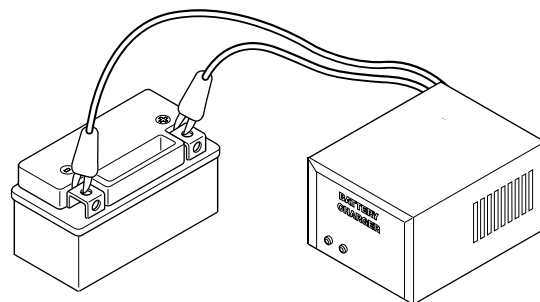
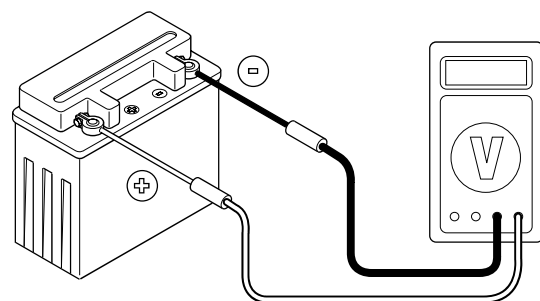
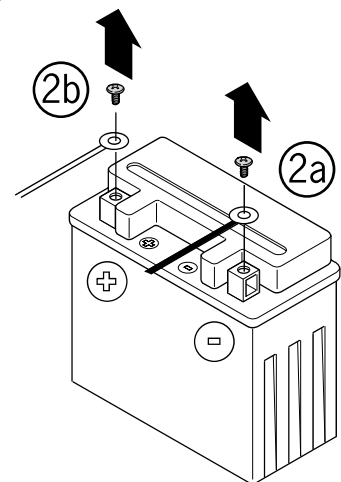
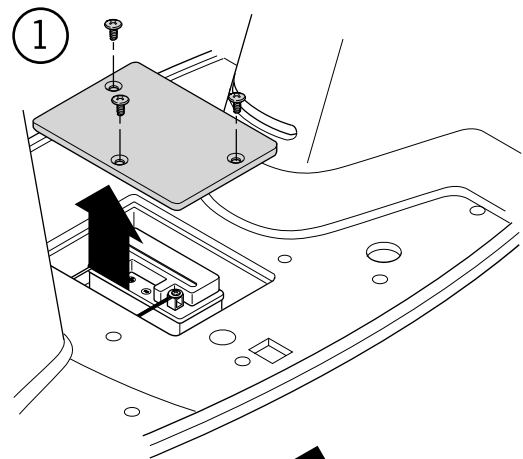

10. The Battery and the Charging System



Attention:

- No sparks should be allowed around the battery.
- Turn off the charger first, either at the beginning or the end of the charging, to prevent sparks, which can cause an explosion.
- When charging, operate at the current and time marked on the battery.
- Unless in an emergency situation, do not use fast charging.
- Measure the voltage only 30 minutes after charging.

Charging current:

Standard 0.4A

Fast: 2A

Charging Hours:

Standard: 5-10hrs

Fast: 1hrs.

When charging ends:

Open-circuit voltage: above 12.8V

Note: During charging, the temperature of the battery is not allowed to go beyond 45°C (110°F).

10. The Battery and the Charging System

The Charging System

Testing short circuit

1. Detach the earth wire from the battery.
2. Connect the ammeter between the "-" terminal of the battery and the earth wire, the main switch being in the "off" position to check whether it's short-circuited.



Attention:

The (+) terminal of the multi-meter is connected to the "-" pole of the battery, while negative (-) terminal wire of the multi-meter is connected to the earth wire.

3. When an abnormal sign appears, check if there is a short circuit in the main switch and the main cable.

Checking the Charging Condition

1. When the battery is in full charging condition, use a multi-meter to test.
2. After the engine is warmed up, install the fully-charged battery. Connect the voltmeter across the terminals of the battery.
3. Remove the main fuse and connect the ammeter between the terminals.
4. Connect the RPM meter to the engine.
5. Start the engine, when the speed of the engine slowly rises, measure the charging voltage and current.

Limiting Voltage/Current:

Below 14-15V 0.5A (Below 5000rpm)

When the limiting voltage goes beyond the above scope, check the rectifying voltage stabilizer (refer to 14-5).

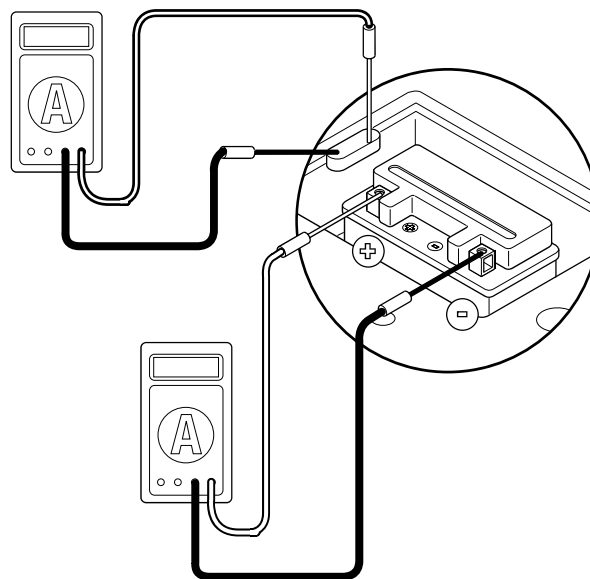
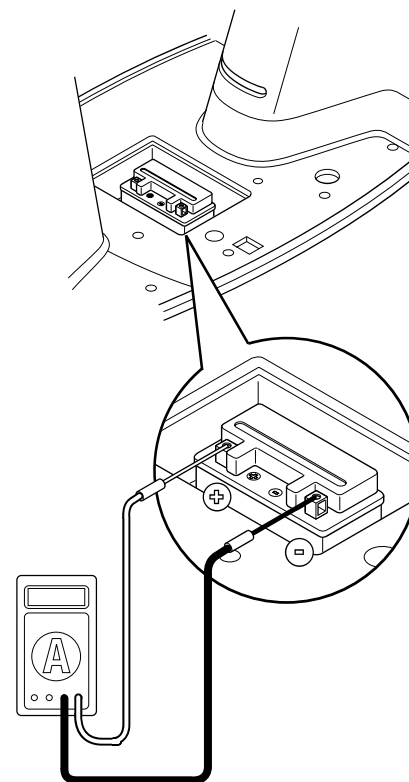

Switch Position	OFF	P	H
RPM			
2500	>1.0A	>1.0A	>1.0A
5000	>1.5A	>1.5A	>1.5A

10. The Battery and the Charging System

The rectifying voltage stabilizer

1. Checking the main cable circuit.
2. Detach the 4P plug from the rectifying voltage stabilizer.
3. Check the conductivity between terminals of the main cable in the following way:

Item (matching color wire)

Checking the Rectifying Voltage Regulator

1. After the main cable has been tested and found normal, check the plug of the rectifying voltage stabilizer contact well and measure the resistance among the terminals of the regulator.



Attention:

Make sure that your finger doesn't touch the metal part of the test bar of the multi-meter because the human body has resistance.



Use a multi-meter to test.



Test positions per chart.

2. When the resistance among the terminals is abnormal, replace the rectifying voltage stabilizer.

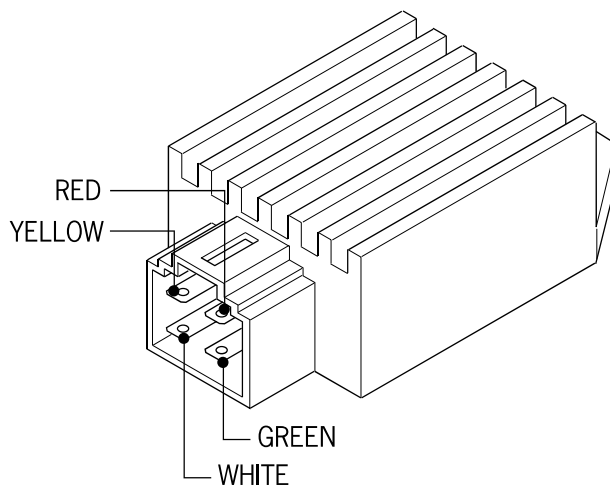
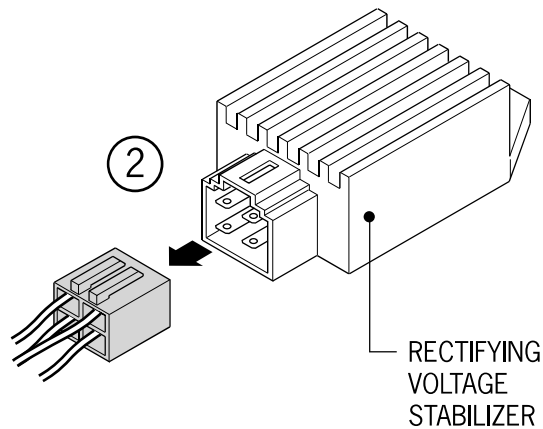

Multimeter + - + -	White	Yellow	Red	Green
White	∞	∞	3K-50K	∞
Yellow	∞	∞	∞	5K-100K
Red	∞	∞	∞	∞
Green	∞	5K-100K	∞	∞

10. The Battery and the Charging System

The Magneto Charging Coil

- ⦿ **Attention:**
This operation of the magneto charging coil can be accessed within the engine.

Checking

1. Detach the connecting plug of the magneto.
2. Use a multi-meter to measure the resistance between the white wire of the magneto and the ground.

Criterion: 0.2-1.2 OHM (20°C)
When the value goes beyond the criterion, replace the magneto coil.

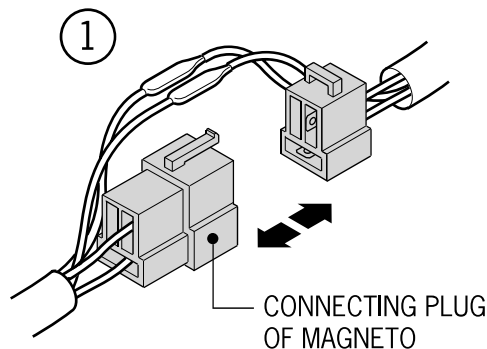

Checking The magneto lighting coil

- ⦿ **Attention:**
This operation of the lighting coil can be accessed within the engine.

1. Detach the connecting plug of the magneto.
2. Use a multi-meter to measure the resistance between the yellow wire and the ground.

Criterion: 0.1-1.00HM (20°C)
When the value goes beyond the criterion, replace the magneto coil.

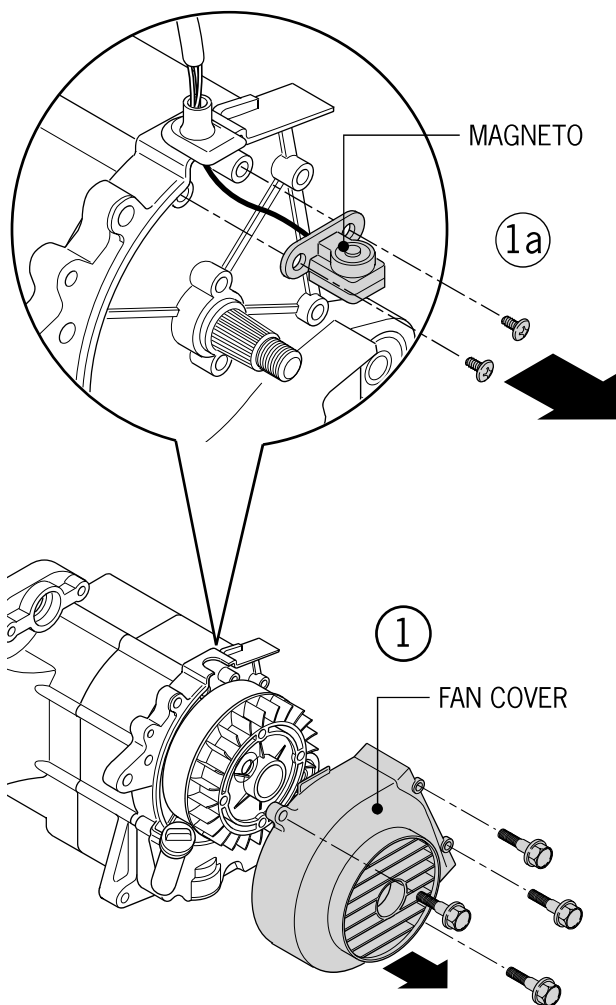

Checking the Resistor

1. Measure the resistance between the resistor wire and the ground.

Criterion: 30W7.5 OHM : 6.0-9.0 OHM
5W14 OHM : 13-15 OHM

Dismounting the Magneto

1. Detach the right side guide strip (refer to 2-3)
Remove the four bolts, four screws and remove the fan cover.

10. The Battery and the Charging System

3. Remove the four bolts and remove the cooling fan.

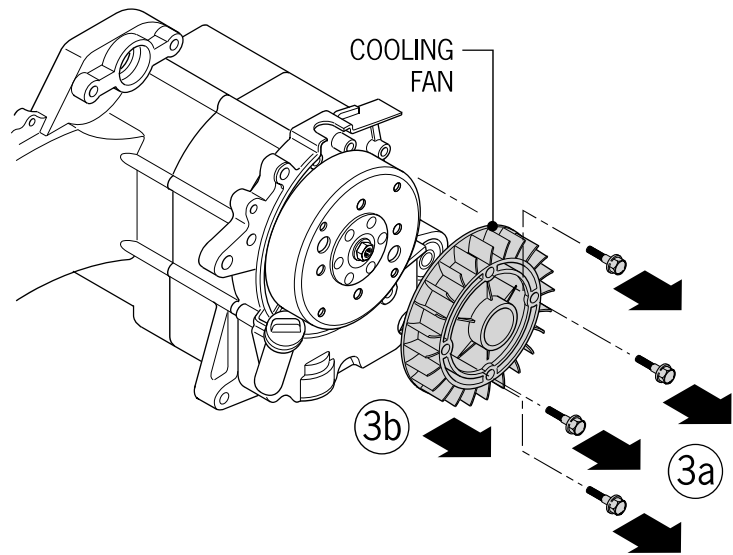

4. Use a universal solid wrench to secure the flywheel. Detach the fix nuts of the flywheel.

5. Use a spanner wrench hold flywheel while removing the retaining nut.

6. Use a flywheel puller to remove the flywheel.

7. Remove and save the key.

8. Detach the connecting wire of the magneto.

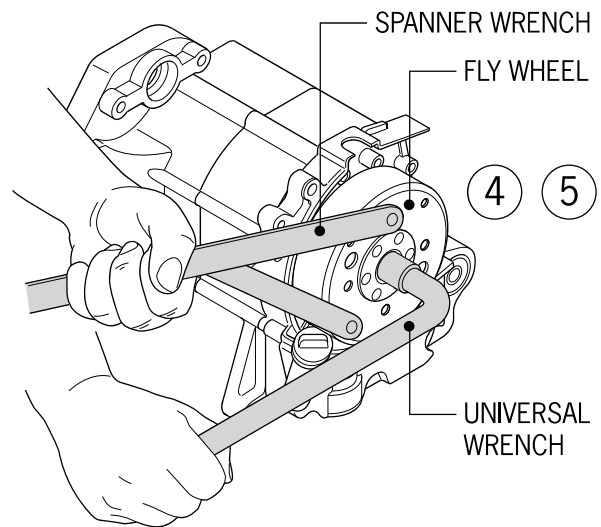

10. The Battery and the Charging System

3. Detach the stator of the magneto.
4. Remove the bolts of the triggering coil.
5. Remove the rubber sleeve of the magnetor wire from the right crankcase.
6. Remove the triggering coil.

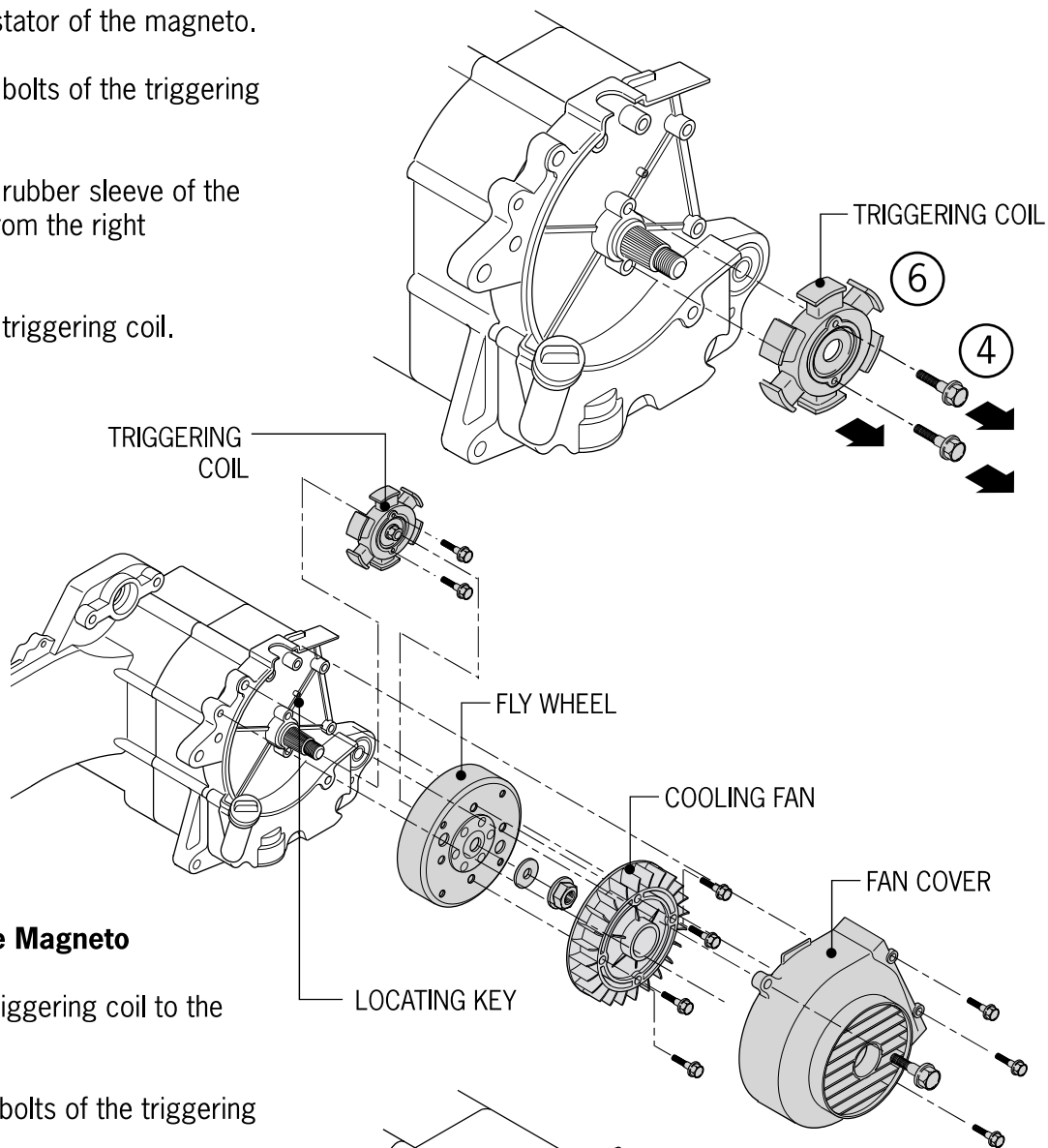

Assembling the Magneto

1. Attach the triggering coil to the right crankcase.
2. Lock the fix bolts of the triggering coil.

Torque:
The triggering coil: 0.5kg•m
40in lbs
The stator: 0.9kg•m 7ft lbs

3. Set up the rubber sleeve of the magneto wire.

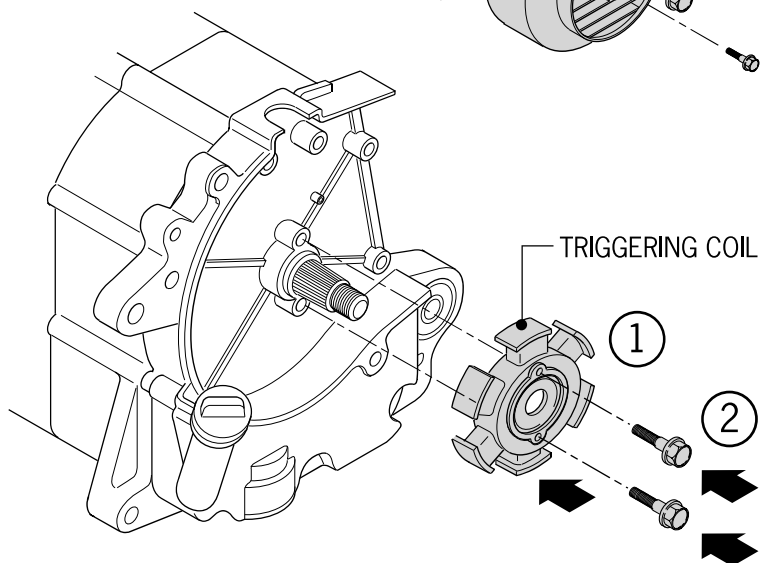

10. The Battery and the Charging System

4. Connect the connecting wire of the magnetor.

5. Clean the cone part of the crankshaft and of the flywheel. Be sure to lay the locating key of the flywheel into the keyway on the crankshaft precisely. Point the groove of the flywheel to the locating key on the crankshaft and then assemble it.

Attention: Make sure that there is no bolt/nut inside the flywheel, and then assemble it.

6. Use a universal solid wrench to hold the flywheel, and then lock the nut.

Torque: 3.8•m

7. Set up the cooling fan

Torque: 0.9kg•m

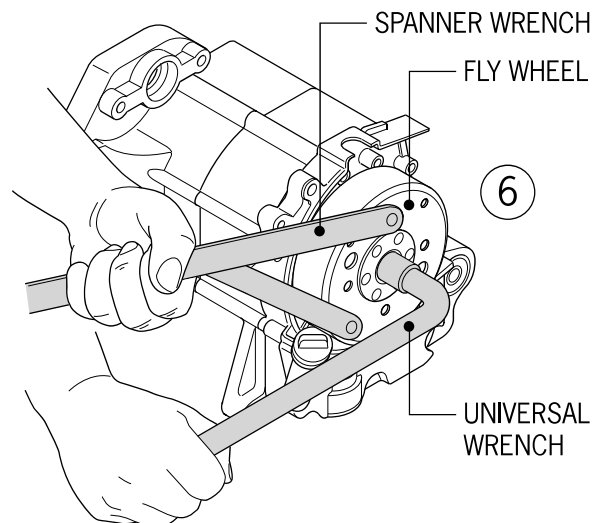
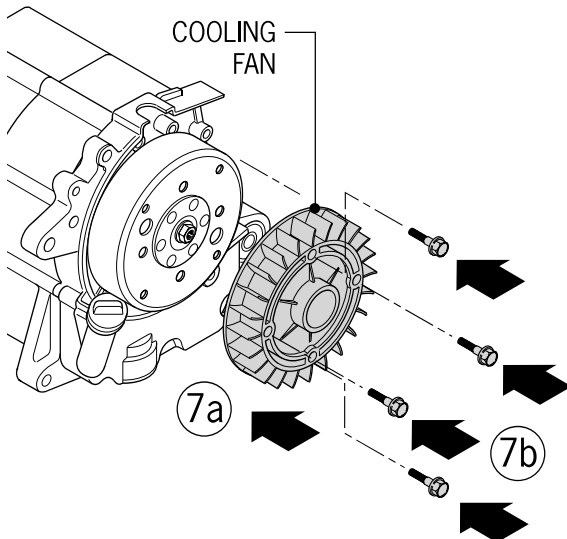
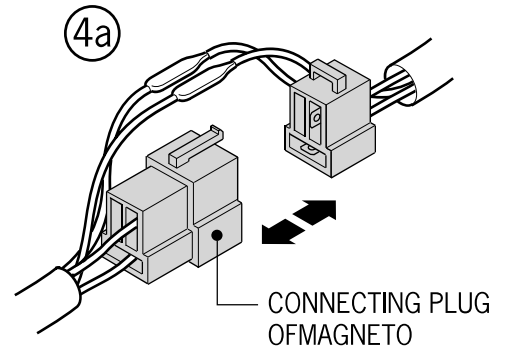
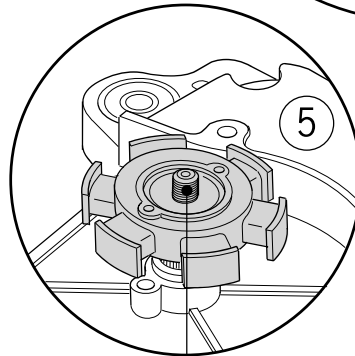
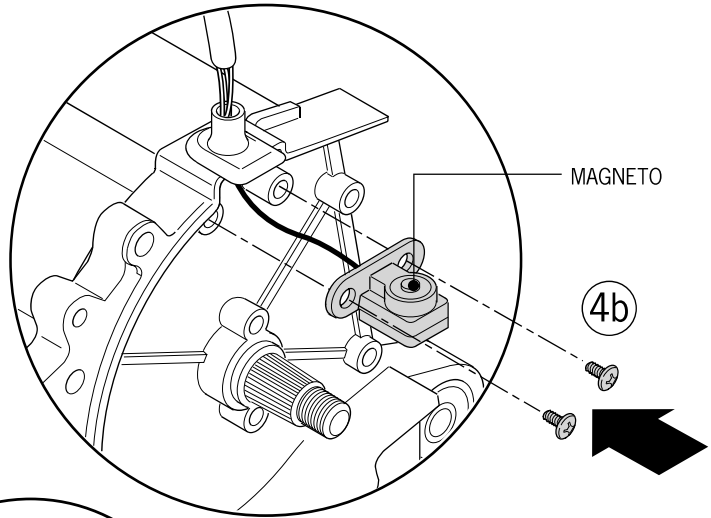

10. The Battery and the Charging System

8. Install the fan cover and securely tighten fasteners.

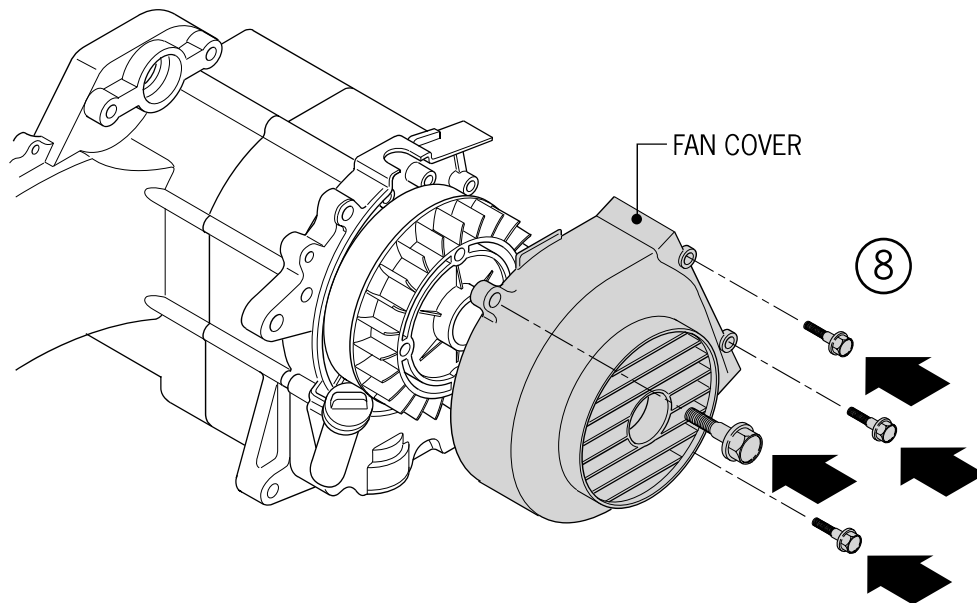

11. Ignition System

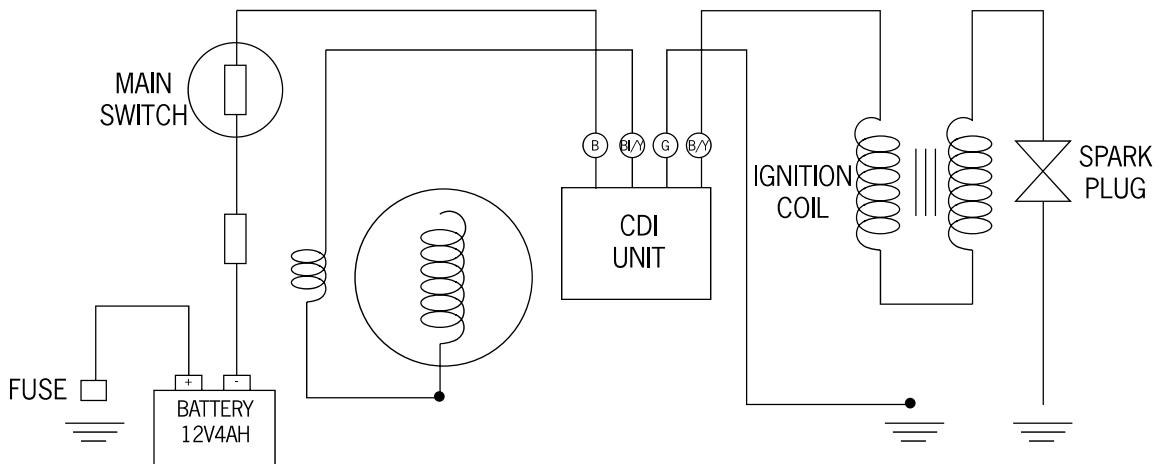
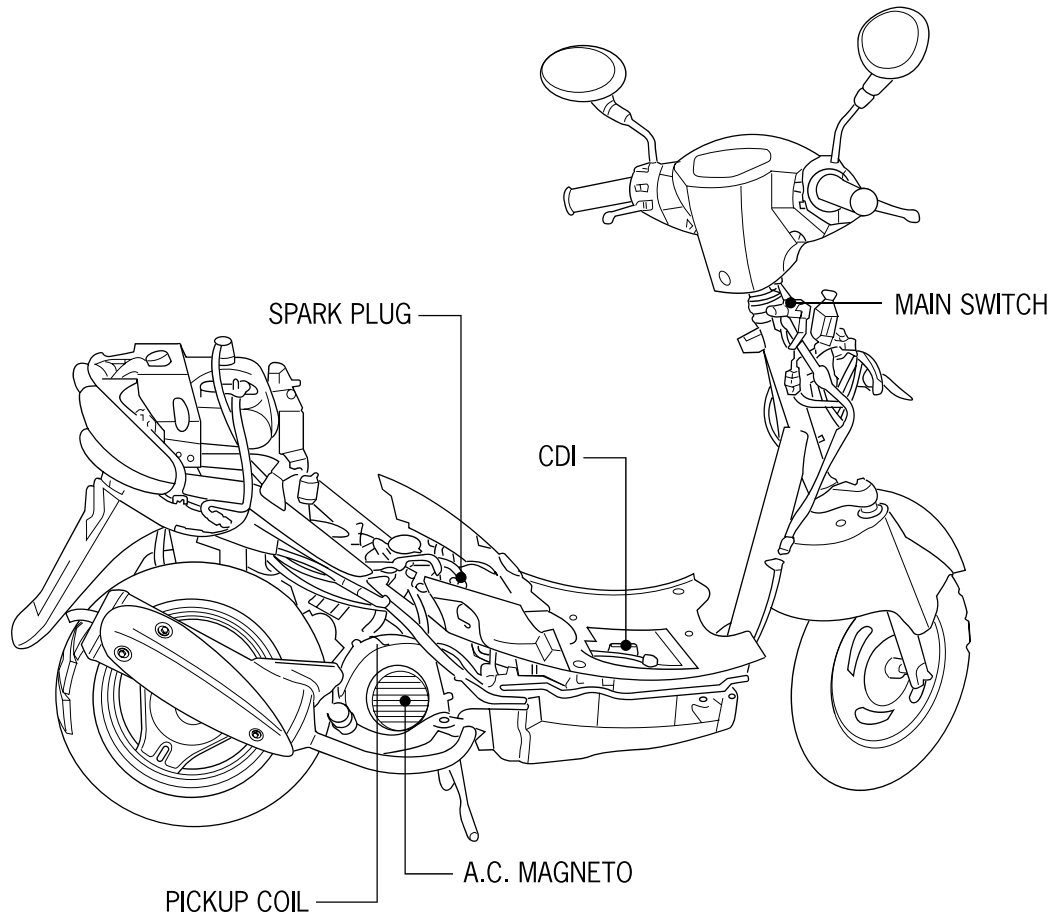

B BLUE
 B/Y BLUE/YELLOW
 BY BLACK/YELLOW
 G GREEN

11. Ignition System

Topic	Page
General Information	15-2
Troubleshooting	15-3
CDI unit inspection	15-4
Ignition Coil Removal Steps	15-5
Magneto Pickup Coil Inspection	15-6
Spark Advance Angle Inspection	15-6

General Information

- Check ignition system in accordance with the troubleshooting procedure in Section 15-2.
- As the ignition system has an electric automatic spark control in the CDI unit, there is no need for spark advance angle adjustment.
- CDI should not be disconnected or subjected to input. Damage or failure can occur.
- Poor contact may be the cause of many faulty ignition system cases. Check all terminal connections to be sure they are clean and tight whenever troubleshooting an electrical problem.
- Make sure spark plug heat range is correct. Using an incorrect spark plug will result in improper engine operation or spark plug damage.
- Peak voltage is used as reference point in tests. Record coil resistance tests.
- When inspecting spark plug, refer to related instructions in Chapter 3.
- When removing AC generator and pickup coil, refer to instructions in Chapter 14.

Reference Standard

Item			Standard valve
Specific spark plug	Standard		(NGK)C7HSA Champion Z9Y
	Hot		(NGK)C6HSA
	Cold		(NGK)C8HSA
Spark plug gap			0.6-0.7mm
Spark advance angle	Maximum advance in "F" position		13° +/- 1° (2000r/min)
Ignition coil resistance	Primary coil		0.1-1.0 OHM
	Secondary coil	With cap	7-9K OHM
		Without cap	3-4K OHM
Pickup coil resistance			1-10 OHM
Primary ignition coil peak voltage			Over 120V
Pickup coil peak voltage			Over 2.1V

11. Ignition System

Troubleshooting

High Tension Voltage Too Low

- Crankshaft revolution too slow or battery voltage too low
- Ignition system wiring loose
- Faulty ignition coil
- Faulty CDI unit
- Faulty pickup coil

High Tension Voltage Intermittent

- Faulty main switch
- Poor CDI terminal connection
- Poor CDI ground
- Faulty pickup coil
- Poor high-tension lead terminal connection
- Faulty CDI unit

High Tension Voltage Normal but No Spark

- Faulty spark plug
- Faulty spark plug cap

No High Tension Voltage

- Faulty main switch
- Battery discharged or faulty rectification system
- Faulty charge system
- Faulty ignition coil
- Faulty CDI United Equine Foundation No

Intermittent High Tension Voltage

- Faulty ignition coil
- Battery voltage too low
- Faulty charge system

1 1. Ignition System

CDI Inspection

1. Remove the three screws from the battery case cover.
2. Disconnect the CDI module from the wire harness.
3. Test resistance of the terminals with a multi-meter.



Attention:

Since there is a semiconductor in return circuit, testing results may be significantly different if different multi-meters are used.



If the pointer on the dial flickers and finally stops during testing, it should be regarded as normal. Because the capacitor in the CDI module is charged while being tested, it cannot discharge.

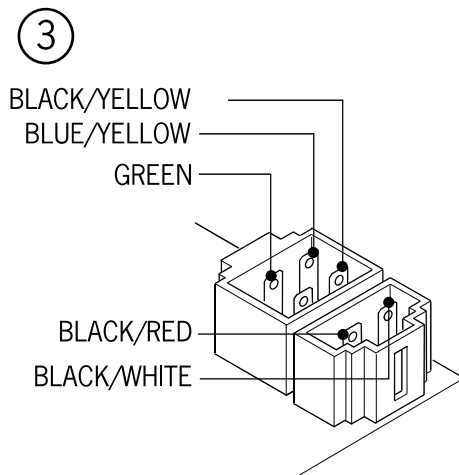
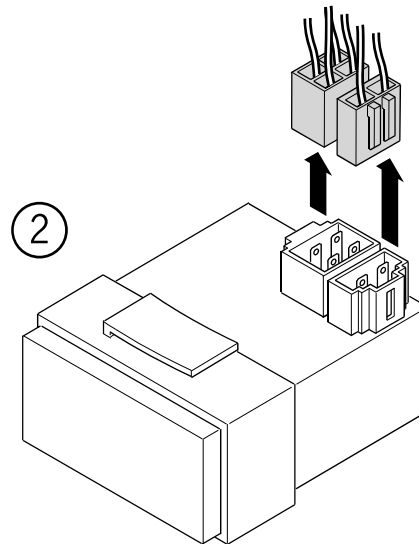
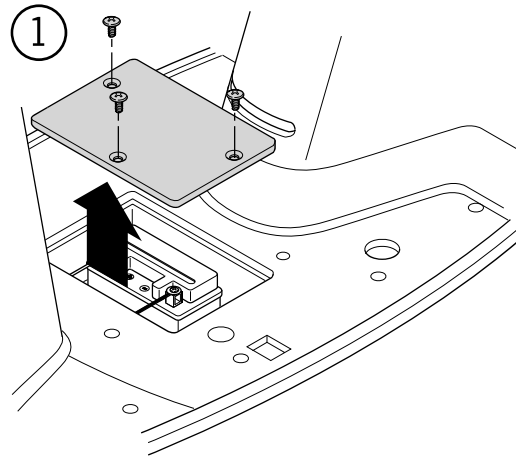

11. Ignition System

Ignition Coil Removal Steps

1. Remove the middle box.
2. Remove the spark plug cap.
3. Disconnect the wires, remove the ignition coil jam nuts and remove the ignition coil.
Inspection

4. Check the ignition coil circuit. The spark advance angle does not need to be adjusted.

If the spark advance is abnormal, check the CDI, pickup coil or magneto. Replace the ignition coil if necessary.

5. Test the primary coil resistance, the standard value of which should be $0.1-1.0\Omega$.

6. Test the secondary coil resistance from spark plug cap negative terminals. The standard value should be $7-9k\Omega$ (with cap) and $3-4k\Omega$ (without cap).

7. Test coil using after-market spark tester.

8. Perform the following inspection in accordance with the operating instructions in the manual.

- a. Set the ignition coil tester switch to 12V and connect the tester to the ignition coil.
- b. Turn the switch to the ON position to check spark frequency from the inspection door.

In good condition: Sparking continuously

In faulty condition: Sparking abnormally.

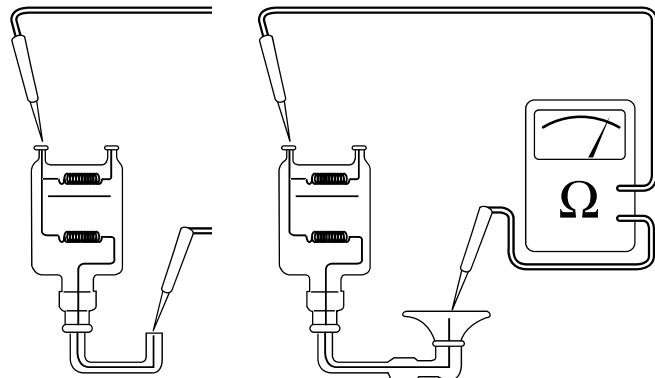
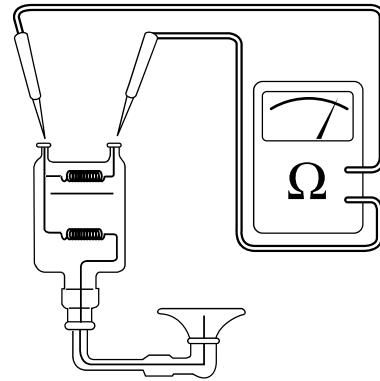

11. Ignition System

Magneto Pickup Coil Inspection

⦿ This test is to be conducted with the stator mounted in the engine.

1. Remove the fan cover.
2. Disconnect the magneto.
3. Test the pickup coil resistance between the blue/yellow and green lead terminals whose standard value is 80-160.
4. Dismounting the magneto (refer to 14-6).

Charging Coil Inspection

1. Test the charging coil resistance between the black/red and the green lead terminals whose standard value is 500-600 .

Spark Advance Angle Inspection

- ⦿ Since a CDI is used, there is no need to adjust the timing advance.
- ⦿ If the spark advance is abnormal, inspect CDI, pickup coil or magneto. Replace if necessary.

3. Remove timing lid.
4. After the engine is warmed up, check the spark advance angle by the spark timing lamp. It is proper for "F" to align with + 2° with the engine revolving at a speed of 1700rpm.

The spark advance angle should be $13^{\circ} + 1^{\circ}$ (2000r/min).

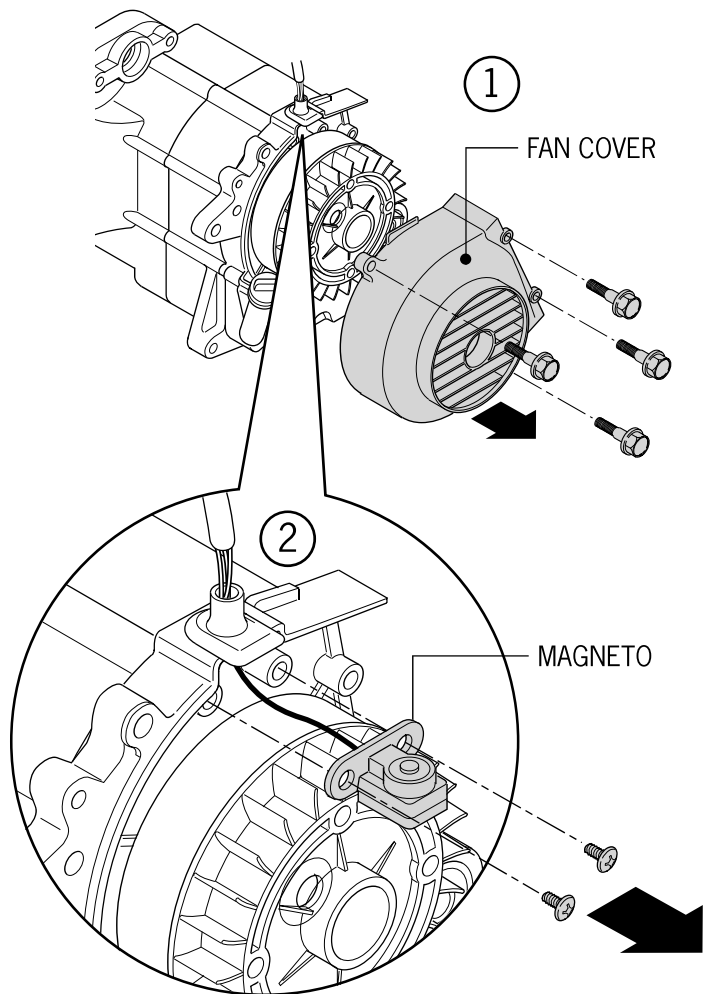

12. Starter System

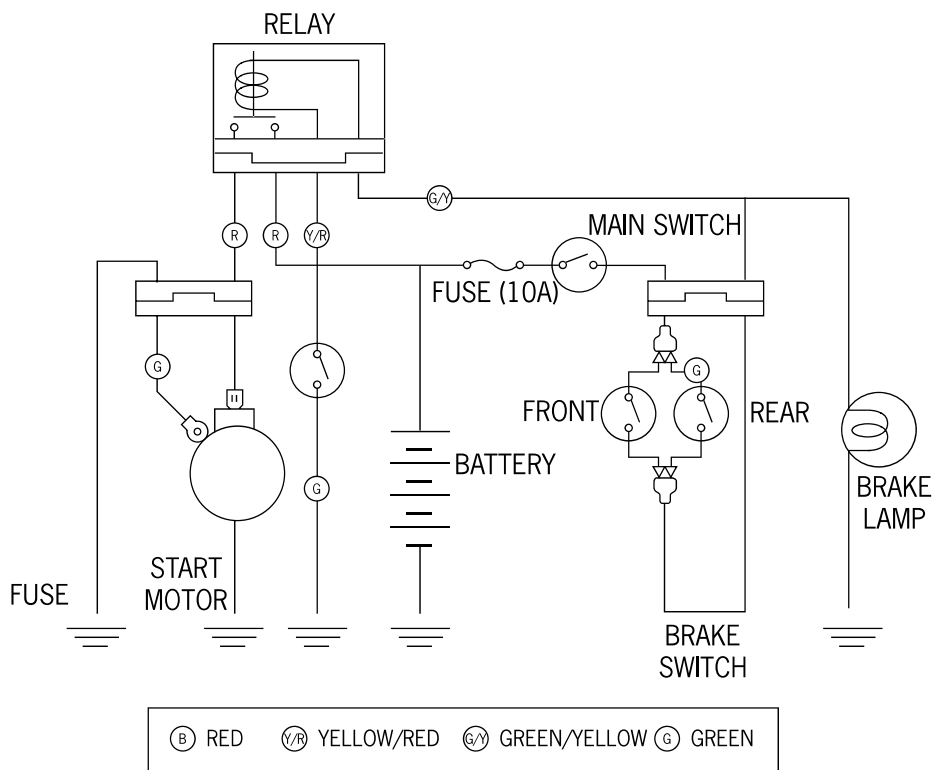
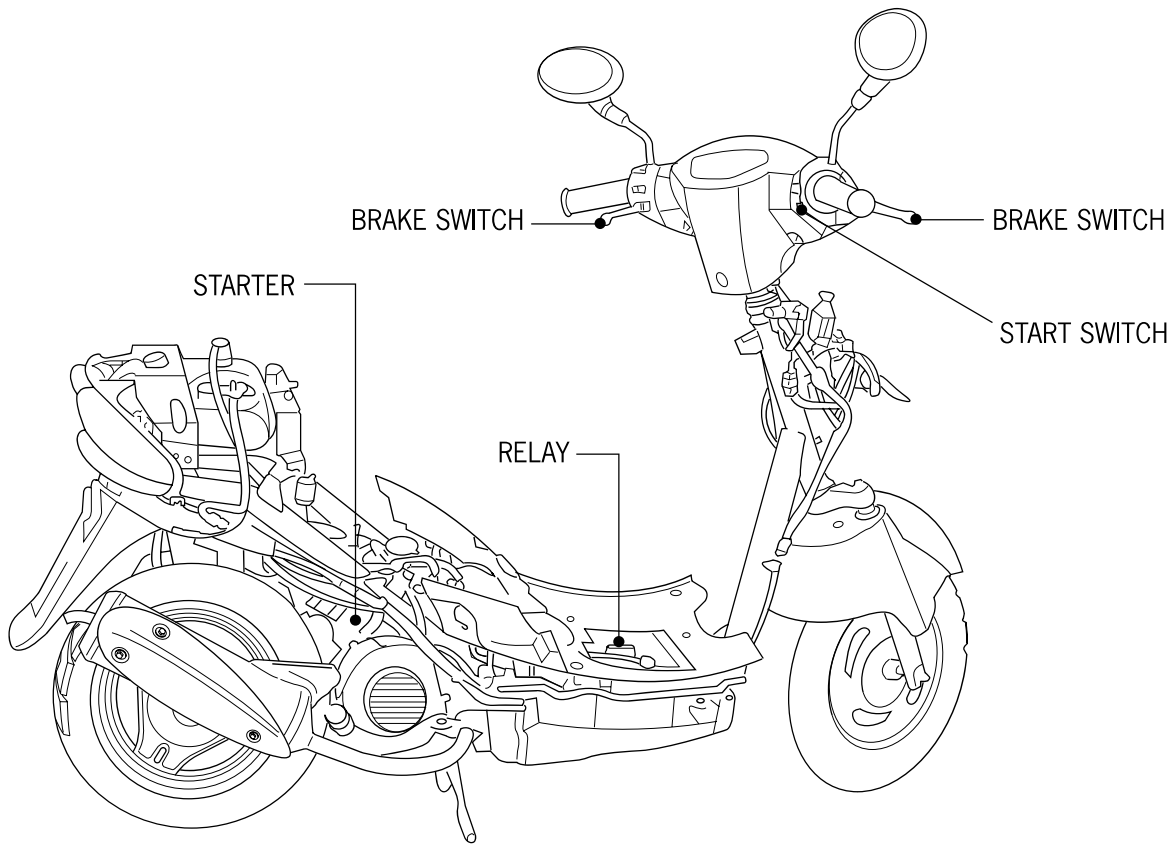

12. Starter System

Topic	Page	Topic	Page
General Information	16-2	Starter Motor Inspection	16-6
Troubleshooting	16-2	Starter Motor Installation	16-6
Starter Motor Removal	16-3	Starter Pinion Removal	16-7
Starter Disassembly	16-3	Starter Pinion Inspection	16-7
Starter Inspection	16-3	Starter Pinion Installation	16-7
Inspecting the Starter Relay	16-5		

General Information

- The starter motor can be removed without disassembly of the engine.

Installation Reference Standard

Item	Standard valve	Wear Limit
Starter motor brush length	8.5 mm (.335 in.)	5 mm (.2 in.)

Fastener Torque Specification

Starter motor clutch cover bolt

1.2kg-m 8-9 ft lbs

Starter motor clutch jam nut

9.5kg-m 65-68ft lbs



Hex key



Open end wrenches

Troubleshooting

Starter Motor Does Not Turn

- Fuse broken
- Battery discharged
- Faulty main switch
- Faulty starter clutch
- Faulty brake switch

Starter Motor Turns Over Slowly

- Battery discharged
- Poor or faulty cable connections
- Starter motor gear seized by a foreign object

Starter Motor Turns – Engine Does Not Rotate

- Faulty starter clutch
- Starter motor reversal
- Battery discharged

12. Starter System

Starter Motor Removal

⊙ Never work on the starter motor until main switch is turned off and the battery ground wire is disconnected to ensure that the motor cannot turn.

1. Remove the starter motor lead clamp.
2. Remove the two bolts and remove the starter motor.
3. Roll up the water-proof rubber cover to disconnect the starter motor.

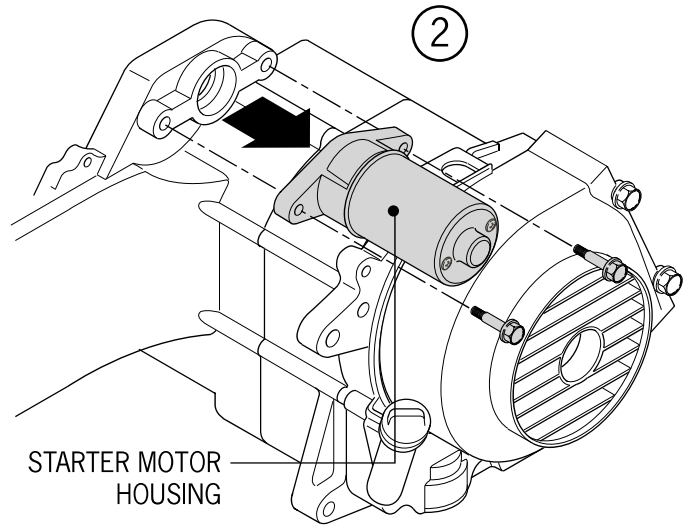

Starter Disassembly

1. Remove the two case bolts and remove the motor housing from the internal parts.

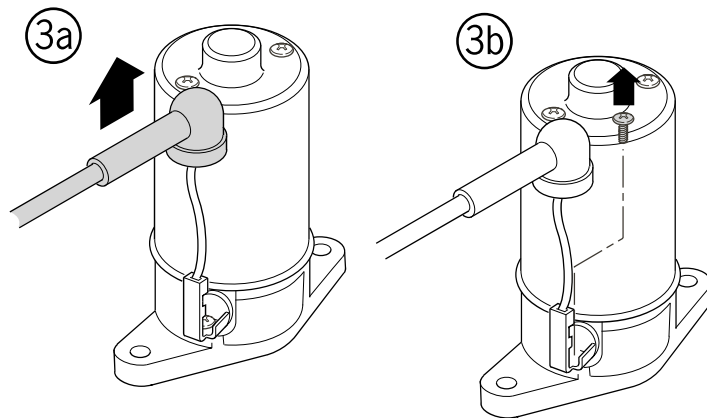

Starter Inspection

2. Inspect brushes and commutator for wear, damage or discoloration. Replace if necessary.
3. Clean attached metal particles from the commutator surfaces.
4. Measure the resistance between each contact surface of the components.
5. Make sure there is no conduction current between each commutator segment and the armature shaft.

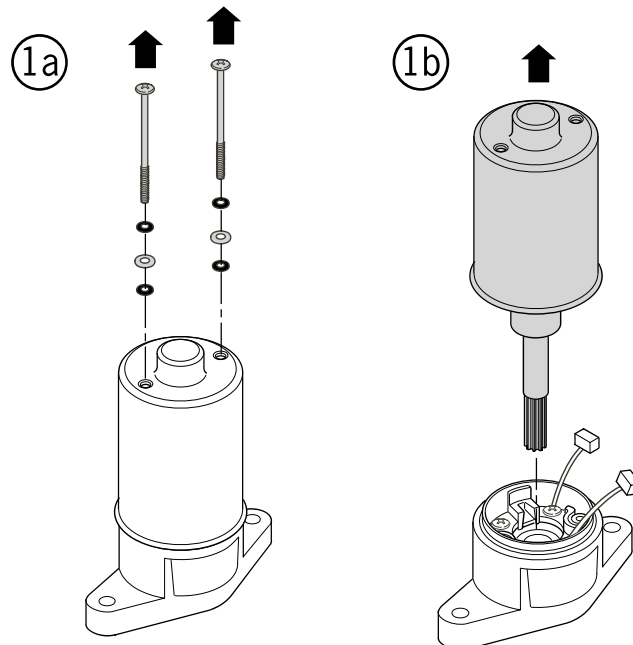

12. Starter System

6. Check the starter motor housing conductivity. Be sure there is no conduction current between the cable terminal and the starter motor housing.

7. Check conductivity between the lead terminal and the brush. Replace them if necessary.

8. Measure the brush length. Its service limit is 5mm (.2 in.). Replace it if necessary. Check brush holder for conduction current. Replace if necessary.

9. Inspect bearing in front bracket for smooth rotation and for looseness when installed. Replace it if necessary. Inspect dust cover for wear or damage.

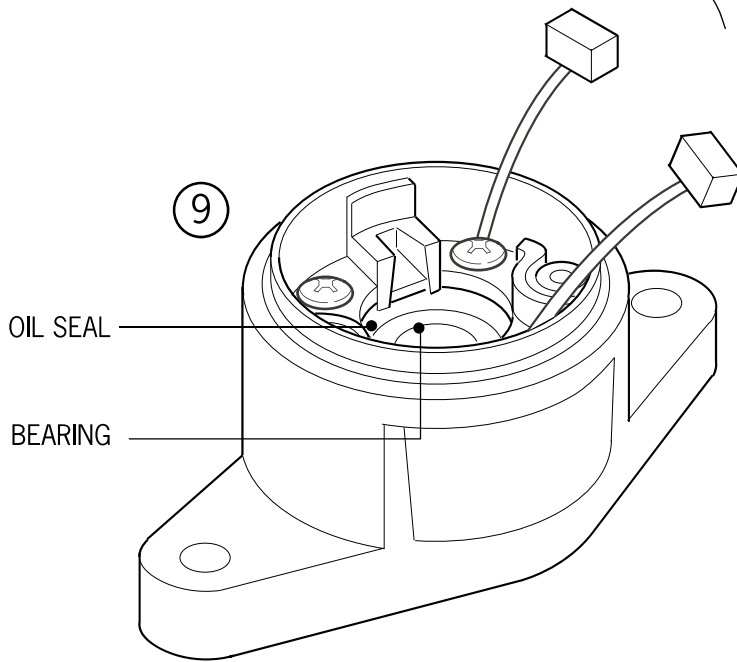
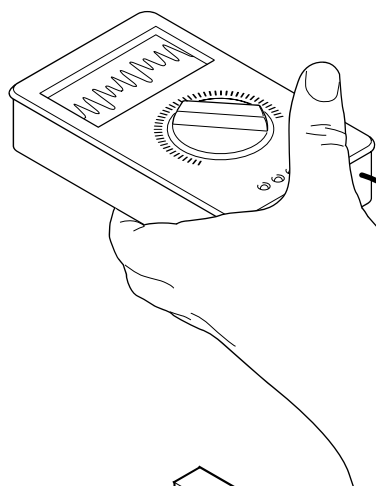
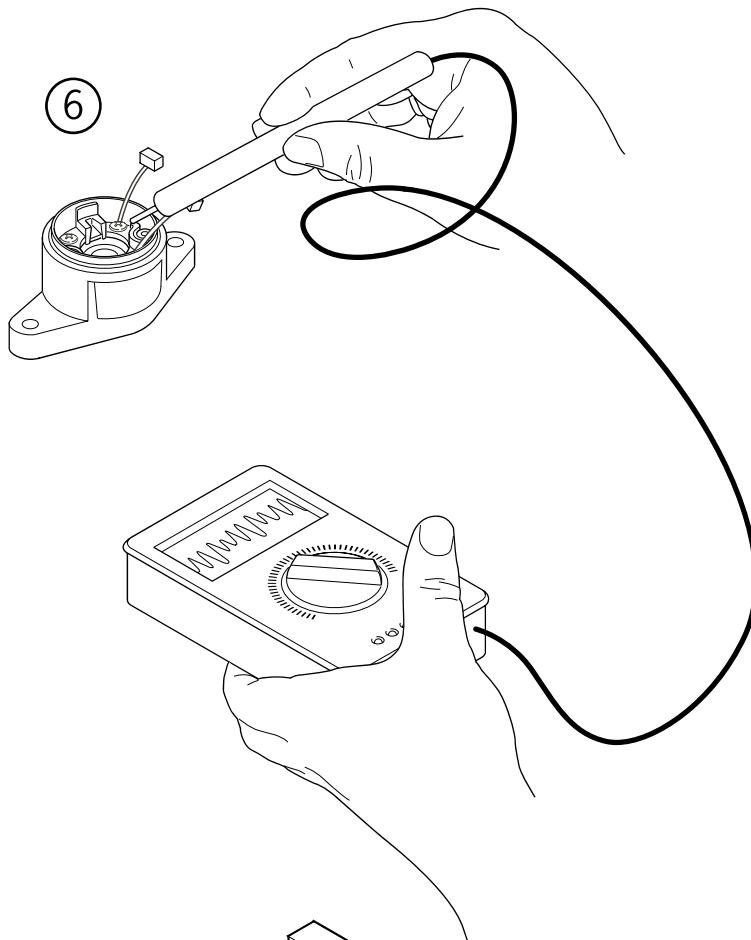

12. Starter System

10. Apply grease to the dust cover.

11. Install spring brush in its holder.

12. Apply a light film of grease to both ends of the sliding surfaces of the armature shaft.

13. Install armature in front bracket.

- Make sure the surfaces between the brush and the armature are not damaged.
- Be sure the dust cover lip is not damaged by the armature mount shaft.

14. Install a new o-ring in front bracket.

15. Engage motor housing with that of front bracket. Install two housing bolts.

- When engaging the housing with the front bracket, install the armature first, hold the armature shaft and then install the housing in case the armature is drawn out by the magnet.

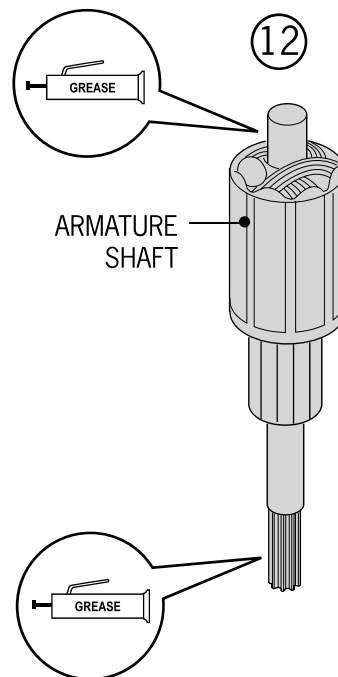
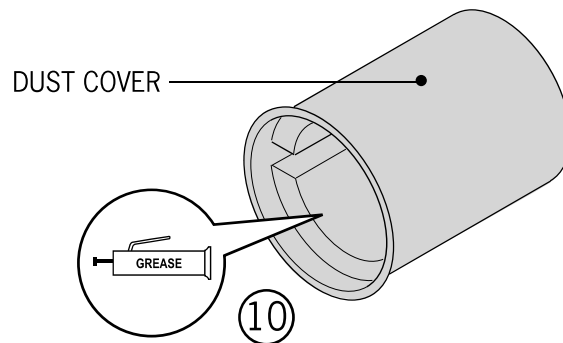

13

Starter Relay Inspection

1. Remove right side body panel.

2. With main switch in the "on" position, depress the starter button to check for a click, which indicates proper operation of relay. If starter button is depressed without a click, perform the following steps.

- Test starter relay voltage.
- Inspect starter relay ground return circuit.
- Inspect starter relay.

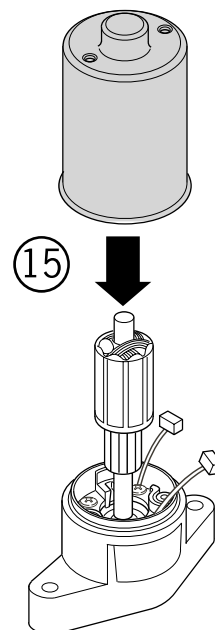
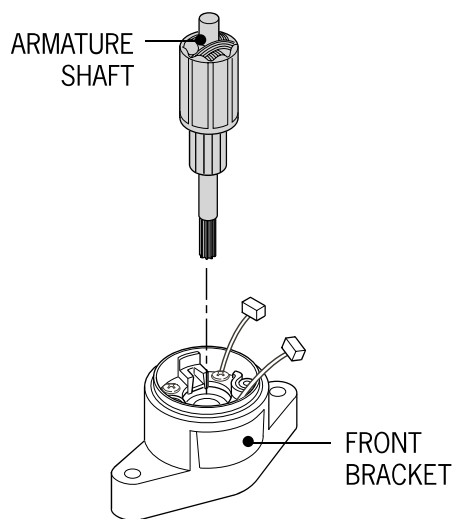

12. Starter System

3. To inspect starter relay voltage: Stand the scooter on its center stand, measure the voltage between the starter relay negative terminal (green/yellow cable) and the ground.

Turn the main switch to “on”, pull the brake levers and make sure the battery voltage is available at the relay (12 volts). If there is no battery voltage, inspect the brake switch electrical conductivity and wiring.

To inspect starter relay:

1. Remove the right side body panel.
2. Disconnect the starter relay unit coupler from the wire harness and remove it. Use ohm meter or continuity tester to check coil.
3. Connect the meter to terminals card D. This circuit should read closed. Use ohm meter or continuity tester C.
4. Check contactor.
5. Connect the meter to terminals A and B. This circuit should read open with terminals C and D disconnected and read closed with terminals C and D applied to 12 volt supply.

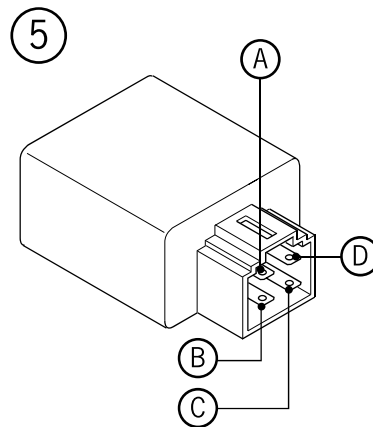

Starter Motor Installation

1. Apply grease to the starter motor o-ring and install the starter motor.
2. Install the two bolts.
3. Connect the starter motor terminals to the harness.

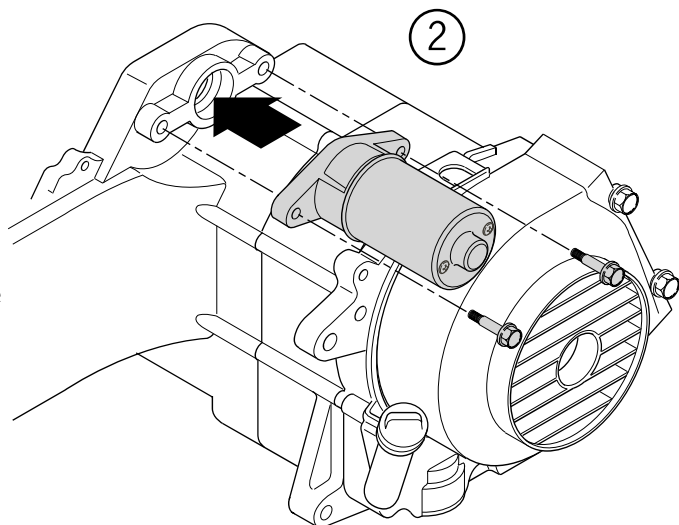

12. Starter System

3. Remove the four bolts and remove the cooling fan.

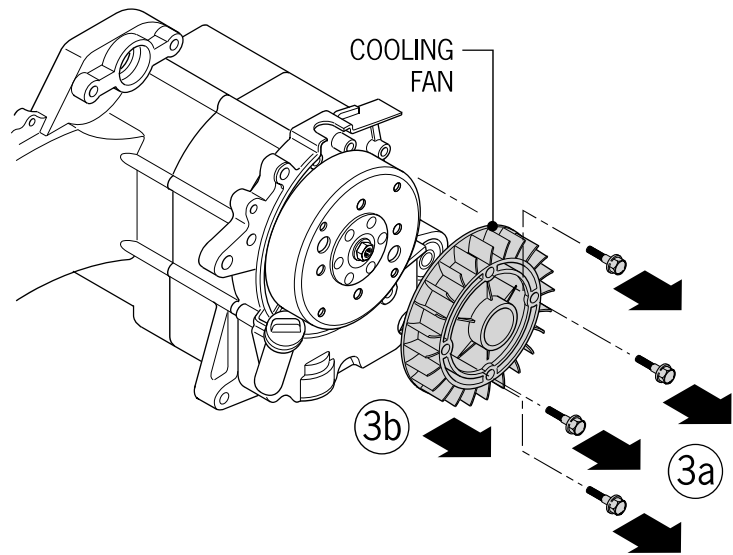

4. Use a universal solid wrench to secure the flywheel. Detach the fix nuts of the flywheel.

5. Use a spanner wrench hold flywheel while removing the retaining nut.

6. Use a flywheel puller to remove the flywheel.

7. Remove and save the key.

8. Detach the connecting wire of the magneto.

